

GENEBRE

2026 - 2027

Línea Industrial

Industrial Line

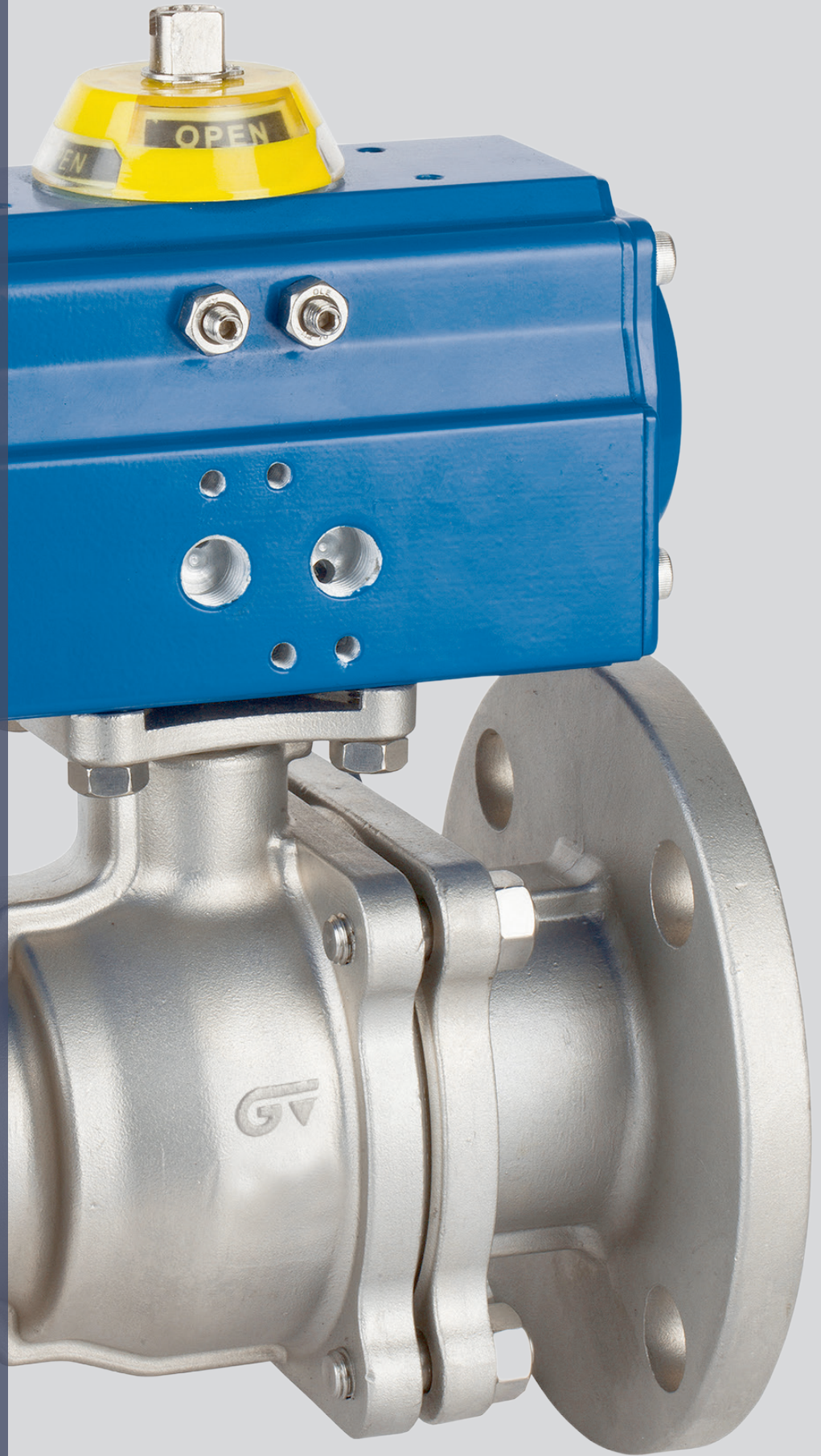

GENEBRE
PARTNER IN FLUID CONTROL SOLUTIONS

A low-angle photograph of a modern building's facade. The building features a prominent sign with a stylized 'G' logo in white and blue. The sky is a vibrant mix of orange, pink, and blue, suggesting a sunset or sunrise. The building's architecture includes dark metal panels and a blue-tinted section.

**Más de 45 años
impulsando tus
proyectos**

More than 45 years
supporting your projects

Tu **partner** en soluciones de control de fluidos

Your partner in fluid control solutions

Hay proyectos que empiezan con una idea. Y otros que empiezan con algo igual de importante: la tranquilidad de saber que no estás solo. Y en GENE BRE lo sabemos **desde 1981**.

A lo largo de más de 45 años, esta forma de trabajar nos ha convertido en un referente internacional en soluciones técnicas de alto valor para instalaciones profesionales de control de fluidos.

Diseñamos, producimos y trabajamos con un control integral del proceso, lo que nos permite garantizar fiabilidad y consistencia en cada solución: **desde el diseño hasta el producto final**. Y lo hacemos con una apuesta constante por la innovación, para seguir mejorando lo que ya funciona y anticiparnos a lo que viene.

Además, también fabricamos confianza. Porque te acompañamos proyecto a proyecto: desde nuestra atención al cliente cercana y personalizada, hasta el soporte técnico más especializado, a tu lado antes, durante, después y siempre que lo necesites.

Hoy, GENE BRE es el **partner de confianza** para profesionales de todo el mundo. Y este 45 aniversario también es una oportunidad para dar las gracias a quienes nos exigen cada día hacerlo mejor: clientes, instaladores, distribuidores y equipos técnicos.

*Some projects begin with an idea. Others begin with something just as important: the peace of mind that comes from knowing you're not alone. And at GENE BRE, we've known this **since 1981**.*

For over 45 years, this approach has made us an international leader in high-value technical solutions for professional fluid control systems.

*We design, manufacture and operate with comprehensive process control, enabling us to guarantee reliability and consistency in every solution: **from design to the final product**. And we do so with a constant commitment to innovation, to keep improving what already works and to anticipate what lies ahead.*

Furthermore, we also build trust. Because we are with you every step of the way: from our friendly, personalised customer service to the most specialised technical support, by your side before, during, after and whenever you need us.

*Today, GENE BRE is the **trusted partner** for professionals worldwide. And this 45th anniversary is also an opportunity to thank those who challenge us every day to do better: customers, installers, distributors and technical teams.*



45
YEARS
TOGETHER

¡Gracias por contar con nosotros!
Thank you for counting on us!

GENEBRE

PARTNER IN FLUID CONTROL SOLUTIONS

Más de 45 años
de evolución.

*More than 45 years
of evolution.*

Fundación
Foundation



1981

2001



Genebre Argentina

Genebre do Brasil



2005

2008



Holding
Genebre Group

Genebre Uruguay



2010

2012



Hobby Flower

Genwec Washroom
Equipment & Complements



2014

2023



Almacén logístico
automatizado
Automated logistics
warehouse

45 aniversario Genebre
45th anniversary of Genebre



2026

GENEBRE en cada solución

GENEBRE in every solution

Sabemos que no hay dos proyectos iguales. Por eso desarrollamos soluciones para cada sector: **hidrosanitaria, industrial, grifería doméstica, grifería pública y conectores.**

Como tu partner en soluciones de control de fluidos, acompañamos cada proceso de principio a fin, garantizando que cada sistema funcione con la máxima precisión. De este modo, optimizamos el rendimiento y el consumo energético en entornos domésticos, públicos e industriales.

Y así, ganan los proyectos, las personas y el planeta.

*We know no two projects are alike. That's why we develop solutions for each sector: **hydrosanitary, industrial, domestic taps, public taps and connectors.***

As your partner in fluid control solutions, we accompany each process from start to finish, guaranteeing maximum precision. This optimises performance and energy consumption in domestic, public and industrial environments.

This way, projects, people and the planet all benefit.

Línea industrial: la confianza de que nada se detiene

Industrial line: the confidence that nothing ever stops

Sabemos que detrás de cada instalación hay un compromiso con la eficiencia y la seguridad. Por eso, nuestras soluciones están pensadas para ir más allá de la resistencia técnica: buscamos darte la tranquilidad de que cada proceso funcionará con absoluta fiabilidad.

Diseñamos, producimos y comercializamos una amplia gama de soluciones para el control de fluidos, desde válvulas industriales en materiales como el acero inoxidable o la fundición nodular, hasta válvulas de la línea sanitaria y sistemas automatizados. Con más de 15 gamas, ofrecemos productos cuidados al detalle para garantizar la máxima seguridad en sectores tan diversos como el alimentario, el energético o el tratamiento de aguas.

Para que tu instalación responda siempre, pase lo que pase.

We know that behind every installation lies a commitment to efficiency and safety. That is why our solutions are designed to go beyond technical performance: we aim to give you the peace of mind that every process will operate with absolute reliability.

We design, manufacture and market a wide range of fluid control solutions, from industrial valves in materials such as stainless steel or ductile iron, to sanitary valves and automated systems. With over 15 product ranges, we offer meticulously crafted products to ensure maximum safety in sectors as diverse as food, energy and water treatment.

So that your installation always performs, no matter what.





Almacén inteligente, eficiencia en cada entrega

Smart warehouse, efficiency in every delivery

El servicio es el corazón de GENE BRE. Es lo que hace que un proyecto avance y funcione a la perfección.

Por eso contamos con:

- **Almacén inteligente y automatizado**
- **Stock permanente**
- **Entregas rápidas y eficientes**
- **Servicio click & collect**
- **Soporte técnico y servicio postventa**

Un buen producto se completa con un servicio a la altura. Y ese es el sello GENE BRE.

Service is the heart of GENE BRE. It is what drives a project forward and ensures it runs smoothly.

That is why we offer:

- *A smart, automated warehouse*
- *Permanent stock*
- *Fast and efficient deliveries*
- *A click & collect service*
- *Technical support and after-sales service*

A good product is truly complete with service that matches its quality. And that is the GENE BRE hallmark.

La calidad: **nuestra obsesión**

Diseñamos, producimos y controlamos el proceso de principio a fin para garantizar soluciones fiables, precisas y con el rendimiento que exige cada instalación.

No hay secretos en nuestra fórmula. Solo conocimiento técnico, experiencia internacional e innovación constante bajo estándares exigentes de calidad y sostenibilidad.

Quality: **our obsession**

We design, produce and control the process from start to finish to guarantee reliable, accurate solutions that deliver the performance required by each installation.

There are no secrets in our formula. Just technical knowledge, international experience and constant innovation under demanding quality and sustainability standards.



Así es como **garantizamos** más de 19 millones de piezas al año

This is how we guarantee over 19 million pieces per year

Control integral del proceso

Diseñamos nuestros propios productos, controlamos la producción y validamos cada fase.

Integral process control

We design our own products, supervise production and validate each phase, ensuring absolute consistency across the entire range.

Triple control de calidad

Cada pieza atraviesa tres filtros: centro productivo, centro de inspección técnica y control central en Barcelona.

Triple quality control

Because once is never enough. Each piece goes through three filters: production centre, technical inspection centre and central control in Barcelona.

Excelencia productiva demostrada

Logramos un estándar de calidad del **99,9935%** sin defectos, que equivale a una ratio de **65 dpm** (defectos por millón de piezas fabricadas).

Proven manufacturing excellence

*We achieve a **99.9935%** defect free standard, equivalent to **65 dpm** (defects per million), far below the industry average.*

Auditorías y certificaciones internacionales

Más de 10 auditorías anuales respaldan nuestros sistemas de gestión y producto según ISO 9001, ISO 14001, AENOR y LGAI Applus.

International audits and certifications

Our management and product systems are supported by more than 10 annual audits in accordance with ISO 9001, ISO 14001, AENOR and LGAI Applus.

Laboratorio propio de alta tecnología

Contamos con más de 30 tecnologías de ensayo y verificación. Validamos prestaciones y durabilidad sometiendo a cada componente a pruebas de estrés extremo.

High tech in house laboratory

We have more than 30 testing and verification technologies. We validate performance and durability by subjecting each component to extreme stress tests.

Presencia en comités técnicos

Somos miembros activos de cuatro comités europeos de normalización y de tres asociaciones sectoriales de referencia. Es decir: no solo seguimos las normas, participamos en su definición.

Presence in technical committees

We are active members of four European standardisation committees and three leading industry associations. In other words, we don't just follow the rules, we help to define them.

Especialización técnica

Un equipo de 21 especialistas dedicados exclusivamente a la calidad supervisa el flujo constante de nuestra producción.

Technical expertise

A team of 21 specialists dedicated exclusively to quality oversees the constant flow of our production.

Avalados por el mundo

Certificaciones y asociaciones internacionales

Trusted worldwide

International certifications and associations

Nuestro trabajo comienza mucho antes de que el producto llegue al mercado. Cada solución que entregamos ha superado un estricto proceso de verificación que nos distingue por su rigor y consistencia técnica.

Our work begins long before the product reaches the market. Every solution we deliver has undergone a rigorous verification process that sets us apart for our rigour and technical consistency.

A nuestra propia exigencia sumamos el aval de los mejores. Formamos parte activa de los organismos que marcan el rumbo de nuestra industria, como **AGRIVAL** (Asociación Española de Fabricantes de Grifería y Valvulería) y el **CEIR** (Asociación Europea de fabricantes de valvulería y grifería), además de colaborar con ECHA (la Agencia Europea de Sustancias y Mezclas Químicas). Asimismo, nuestro modelo de negocio, en línea con el **Club Excelencia en Gestión**, confirma un compromiso sólido y responsable con todos nuestros clientes.

*In addition to our own high standards, we have the endorsement of the best. We are an active member of the organisations that set the course for our industry, such as **AGRIVAL** (Spanish Association of Tap and Valve Manufacturers) and **CEIR** (European Association of Valve and Tap Manufacturers), as well as collaborating with ECHA (the European Chemicals Agency). Likewise, our business model, in line with the **Club for Excellence in Management**, confirms a solid and responsible commitment to all our customers.*



Excelencia en cada etapa del proceso

Excellence at every stage of the process

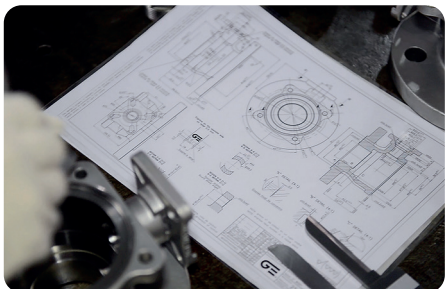

DISEÑO Y DESARROLLO PROPIOS
IN-HOUSE DESIGN AND DEVELOPMENT



VERIFICACIÓN TÉCNICA EN CADA ETAPA
TECHNICAL VERIFICATION AT EACH STEP



PRODUCCIÓN CON ESTÁNDARES INTERNACIONALES
PRODUCTION ALIGNED WITH INTERNATIONAL STANDARDS



PROCESOS AUDITADOS Y CERTIFICADOS
AUDITED AND CERTIFIED PROCESSES

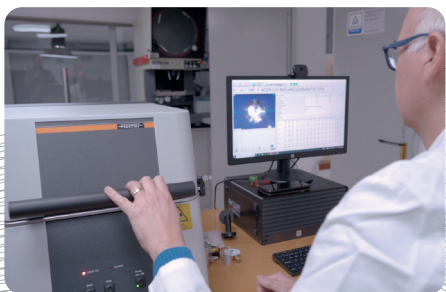

CONTROLES DE CALIDAD RIGUROSOS
RIGOROUS QUALITY CONTROL



ALMACÉN Y LOGÍSTICA AUTOMATIZADA
WAREHOUSE AND AUTOMATED LOGISTICS

Estamos donde están nuestros clientes: en todo el mundo

We are where our customers are: all over the world

La verdadera confianza se construye con un buen producto, pero también estando cerca, escuchando y acompañando a nuestros clientes.

True trust is built on a good product, but also by staying close to our customers, listening to them and supporting them.

GENEBRE es una marca internacional que nunca pierde de vista su origen local: con siete oficinas propias en tres continentes y presencia en más de 22 países con representación comercial, no solo exportamos soluciones; aportamos el conocimiento técnico que cada mercado necesita.

GENEBRE is an international brand that never loses sight of its local roots: with seven offices across three continents and a presence in over 22 countries through our sales representatives, we do more than just export solutions; we provide the technical expertise that every market requires.

Nos adaptamos a cada normativa asegurando que nuestra precisión llegue a cualquier lugar del mundo con la misma garantía.

We adapt to local regulations, ensuring that our precision reaches every corner of the globe with the same guarantee.

+140

Países de alcance
Countries covered



22

Países con representación comercial
Countries with sales offices

7

Oficinas en tres continentes
Offices on three continents

Proyectos con sello GENEBRE

GENEBRE-certified projects, where the standards are the highest

Nuestros productos están presentes en los proyectos más exigentes de todo el mundo. Desde la complejidad técnica de grandes infraestructuras, hasta la seguridad crítica de instalaciones industriales, comerciales o residenciales.

Nuestra capacidad de respuesta nos convierte en el partner de confianza para equipar entornos de referencia, donde la fiabilidad, la calidad y la precisión no son una opción, sino una necesidad.

Allí donde hay un reto de control de fluidos, hay una solución GENEBRE.

Our products are used in the most demanding projects around the world. From the technical complexity of major infrastructure projects to the critical safety requirements of industrial, commercial and residential facilities.

Our responsiveness makes us the trusted partner for equipping high-profile environments, where reliability, quality and precision are not an option, but a necessity.

Wherever there is a fluid control challenge, there is a GENEBRE solution.



Packaging y exposición a la altura de tu punto de venta

Packaging and display that live up to your point of sale

Queremos que gestionar nuestro producto sea tan sencillo como instalarlo.

Por eso, diseñamos cada etiqueta y embalaje para una identificación rápida y clara. Con los códigos QR integrados, tienes toda la información técnica siempre a mano.

Además, te apoyamos en tu espacio de venta con soluciones de exposición que atraen al cliente y refuerzan tu profesionalidad y la identidad de marca.

We want managing our product to be as simple as installing it.

That's why we design every label and package for quick and clear identification. With integrated QR codes, you always have all the technical information at your fingertips.

What's more, we support you on the shop floor with display solutions that attract customers and reinforce your professionalism and brand identity.



Tu partner de confianza, a un solo clic

Your trusted partner, just a click away

Estamos a tu lado también en el entorno digital. Herramientas diseñadas para que trabajes con mayor agilidad, accedas a nuestra información técnica y gestiones lo que necesites al instante.

Todo a un clic en nuestra web:

- **Área Exclusiva cliente:** Gestión de pedidos, consulta de ventajas personalizadas y comunicación directa con nosotros.
- **Catálogo:** Información completa de todos nuestros productos de cada línea de negocio.
- **Documentación:** Fichas técnicas, certificados, folletos y manuales de instalación.
- **Soporte multimedia:** Vídeos de producto, imágenes, formaciones y área de descargas.
- **Actualidad:** Noticias del sector y novedades de nuestra marca.

We're here to support you in the digital world too. Tools designed to help you work more efficiently, access our technical information and manage whatever you need in an instant.

All just a click away on our website:

- **Exclusive Customer Area:** Order management, viewing personalised benefits and direct communication with us.
- **Catalogue:** Comprehensive information on all our products across every business line.
- **Documentation:** Technical data sheets, certificates, brochures and installation manuals.
- **Multimedia support:** Product videos, images, training resources and a downloads section.
- **News:** Industry news and updates from our brand.

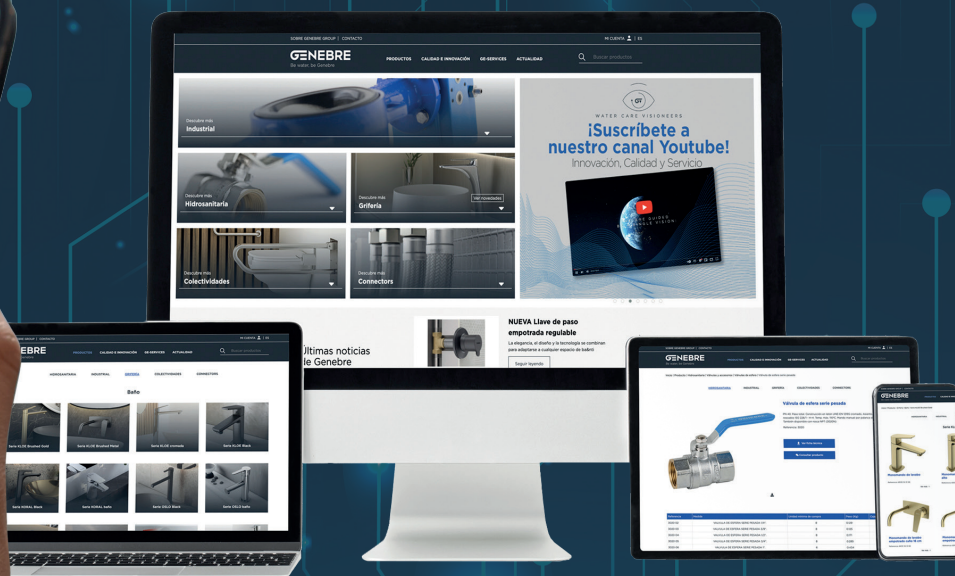
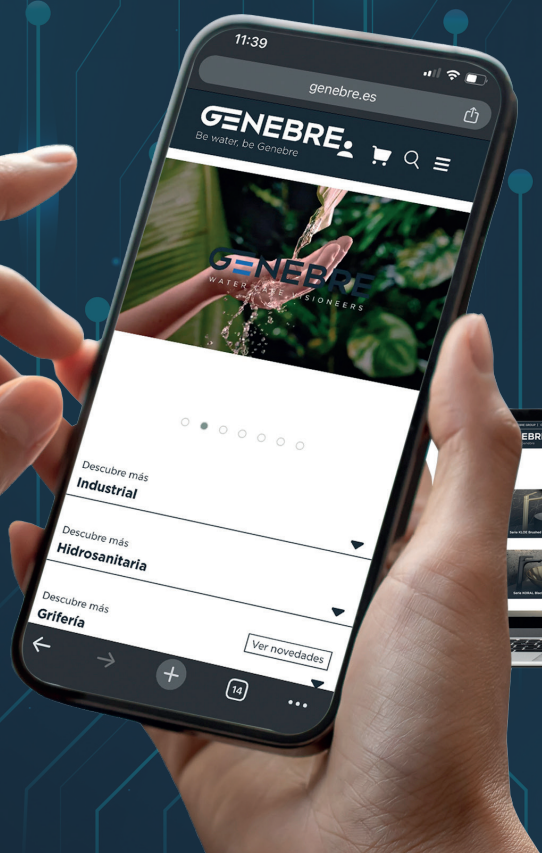



Sigamos hablando
Let's keep talking

ESPAÑA / SPAIN

comercial@genebre.es
www.genebre.es
Tel: 93 298 80 01 - Fax: 93 298 80 06

Tel. Centralita / Central telephone number:

+34 93 298 80 00

Administración / Administration:

+34 93 298 80 02

Fax: +34 93 298 80 07

Servicio de Atención Técnica al Cliente /

Technical Support telephone number:

+34 902 504 203

CORREO / MAILING ADDRESS

Edificio Genebre
Av. Joan Carles I, 46-48
Distrito económico de L'Hospitalet
L'Hospitalet de Llobregat 08908
Barcelona (Spain)

**HORARIO COMERCIAL /
COMMERCIAL TIMETABLE:**

8.30 h. - 13.30 h. | 15.00 h. - 18.00 h.

Viernes / Friday 8:00 h. - 16:00 h.



genebre.es

INTERNACIONAL / INTERNATIONAL

exportacion@genebre.es
www.genebre.com

Europa / Europe: +34 93 298 80 15

Europa Este / Eastern Europe:

+34 93 298 80 19

América Latina / Latin America:

+34 93 298 80 17

América del Norte / North America:

+34 93 298 80 17 - Fax: +34 93 298 80 08

OFICINAS / OFFICES

- **Genebre Headquarters:** Barcelona, Spain
- Genebre do Brasil - São Paulo (Brazil)
genebre.com.br
- Genebre Argentina - Buenos Aires (Argentina)
genebre.com.ar
- Ningbo (China)

Síguenos / Follow us



Genebre S.A



@genebre_es



@genebre_es



Genebre S.A



@genebre_es



Video corporativo
Corporate video

GENEBRE

45 YEARS
TOGETHER

**Impulsando tus proyectos.
Y seguimos.**

Gracias por formar parte de nuestra historia.

Bringing your projects to life.
Thank you for being part of our story

VÁLVULAS VALVES 01



Válvulas extremos roscados / Threaded ends valves	p. 21
Válvulas extremos soldables / Welded ends valves	p. 28
Válvulas mariposa / Butterfly valves	p. 29
Válvulas para instalaciones fijas contra incendios / Valves for fire protection systems	p. 34
Válvulas esfera tipo Wafer / Wafer type ball valves	p. 36
Válvulas de regulación / Regulation valves	p. 38
Válvulas de seguridad / Safety valves	p. 44
Válvulas reductoras de presión / Pressure reducing valves	p. 46
Purgadores para vapor / Steam trap	p. 47
Válvulas de retención / Check valves	p. 52
Filtros / Strainers	p. 58
Válvulas extremos bridados / Flange ends valves	p. 60
Manguitos elásticos y de expansión / Rubber expansion joints	p. 63
Controladores de flujo / Liquid flow switches	p. 66
Válvulas de flotador / Floating valves	p. 66
Válvulas con esfera caracterizada / Variable ball valves	p. 68
Extensor para válvula manual / Extension for manual valves	p. 70

LÍNEA SANITARIA SANITARY LINE 02



Válvulas de esfera / Ball valves	p. 75
Válvulas toma muestra / Sampling valves	p. 76
Válvulas de retención / Check valves	p. 76
Válvulas diafragma / Diaphragm valves	p. 75
Válvulas mariposa / Butterfly valves	p. 79
Accesorios línea sanitaria / Sanitary line accessories	p. 80
Automatización / Automation	p. 83

AUTOMATIZACIÓN Y CONTROL AUTOMATION & CONTROL 03



Válvulas neumáticas / Pneumatic valves	p. 93
Actuador neumático / Pneumatic actuators	p. 94
Electroválvulas / Solenoid valves	p. 114
Posicionadores / Positioners	p. 116
Reductores / Gear operators	p. 117
Microrruptores final de carrera / Limit switch box	p. 118
Extensor para válvula automatizada - actuador neumático / Extension for automated valve - pneumatic actuator	p. 121
Actuador eléctrico monofásico / Single-phase electric actuators	p. 124-135
Actuador eléctrico trifásico / Three-phase electric actuators	p. 127-135
Extensor para válvula automatizada - actuador eléctrico / Extension for automated valve - electric actuator	p. 137

ÍNDICE

INDEX

FITTINGS INOXIDABLES

04

STAINLESS STEEL
FITTINGS



Fittings inoxidables / Stainless steel fittings	p. 140
Racord Camlock AISI 316 / Camlock fitting AISI 316	p. 145
Rácores con bicono en acero inoxidable 316 / 316 stainless steel compression fittings	p. 147

INSTRUMENTACIÓN INDUSTRIAL

05

INDUSTRIAL
INSTRUMENTATION



Manómetros / Pressure gauges	p. 155
Termómetros / Thermometers	p. 156
Sondas / Probes	p. 158
Convertidores / Indicators	p. 159
Reguladores / Regulators	p. 159
Transmisores de presión / Pressure transmitters	p. 159

RECAMBIOS PARA VÁLVULAS DE ESFERA

SPARE PARTS FOR BALL VALVES

p. 162

ÍNDICE POR ARTÍCULOS

ARTICLE INDEX

p. 166

CONDICIONES GENERALES DE VENTA

GENERAL SALES CONDITIONS

01.





VÁLVULAS INDUSTRIALES

Industrial Valves

Selección completa de válvulas y accesorios para el control de fluidos, en sus diferentes tipologías y de diferentes materiales como acero inoxidable y acero al carbono.

A complete selection of valves and accessories for fluid control, using various materials such as stainless steel, carbon steel, etc.

Válvulas extremos roscados / Threaded ends valves	p. 21
Válvulas extremos soldables / Welded ends valves	p. 28
Válvulas mariposa / Butterfly valves	p. 29
Válvulas para instalaciones fijas contra incendios / Valves for fire protection systems	p. 34
Válvulas esfera tipo Wafer / Wafer type ball valves	p. 36
Válvulas de regulación / Regulation valves	p. 38
Válvulas de seguridad / Safety valves	p. 44
Válvulas reductoras de presión / Pressure reducing valves	p. 46
Purgadores por vapor / Steam trap	p. 47
Válvulas de retención / Check valves	p. 52
Filtros / Strainers	p. 58
Válvulas extremos bridados / Flange ends valves	p. 60
Manguitos elásticos y de expansión / Rubber expansion joints	p. 63
Controladores de flujo / Liquid flow switches	p. 66
Válvulas de flotador / Floating valves	p. 66
Válvulas con esfera caracterizada / Variable ball valves	p. 68
Extensor para válvula manual / Extension for manual valves	p. 70

Válvulas industriales

Industrial valves

Factores de conversión

Conversion factors

PRESIÓN PRESSURE			
	Kg / cm ²	PSI	Bar
Kg / cm ²	1	14,22	0,980665
PSI	0,070307	1	0,06895
Bar	1,0197	14,5038	1

TEMPERATURA TEMPERATURE		
	°C	°F
°C	1	32+(1.8 x °C)
°F	°F - 32 / 1.8	1

Expresión de la pérdida de carga

Lost charge expression

Q = Caudal circulante (en m³/h)
Medium flow (in m³/h)

Kv = Coeficiente de caudal o de forma de cada válvula
Valve flow or shape coefficient

Δp = Pérdida de carga (en bar)
Head losses (in bar)

ρ = Masa específica (en Kg/m³)
Medium density (in Kg/m³)

$$Q = Kv \sqrt{\frac{\Delta p}{\rho}}$$

Cálculo de velocidad

Calculation of the speed

V = Velocidad de circulación (en m/s)
Circulation speed (in m/s)

Q = Caudal (en m³/h)
Flow (in m³/h)

D = Diámetro de paso (en mm)
Bore diameter (in mm)

$$V = 353,7 \frac{Q}{D^2}$$

Ref.2001



Válvula esfera paso reducido 1 pieza

Const.: AISI 316 pulido. FV. Asientos PTFE. Extremos: Rosca ISO 7-1 (EN 10226-1). PN 63 Temp. -25°C +180°C. Mando manual por palanca.

1 pc reduced bore ball valve

Constr.: polished AISI 316 Seats PTFE. Threaded. Ends ISO 7-1 (EN 10226-1). PN 63 Temp. -25°C +180°C. Manually operated by handle

MED.	P	A	L	M
1/4"	5	31	40	65
3/8"	7	36	45	85
1/2"	9	41	57	95



Información técnica
Technical information

CÓDIGO CODE	MEDIDA SIZE	PESO WEIGHT	CAJA / BOX CARTON	P.V.P. € PRICE €
-------------	-------------	-------------	-------------------	------------------

2001 02	1/4"	0.07	40-320	19,69
2001 03	3/8"	0.112	20-160	19,72
2001 04	1/2"	0.188	15-120	23,86

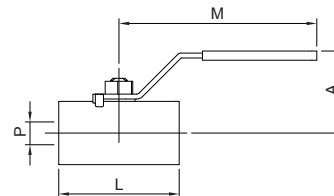

Ref.2002 - 2004



Válvula esfera paso reducido 1 pieza

Art. 2002 rosca NPT ASME B1.20.1
Art. 2004 rosca ISO 7-1 (EN 10226-1).
Const. acero inox CF8M (316) Microfusión. Asientos: PTFE PN 63 temp. -25°C +180°C. Mando manual por palanca. Con sistema de bloqueo.

1 pc reduced bore ball valve NPT thread

Art. 2002 NPT thread ASME B1.20.1
Art. 2004 ISO 7-1 (EN 10226-1) thread
Const. stainless steel CF8M (316). Investment. Casting. Seats: PTFE PN 63 temp. -25°C + 180°C. Manually operated by handle. With locking system.

MED.	P	A	L	M
1/4"	4,6	32	39	60
3/8"	6,8	36	44	80
1/2"	9,2	42	56	87
3/4"	12,5	45	59	87
1"	15	50	69	105
1 1/4"	20	54	77	105
1 1/2"	25	70	81	125
2"	32	78	97	140



Información técnica
Technical information

2002 02	1/4"	0.067	40-320	12,51
2002 03	3/8"	0.103	20-160	12,61
2002 04	1/2"	0.177	15-120	14,89
2002 05	3/4"	0.251	10-80	18,51
2002 06	1"	0.41	5-40	24,02
2002 07	1 1/4"	0.669	4-32	36,31
2002 08	1 1/2"	0.804	2-16	46,15
2002 09	2"	1.248	1-12	70,43

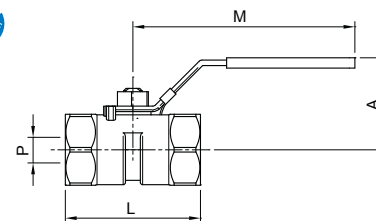

Ref.2005



Válvula esfera paso reducido 1 pieza M-H

Const: AISI 316 pulido - asientos PTFE
Extremos rosca M - H ISO 7-1 (EN 10226-1). PN 63.
Temp. -25°C + 180°C. Mando manual.

1 pc reduced bore ball valve M-F

Const. polished stainless steel AISI 316. M-F threaded ends. ISO 7-1 (EN 10226-1) PN 63. Seats: PTFE. Temp. -25°C +180°C manually operated.

MED.	P	A	L	M
1/4"	8	26	40	22
3/8"	8	26	40	22
1/2"	10	28	46	22
3/4"	12	34	54	22
1"	15	34	65	22



Información técnica
Technical information

2005 02	1/4"	0.076	20-280	15,85
2005 03	3/8"	0.082	20-280	17,14
2005 04	1/2"	0.116	20-160	19,39
2005 05	3/4"	0.195	15-180	23,81
2005 06	1"	0.329	6-72	35,26

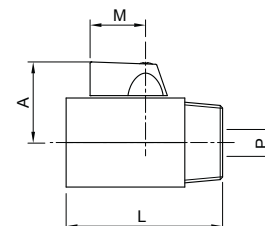

Ref.2006



Válvula esfera paso reducido 1 pieza H-H

Const: AISI 316 pulido - Asientos PTFE
Extremos rosca ISO 7-1 (EN 10226-1). PN 63
PN-63. Temp. -25°C +180°C. Mando manual.

1 pc reduced bore ball valve F-F

Const. polished stainless steel AISI 316.
Seats: PTFE. F-F ISO 7-1 (EN 10226-1) threaded ends. PN 63
Temp. -25°C +180°C. Manually operated.

MED.	P	A	L	M
1/4"	8	26	40	22
3/8"	8	26	40	22
1/2"	10	28	46	22
3/4"	12	34	54	22
1"	15	34	65	22



Información técnica
Technical information

2006 02	1/4"	0.092	20-240	15,24
2006 03	3/8"	0.085	20-260	16,47
2006 04	1/2"	0.115	15-195	18,10
2006 05	3/4"	0.204	15-180	22,91
2006 06	1"	0.34	6-72	31,33

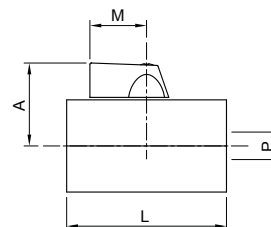

Ref.2007 - 2007N



Válvula de esfera paso total Alta Presión

Rosca BSP, también disponible con rosca NPT (2007N).
Const.: acero al carbono ASTM A105.
Esfera y eje inoxidable 304. Asientos PEEK.
Serie 1500 (255 bar) - Temp. -30°C +250°C.

High Pressure full bore ball valve

BSP thread, also available with NPT thread (2007N).
Const. carbon steel ASTM A105.
Ball and stem: stainless steel 304. Seats: PEEK.
Class 1500 (255 bar) - Temp. -30°C +250°C.

MED.	A	M	L
1/4"	70	155	65
3/8"	70	155	65
1/2"	74	155	76
3/4"	87	180	91
1"	92	180	100



Información técnica
Technical information

CÓDIGO CODE	MEDIDA SIZE	PESO WEIGHT	CAJA / BOX CARTON	P.V.P. € PRICE €
-------------	-------------	-------------	-------------------	------------------

2007 02	1/4"	0.636	6-30	68,58
2007 03	3/8"	0.617	6-30	68,58
2007 04	1/2"	0.905	6-18	81,92
2007 05	3/4"	1.551	4-8	121,98
2007 06	1"	2.221	4-8	152,21

Precios rosca NPT a consultar / NPT thread prices on request

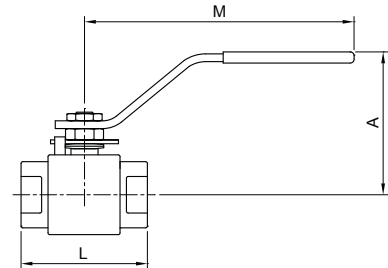

Ref.2008



Válvula esfera paso reducido 2 piezas

Const.: acero inox. CF8M (316) microfundición. Juntas y asientos: PTFE+FV extremos: rosca ISO 7-1 (EN 10226-1). PN 140 temp. -25°C +180°C. Mando manual por palanca con sistema de bloqueo.

2 pcs reduced bore ball valve

Const: stainless steel CF8M (316). Investment casting. Seats and seals: PTFE + GF ends: threaded ends ISO 7-1 (EN 10226-1). PN 140. Temp -25°C +180°C. Manually operated by handle with locking system.

MED.	P	A	L	M
1/4"	9,5	42	54	105
3/8"	9,5	42	54	105
1/2"	13	46	61,5	105
3/4"	17,5	53	72	147
1"	22	58	84,5	147
1 1/4"	25,4	68	92	168
1 1/2"	31,7	72	103	193
2"	38,1	78	118	193



Información técnica
Technical information

2008 02	1/4"	0.216	12-72	27,01
2008 03	3/8"	0.2	12-72	27,01
2008 04	1/2"	0.293	12-72	28,14
2008 05	3/4"	0.56	5-30	41,63
2008 06	1"	0.809	5-30	58,40
2008 07	1 1/4"	1.069	2-12	62,80
2008 08	1 1/2"	1.673	6-12	88,12
2008 09	2"	2.56	4-8	130,50

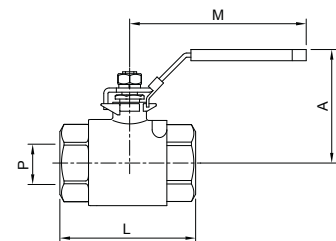

Ref.2009



Válvula esfera paso total 2 piezas H-H

Const.: acero inox. CF8M (316) microfundición. Extremos H-H rosca ISO 7-1 (EN 10226-1). Asientos PTFE + 15%. FV tórica eje viton. PN 63. Temp. -25°C +180°C. Mando manual por palomilla.

2 pcs full bore ball valve F-F

Const: stainless steel CF8M (316). Investment casting. Threaded F-F ISO 7-1 (EN 10226-1). Seats: PTFE + 15% GF. O'ring stem: viton. PN 63. Temp. -25°C +180°C. Butterfly handle.

MED.	A	L	M
1/4"	42	50	50
3/8"	42	50	50
1/2"	44,5	55	50
3/4"	57	70	60
1"	60	83	60



Información técnica
Technical information

2009 02	1/4"	0.185	15-90	18,63
2009 03	3/8"	0.174	15-180	18,63
2009 04	1/2"	0.217	10-60	20,10
2009 05	3/4"	0.425	6-36	26,69
2009 06	1"	0.593	4-48	35,79

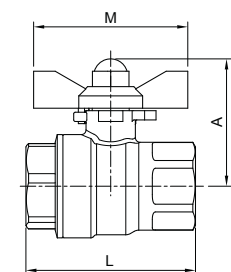

Ref.2010



Válvula esfera paso total 2 piezas M-H

Const.: acero inox. CF8M (316) microfundición. Extremos M-H rosca ISO 7-1 (EN 10226-1). Asientos PTFE + 15%. FV tórica eje vitón. PN 63. Temp. -25°C +180°C. Mando manual por palomilla.

2 pcs full bore ball valve M-F

Const: stainless steel CF8M (316). Investment casting. Threaded M-F ISO 7-1 (EN 10226-1). Seats: PTFE + 15% GF. O'ring stem: viton. PN 63. Temp. -25°C +180°C. Butterfly handle.

MED.	A	L	M
1/4"	42	56	50
3/8"	42	56	50
1/2"	44,5	63	50
3/4"	57	80	60
1"	60	91	60



Información técnica
Technical information

2010 02	1/4"	0.182	15-120	18,88
2010 03	3/8"	0.179	10-120	18,88
2010 04	1/2"	0.226	8-64	20,67
2010 05	3/4"	0.442	6-36	28,05
2010 06	1"	0.616	4-48	37,59

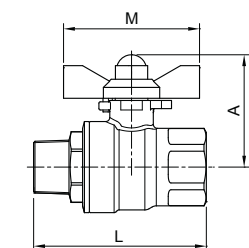

Ref.2011



Válvula esfera paso total 2 piezas

Const.: acero inox. CF8 (304) microfundición. Extremos: rosca ISO 7-1 (EN 10226-1). Asientos: PTFE + 15% FV. Tórica eje Viton. PN 40, Temp: -25°C +180°C. Mando manual por palanca con sistema de bloqueo (NC).

2 pcs full bore ball valve

Const. stainless steel CF8 (304) investment casting. Threaded ends ISO 7-1 (EN 10226-1). Seats: PTFE + 15% GF. O'ring Stem: viton. PN 40. Temp: -25°C +180°C. Manually operated by handle with locking system (NC).

MED.	A	L	M
1/2"	50	48	104
3/4"	60	59	122
1"	63	70	122



Información técnica
Technical information

CÓDIGO CODE	MEDIDA SIZE	PESO WEIGHT	CAJA / BOX CARTON	P.V.P. € PRICE €
-------------	-------------	-------------	-------------------	------------------

2011 04	1/2"	0.164	10-120	12,85
2011 05	3/4"	0.291	6-72	17,68
2011 06	1"	0.446	4-48	23,99

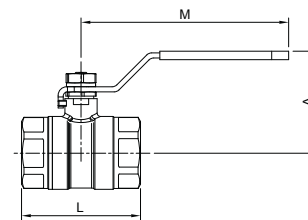

Ref.2013



Válvula esfera paso total 2 piezas M-H

Construcción: acero inox. CF8M (316) microfundición. Extremos: M-H rosca ISO 7-1 (EN 10226-1). Asientos: PTFE + 15% FV. Tórica eje Viton. PN 63, Temperatura: -25°C +180°C. Mando manual por palanca con sistema de bloqueo.

2 pcs full bore ball valve M-F

Construction: stainless steel CF8M (316) investment casting. Threaded ends M-F ISO 7-1 (EN 10226-1). Seats: PTFE + 15% GF. O'ring stem: viton. PN 63. Temperature: -25°C +180°C. Manually operated by handle with locking system.

MED.	A	L	M
1/4"	50	56	104
3/8"	50	56	104
1/2"	51	63	104
3/4"	62	80	122
1"	65	91	122
1 1/4"	82	106	180
1 1/2"	88	116	180
2"	106	135	220



Información técnica
Technical information

2013 02	1/4"	0.199	12-144	19,19
2013 03	3/8"	0.196	12-144	19,19
2013 04	1/2"	0.242	10-90	20,69
2013 05	3/4"	0.452	6-36	27,47
2013 06	1"	0.62	4-24	36,85
2013 07	1 1/4"	1.14	2-12	54,47
2013 08	1 1/2"	1.535	6-12	77,57
2013 09	2"	2.745	3-6	123,87

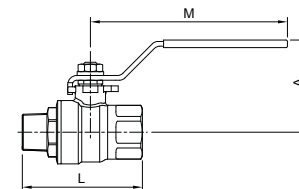

Ref.2014 - 2014N



Válvula esfera paso total 2 piezas

Rosca BSP, también disponible con rosca NPT (2014N). Const. acero inox. CF8M (316) microfundición. Extremos: rosca ISO 7-1 (EN 10226-1). Juntas y asiento: PTFE + 15% FV tórica eje vitón PN 63, Temp: -25°C + 180°C. Mando manual por palanca con sistema de bloqueo.

2 pcs full bore ball valve

BSP thread, also available with NPT thread (2014N). Const. stainless steel. CF8M (316) investment casting. Threaded ends ISO 7-1 (EN 10226-1). Seats and seals: PTFE + 15% GF. O'ring stem: viton. PN 63. Temp. -25°C +180°C. Manually operated by handle with locking system.

MED.	A	M	L
1/4"	50	104	50
3/8"	50	104	50
1/2"	51,5	104	55
3/4"	62	122	70
1"	65	122	83
1 1/4"	82	180	91
1 1/2"	88	180	103
2"	106	220	120
2 1/2"	119	220	152
3"	135	275	172



Información técnica
Technical information



2014 02	1/4"	0.202	12-108	18,28
2014 03	3/8"	0.191	12-108	18,28
2014 04	1/2"	0.234	10-90	19,25
2014 05	3/4"	0.438	6-54	25,56
2014 06	1"	0.601	4-36	34,24
2014 07	1 1/4"	1.066	8-16	51,75
2014 08	1 1/2"	1.54	6-12	82,50
2014 09	2"	2.735	3-6	117,66
2014 10	2 1/2"	4.786	2-4	231,91
2014 11	3"	7.434	1-2	366,82

Precios rosca NPT a consultar / NPT thread prices on request

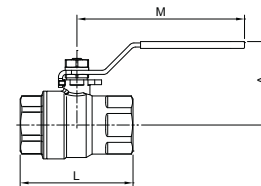

Ref.2015 - 2015N



Válvula esfera paso total 2 piezas

Rosca BSP, también disponible con rosca NPT (2015N). Const.: AISI 316 - juntas y asientos PTFE+FV extremos: rosca ISO 7-1 (EN 10226-1) tórica eje: vitón. PN 63. Temp. -25°C +180°C. Mando manual por palanca. Montaje directo s/ISO 5211 con sistema de bloqueo.

2 pcs full bore ball valve

BSP thread, also available with NPT thread (2015N). Const. AISI 316 seats and seals PTFE + GF threaded ends ISO 7-1 (EN 10226-1). O'ring stem: viton. PN 63. Temp. -25°C +180°C. Manually operated by handle. Direct assembling ISO 5211 with locking system.

MED.	A	M	L	ISO 5211
1/4"	62	112	50	F-03
3/8"	62	112	50	F-03
1/2"	63	112	55	F-03/F-04
3/4"	70	138	70	F-04/F-05
1"	70	160	83	F-04/F-05
1 1/4"	88	160	91	F-05/F-07
1 1/2"	94	205	103	F-05/F-07
2"	100	205	103	F-05/F-07



Información técnica
Technical information

2015 02	1/4"	0.3	8-96	23,69
2015 03	3/8"	0.288	8-96	23,69
2015 04	1/2"	0.327	6-54	25,12
2015 05	3/4"	0.571	3-36	38,09
2015 06	1"	0.731	2-24	48,27
2015 07	1 1/4"	1.359	8-16	69,52
2015 08	1 1/2"	1.9	6-12	90,07
2015 09	2"	2.847	3-6	139,71

Precios rosca NPT a consultar / NPT thread prices on request

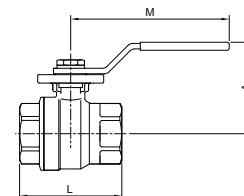

Ref.2016



Válvula Esfera 2 piezas H-M Camlock

Const.: acero inox. CF8M (316) microfusión. Extremos: Hembra rosca ISO 7-1 (EN 10226-1). Macho Camlock. Asientos:PTFE + 15% FV. Tórica eje Viton. PN10. Temp: -25°C +180°C. Mando manual por palanca con sistema de bloqueo.

2 piezas Ball valve. F-M Camlock

Const. stainless steel CF8M (316) investment casting. Female Threaded ends ISO 7-1 (EN 10226-1), Camlock Male. Seats: PTFE + 15% GF. O'ring Stem: viton. PN10. Temp: -25°C +180°C. Manually operated by handle with locking system

MED.	D	A	L	M
1/2"	24	51,5	82	104
3/4"	32	62	96	122
1"	36,5	65	116	122
1 1/4"	45,5	82	131	180
1 1/2"	53,5	88	141	180
2"	63	106	164	220
2 1/2"	75,8	119	202	220
3"	91,5	135	223	275



Información técnica
Technical information

CÓDIGO CODE	MEDIDA SIZE	PESO WEIGHT	CAJA / BOX CARTON	P.V.P. € PRICE €
2016 04	1/2"	0.304	6-48	29,74
2016 05	3/4"	0.545	4-32	40,26
2016 06	1"	0.756	2-18	54,99
2016 07	1 1/4"	1.355	6-12	88,86
2016 08	1 1/2"	1.922	1	122,67
2016 09	2"	3.161	2-4	194,57
2016 10	2 1/2"	5.431	1-2	330,04
2016 11	3"	8.347	1-2	485,89

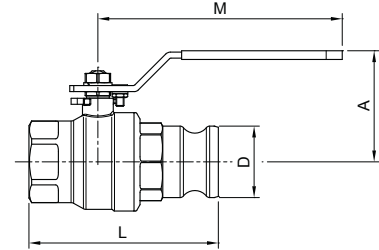

Ref. 2025 - 2025N



Válvula esfera paso total 3 piezas

Rosca BSP, también disponible con rosca NPT (2025N). Const.: acero inox. CF8M (316) microfusión rosca ISO 7-1 (EN 10226-1). Juntas y asientos PTFE + 15% FV tórica eje: vitón. PN - 63. Temp. -25°C + 180°C. Montaje directo s/ ISO 5211 con sistema de bloqueo.

3 pcs full bore ball valve

BSP thread, also available with NPT thread (2025N). Const.: stainless steel CF8M (316) investment casting thread ISO 7-1 (EN 10226-1). Seats and seats: PTFE +15% GF o'ring stem: viton PN-63. Temp. -25°C +180°C. Direct assembling ISO 5211 with locking system.

MED.	P	L	A	M	ISO 5211
1/4"	11	47,6	60	112	F-03
3/8"	12,7	47,6	60	112	F-03
1/2"	15	56	60	112	F-03/F-04
3/4"	20	73	70	138	F-04/F-05
1"	25	82	70	138	F-04/F-05
1 1/4"	32	91	88	160	F-05/F-07
1 1/2"	40	104	94	205	F-05/F-07
2"	50	120	100	205	F-05/F-07
2 1/2"	65	155	150	325	F-07/F-10
3"	80	182	165	325	F-07/F-10
4"	100	220	175	325	F-07/F-10



Información técnica
Technical information

2025 02	1/4"	0.391	8-64	23,80
2025 03	3/8"	0.373	8-64	23,80
2025 04	1/2"	0.428	6-54	26,10
2025 05	3/4"	0.827	3-27	40,89
2025 06	1"	1.027	2-20	49,67
2025 07	1 1/4"	1.855	8-8	79,81
2025 08	1 1/2"	2.513	4-8	103,49
2025 09	2"	3.573	2-6	147,39
2025 10	2 1/2"	8.856	2	365,36
2025 11	3"	12.838	1	514,62
2025 12	4"	19.746	1	862,93

Precios rosca NPT a consultar / NPT thread prices on request

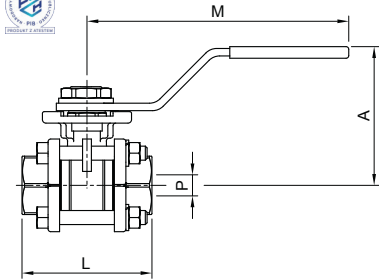

Ref.2025C



Válvula esfera paso total 3 piezas - Grafito

Const.: acero inox. CF8M (316) microfusión rosca ISO 7-1 (EN 10226-1). Juntas y asientos PTFE + 25% Grafito, tórica eje: vitón. PN 63. Temp. -25°C + 250°C. Montaje directo s/ISO 5211 con sistema de bloqueo.

3 pcs full bore ball valve - Graphite

Const.: stainless steel CF8M (316) investment casting thread ISO 7-1 (EN 10226-1). Seats and seats: PTFE +25% Graphite, o'ring stem: viton PN 63. Temp. -25°C +250°C. Direct assembling ISO 5211 with locking system.

MED.	P	L	A	M	ISO 5211
1/4"	11	47,6	60	112	F-03
3/8"	12,7	47,6	60	112	F-03
1/2"	15	56	60	112	F-03/F-04
3/4"	20	73	70	138	F-04/F-05
1"	25	82	70	138	F-04/F-05
1 1/4"	32	91	88	160	F-05/F-07
1 1/2"	40	104	94	205	F-05/F-07
2"	50	120	100	205	F-05/F-07
2 1/2"	65	155	150	325	F-07/F-10
3"	80	182	165	325	F-07/F-10
4"	100	220	175	325	F-07/F-10



Información técnica
Technical information

2025C 02	1/4"	0.39	-	28,71
2025C 03	3/8"	0.372	8-64	-
2025C 04	1/2"	0.426	6-54	30,25
2025C 05	3/4"	0.832	3-27	47,27
2025C 06	1"	1.032	2-20	57,01
2025C 07	1 1/4"	1.86	8-8	95,44
2025C 08	1 1/2"	2.505	4-8	122,45
2025C 09	2"	3.581	2-6	176,24
2025C 10	2 1/2"	8.853	2	429,81
2025C 11	3"	12.842	1	615,25
2025C 12	4"	19.707	1	951,79

Precios rosca NPT a consultar / NPT thread prices on request

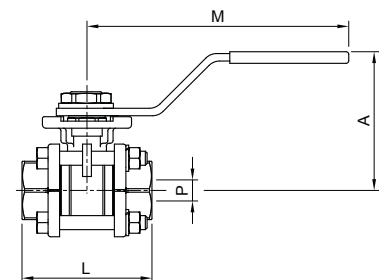

Ref.2026



Válvula esfera paso total 3 piezas. Butt weld ANSI B 16.25

Const.: acero inox. CF8M (316) microfundición. Juntas y asientos PTFE+15% FV tórica eje: vitón PN 63. Temp. -25°C +180°C. Mando manual por palanca. Montaje directo S/ ISO 5211 con sistema de bloqueo.

3 pcs full bore ball valve. Butt weld ANSI B 16.25

Const.: stainless steel CF8M (316) investment casting. Seats and seals: PTFE +15% GF o'ring stem: viton PN 63. Temp. -25°C +180°C. Manually operated by handle. Direct assembling ISO 5211 with locking system.

1000 WOG -13°F + 356°F

MED.	P	L	A	M	T	B	ISO 5211
1/4"	11	47,6	60	112	13	11	F-03
3/8"	12,7	47,6	60	112	14,7	12,7	F-03
1/2"	15	56	60	112	17	15	F-03/F-04
3/4"	20	73	70	138	22	20	F-04/F-05
1"	25	82	70	138	28	25	F-04/F-05
1 1/4"	32	91	88	160	35	32	F-05/F-07
1 1/2"	40	104	94	205	43	40	F-05/F-07
2"	50	120	100	205	54	50	F-05/F-07
2 1/2"	65	155	150	325	69	65	F-07/F-10
3"	80	182	165	325	87	80	F-07/F-10
4"	100	230	175	325	105	100	F-07/F-10



Información técnica
Technical information

CÓDIGO CODE	MEDIDA SIZE	PESO WEIGHT	CAJA / BOX CARTON	P.V.P. € PRICE €
2026 02	1/4"	0.376	8-64	23,80
2026 03	3/8"	0.365	8-64	23,80
2026 04	1/2"	0.425	6-54	26,10
2026 05	3/4"	0.794	3-27	40,89
2026 06	1"	0.997	2-20	49,67
2026 07	1 1/4"	1.865	8	79,81
2026 08	1 1/2"	2.437	4-8	103,49
2026 09	2"	3.483	2-6	147,39
2026 10	2 1/2"	8.689	2	365,36
2026 11	3"	12.448	1	514,62
2026 12	4"	19.437	1	862,93

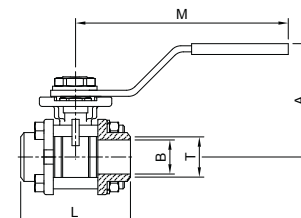

Ref.2027



Válvula esfera paso total 3 piezas socket weld ANSI B 16.11

Const.: acero inox. CF8M (316) microfundición. Juntas y asientos PTFE+15% FV tórica eje: vitón. PN 63. Temp. -25°C +180°C mando manual por palanca. Montaje directo s/DIN 5211 con sistema de bloqueo.

3 pcs full bore ball valve socket weld ANSI B 16.11

Const.: stainless steel CF8M (316) investment casting. Seats and seals: PTFE +15% GF o'ring stem: viton. PN 63. Temp. -25°C +180°C. Manually operated by handle. Direct assembling ISO 5211 with locking system.

1000 WOG -13°F + 356°F

MED.	P	L	A	M	S	K	ISO 5211
1/4"	11	47,6	60	112	14,1	10	F-03
3/8"	12,7	47,6	60	112	17,6	10	F-03
1/2"	15	56	60	112	21,7	14	F-03/F-04
3/4"	20	73	70	138	27,1	10	F-04/F-05
1"	25	82	70	138	33,8	14	F-04/F-05
1 1/4"	32	91	88	160	42,6	15	F-05/F-07
1 1/2"	40	104	94	205	48,7	15	F-05/F-07
2"	50	120	100	205	61,1	19	F-05/F-07
2 1/2"	65	155	150	325	73,8	21	F-07/F-10
3"	80	182	165	325	89,8	24	F-07/F-10
4"	100	220	175	325	115,5	35	F-07/F-10



Información técnica
Technical information

CÓDIGO CODE	MEDIDA SIZE	PESO WEIGHT	CAJA / BOX CARTON	P.V.P. € PRICE €
2027 02	1/4"	0.387	8-64	23,80
2027 03	3/8"	0.367	8-64	23,80
2027 04	1/2"	0.427	6-54	26,10
2027 05	3/4"	0.825	3-27	40,89
2027 06	1"	1.027	2-20	49,67
2027 07	1 1/4"	1.867	8	79,81
2027 08	1 1/2"	2.51	4-8	103,49
2027 09	2"	3.558	2-6	147,39
2027 10	2 1/2"	8.999	2	365,36
2027 11	3"	12.845	1	514,62
2027 12	4"	19.569	1	862,93

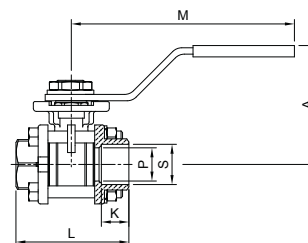

Ref.2034 - 2034N



Válvula esfera paso total 3 piezas

Rosca BSP, también disponible con rosca NPT (2034N). Const. acero al carbono "WCB" (microfundición). Esfera y eje inoxidable 316. Rosca ISO 7-1 (EN 10226-1). Asientos PTFE + 15% FV. 1000 wog. Temp. -25°C +180°C. Mando manual por palanca con sistema de bloqueo.

3 pcs full bore ball valve

BSP thread, also available with NPT thread (2034N). Const. carbon steel "WCB" (investment casting). Ball and stem: stainless steel 316. Thread ISO 7-1 (EN 10226-1). Seats: PTFE + 15% GF. 1000 wog. Temp. -25°C +180°C. Manually operated by handle with locking system.

MED.	A	L	M
1/4"	48	50	100
3/8"	48	50	100
1/2"	50	61	103
3/4"	60	70	127
1"	64	80	127
1 1/4"	79	93	154
1 1/2"	85	102	154
2"	87	124	192
2 1/2"	117	156	244
3"	125	179	244
4"	173	218	330



Información técnica
Technical information

CÓDIGO CODE	MEDIDA SIZE	PESO WEIGHT	CAJA / BOX CARTON	P.V.P. € PRICE €
2034 02	1/4"	0.283	12-72	15,80
2034 03	3/8"	0.264	12-72	15,80
2034 04	1/2"	0.361	9-54	20,34
2034 05	3/4"	0.612	6-36	25,95
2034 06	1"	0.812	4-24	33,07
2034 07	1 1/4"	1.453	2-12	51,93
2034 08	1 1/2"	1.755	4-12	63,66
2034 09	2"	3.126	3-6	116,41
2034 10	2 1/2"	6.207	3	215,84
2034 11	3"	9.148	2	312,56
2034 12	4"	19.817	1	687,39

Precios rosca NPT a consultar / NPT thread prices on request

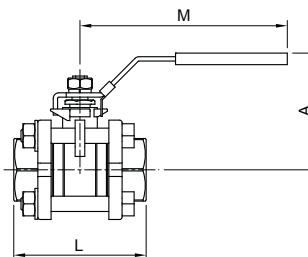

Ref.2034S



Válvula esfera paso total 3 piezas socket weld ANSI B 16.11

Const. acero al carbono "WCB" (microfundición). Esfera y eje inoxidable 316. Asientos PTFE + 15% FV. 1000 wog. Temp. -25°C +180°C. Mando manual por palanca con sistema de bloqueo.

3 pcs full bore ball valve socket weld ANSI B 16.11

Const. carbon steel "WCB" (investment casting). Ball and stem: stainless steel 316. Seats: PTFE + 15% GF. 1000 wog. Temp. -25°C +180°C. Manually operated by handle with locking system.

MED.	A	L	M	S	K
1/4"	48	50	100	14,1	10
3/8"	48	50	100	17,6	10
1/2"	50	61	103	21,7	10
3/4"	60	70	127	33,8	14
1"	64	80	127	33,8	14
1 1/4"	79	93	154	42,6	15
1 1/2"	85	102	154	48,7	15
2"	87	124	192	61,1	19
2 1/2"	117	156	244	73,8	21
3"	125	179	244	89,8	24
4"	173	218	330	115,5	25



Información técnica
Technical information

CÓDIGO CODE	MEDIDA SIZE	PESO WEIGHT	CAJA / BOX CARTON	P.V.P. € PRICE €
2034S 02	1/4"	0.271	12-72	15,80
2034S 03	3/8"	0.252	12-72	15,80
2034S 04	1/2"	0.352	9-54	20,34
2034S 05	3/4"	0.602	6-36	25,95
2034S 06	1"	0.803	4-24	33,07
2034S 07	1 1/4"	1.43	2-12	51,93
2034S 08	1 1/2"	1.731	4-12	63,66
2034S 09	2"	3.061	3-6	116,41
2034S 10	2 1/2"	6.334	3	215,84
2034S 11	3"	9.064	2	312,56
2034S 12	4"	19.571	1	687,39

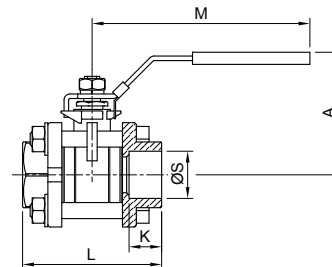

Ref. 2040 - 2041 - 2040N - 2041N



Válvula esfera 3 vías paso reducido

Art. 2040/2040N: Paso tipo L / Art. 2041/2041N: Paso tipo T

Const.: AISI 316 - Cuatro asientos PTFE+FV juntas cuerpo y eje: PTFE tórica eje: Vitón. Art. 2040-2041: Extremos Rosca ISO 7-1 (EN 10226-1). Art. 2040N-2041N: Extremos Rosca NPT. PN 63. Temp. -25°C +180°C. Montaje directo S/ISO 5211. Mando manual por palanca con sistema de bloqueo.

3 Ways ball valve reduced bore

Art. 2040/2040N: "L" bore / Art. 2041/2041N: "T" bore.

Const.: AISI 316; Four seats PTFE + GF body and stem seats: PTFE o'ring stem: Viton. Art. 2040-2041: Threaded ends ISO 7-1 (EN 10226-1). Art. 2040N-2041N: NPT theraded ends. PN 63. Temp. -25°C +180°C. Direct assembling S/ISO 5211. Manually operated by handle with locking system.

MED.	P	A	B	L	M
1/4"	9,5	66	57,5	75	130
3/8"	11	66	57,5	75	130
1/2"	12	66	57,5	75	130
3/4"	15	72	65,5	85	161
1"	20	77	79	100	161
1 1/4"	25	92	97	122	203
1 1/2"	32	96	106,5	131	203
2"	40	107	129	158	203
2 1/2"	49	135	145	178	254



Información técnica
Technical information

CÓDIGO CODE	MEDIDA SIZE	PESO WEIGHT	P.V.P. € PRICE €
2040 / 2041 / 2040N / 2041N			
2040 02	1/4"	0.724	70,05
2040 03	3/8"	0.686	70,05
2040 04	1/2"	0.633	71,81
2040 05	3/4"	0.994	86,69
2040 06	1"	1.487	119,09
2040 07	1 1/4"	3.015	206,06
2040 08	1 1/2"	3.773	252,49
2040 09	2"	6.453	418,29
2040 10	2 1/2"	9.088	802,99

Precios rosca NPT a consultar / NPT thread prices on request

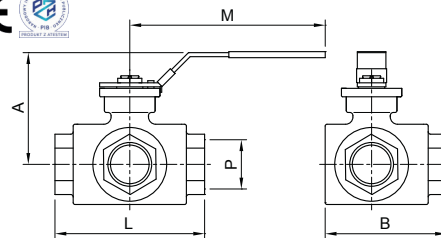

Ref.2048



Válvula esfera paso total con record dos piezas

Const.: acero inox. CF8M (316) microfundición. Extremos: M-H rosca ISO 7-1 (EN 10226-1). Asientos:PTFE + 15% FV. Tórica eje Viton. PN 63, Temp: -25°C + 180°C. Mando manual por palanca con sistema bloqueo.

Full bore ball valve with 2 pieces connector

Const. stainless steel CF8M (316) investment casting. Threaded ends M-F ISO 7-1 (EN 10226-1). Seats: PTFE + 15% GF. O'ring Stem: viton. PN 63. Temp: -25°C + 180°C. Manually operated by handle with locking system.

MED.	A	L	M
1"	62	110	122
1 1/4"	80	125	180
1 1/2"	85	136	180



Información técnica
Technical information

2048 06	1"	0.766	36,99
2048 07	1 1/4"	1.325	57,04
2048 08	1 1/2"	1.845	81,27

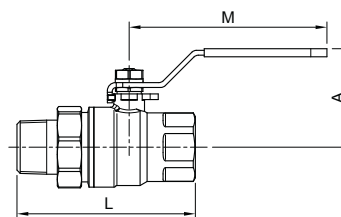

Ref.2052



Válvula esfera paso total fondo de cubas

Const. acero inox. CF8M (316) y 316L (fondo de cubas).
Extremo rosca ISO 7-1 (EN 10226-1) y fondo de cubas.
Asientos PTFE + 15% FV. Tórica eje vitón.
PN 63. Temp. -25°C +180°C. Montaje directo S/ISO 5211.
Mando manual por palanca con sistema de bloqueo.

Tank bottom full bore ball valve

Const. stainless steel CF8M (316) and 316L (tank bottom).
Ends: thread ISO 7-1 (EN 10226-1) and tank bottom.
Seats: PTFE + 15% FV. O'ring stem: viton. PN 63.
Temp. -25°C +180°C. Direct assembling ISO 5211.
Manually operated by handle with locking system.

MED.	A	L	M	T
1/2"	60	65,5	112	24
3/4"	70	76,2	138	30
1"	70	83,3	138	33,5
1 1/4"	88	91,3	160	41,5
1 1/2"	94	103,3	205	51,5
2"	100	116,5	205	63
2 1/2"	150	147,3	325	83,5
3"	165	169	325	100
4"	175	198	325	118,5



Información técnica
Technical information

CÓDIGO CODE	MEDIDA SIZE	PESO WEIGHT	P.V.P. € PRICE €
2052 04	1/2"	0.44	226,97
2052 05	3/4"	0.82	266,27
2052 06	1"	1.76	311,18
2052 07	1 1/4"	1.79	508,79
2052 08	1 1/2"	4.14	533,65
2052 09	2"	5.32	700,02
2052 10	2 1/2"	12.5	1084,47
2052 11	3"	17.12	1372,77
2052 12	4"	19.65	1935,29

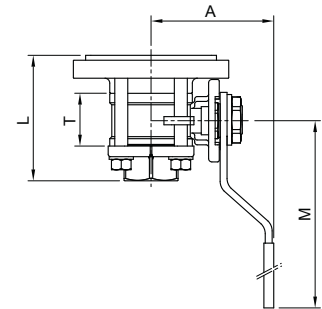

Ref.2053



Válvula esfera paso total fondo de cubas Butt weld

Const. acero inox. CF8M (316) y 316L (fondo de cubas).
Extremo butt weld ANSI B 16.25 y fondo de cubas.
Asientos PTFE + 15% FV. Tórica eje vitón.
PN 63. Temp. -25°C +180°C. Montaje directo s/ISO 5211.
Mando manual por palanca con sistema de bloqueo.

Tank bottom full bore ball valve Butt weld

Const. stainless steel CF8M (316) and 316L (tank bottom).
Ends: butt weld ANSI B 16.25 and tank bottom.
Seats: PTFE + 15% FV. O'ring stem: viton. PN 63.
Temp. -25°C +180°C. Direct assembling ISO 5211.
Manually operated by handle with locking system.

MED.	A	L	M	T
1/2"	60	65,5	112	24
3/4"	70	76,2	138	30
1"	70	83,3	138	33,5
1 1/4"	88	91,3	160	41,5
1 1/2"	94	103,3	205	51,5
2"	100	116,5	205	63
2 1/2"	150	147,3	325	83,5
3"	165	169	325	100
4"	175	203	325	118,5



Información técnica
Technical information

CÓDIGO CODE	MEDIDA SIZE	PESO WEIGHT	P.V.P. € PRICE €
2053 04	1/2"	0.44	226,97
2053 05	3/4"	1.66	266,27
2053 06	1"	1.02	311,18
2053 07	1 1/4"	1.79	503,85
2053 08	1 1/2"	3.66	528,46
2053 09	2"	3.47	693,22
2053 10	2 1/2"	8.5	1084,47
2053 11	3"	15.64	1372,77
2053 12	4"	16.65	1935,29

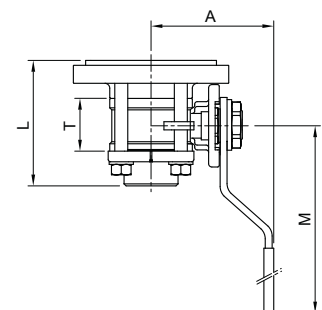

Ref.2035



Válvula esfera paso reducido 1 pieza

Const. cuerpo: acero carbono DIN ST-37. Extremos prolongados para soldar. Esfera INOX. 304. Eje INOX. 303. Asientos PTFE + grafito. Tóricas eje viton. PN 25/40. Temp. -30°C +200°C. Mando manual por palanca hasta 6". Reductor manual >6".

1 pc reduce bore ball valve. District heating

Const. carbon steel DIN ST-37. Extended butt weld ends. Ball: SS 304. stem: ss 303. Seats: PTFE + graphite. O'rings stem: viton. PN 25/40. Temp. -30°C +200°C. Manually operated by handle, until 6". Gear operator >6".

DN	D	A	L	M
15	21,3	100	230	120
20	26,9	100	230	120
25	33,7	105	230	150
32	42,2	105	260	150
40	48,2	125	260	190
50	60,3	130	300	190
65	76,1	180	300	280
80	88,9	190	300	280
100	114,3	220	325	280
125	139,7	245	325	420
150	168,3	265	350	550
200	219,1	*	400	*
250	273	*	530	*
300	323,9	*	550	*



Información técnica
Technical information

CÓDIGO CODE	MEDIDA SIZE	PESO WEIGHT	P.V.P. € PRICE €
2035 04	1/2"	1	40,31
2035 05	3/4"	1.2	46,27
2035 06	1"	1.4	57,44
2035 07	1 1/4"	1.8	62,40
2035 08	1 1/2"	2.6	80,57
2035 09	2"	3.6	91,00
2035 10	2 1/2"	5.2	138,92
2035 11	3"	6.6	185,19
2035 12	4"	9.8	264,48
2035 13	5"	14.5	425,17
2035 14	6"	22.3	591,42
2035 16	8"	56	1243,36
2035 18	10"	87.5	2519,49
2035 20	12"	130	3687,07

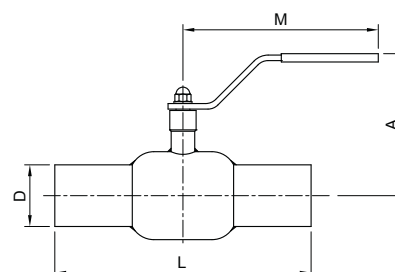

Ref.2102 - D2102



Válvula de compuerta con cierre de EPDM y cuerpo de fundición nodular PN 16

Vástago fijo. Diseño según DIN 3352, DIN 2501, DIN 3202-F4 apta para conducción de agua. Temp. máx. de trabajo 80°C.

Gate valve with EPDM seal and ductile iron body PN 16

Fixed stem. Design according to DIN 3352, DIN 2501, DIN 3202-F4. Suitable for water conduction. Max. working temp. 80°C.

Adaptador opcional

Optional adapter

DN	A	B	C	D
50	150	240	180	165
65	170	270	180	185
80	180	300	200	200
100	190	330	250	220
125	200	375	280	250
150	210	425	280	285
200	230	515	320	340
250	250	600	350	405
300	270	685	400	460

2102 09	2"	8.989	112,46
2102 10	2 1/2"	11.603	135,45
2102 11	3"	13.172	167,95
2102 12	4"	16.417	219,78
2102 13	5"	24.222	305,16
2102 14	6"	32.332	402,07
2102 16	8"	51.942	649,48
2102 18	10"	83.747	931,20
2102 20	12"	112.797	1394,19
D2102 09	2" - 4"	0.58	24,39
D2102 13	5"-6"	0.7	24,39
D2102 16	8"	0.511	24,41
D2102 18	10"-12"	0.462	28,19



Información técnica
Technical information

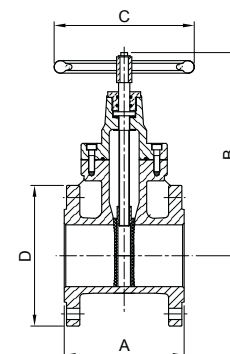

Ref.2104 - 5104



Válvula mariposa tipo wafer Montaje entre bridas PN 10/16 - ANSI 150 lbs

Cuerpo, eje y disco: inoxidable 316 (CF8M).
Asiento: PTFE con base de EPDM. Temp. -25°C +180°C.
Mando manual por palanca de inoxidable hasta 5", mayor de 6" con reductor. Longitud entre caras según DIN 3202K1. Presión de trabajo: 10 bar

Wafer type butterfly valve Mounting between flanges PN 10/16 - ANSI 150 lbs

Body, stem and disc: stainless steel 316 (CF8M).
Seat: PTFE with EPDM backup ring. Temp. -25°C +180°C.
Manually operated by stainless steel handle until 5", from 6" with gear operator. Face to face according to DIN 3202 K1. Working pressure: 10 bar

Art. 5104 de 2" a 5" con reductor manual.

Art. 5104 from 2" to 5" with gear operator.

MED.	L	A1	A2	D	P
2"	43	168	74	65	270
2 1/2"	46	170	82	65	270
3"	46	170	90	65	270
4"	52	190	116	90	270
5"	56	206	132	90	270
6"	56	222	145	90	-
8"	60	274	180	125	-
10"	68	310	210	125	-

CÓDIGO CODE	MEDIDA SIZE	PESO WEIGHT	P.V.P. € PRICE €
2104 09	2"	2.757	501,06
2104 10	2 1/2"	3.367	606,55
2104 11	3"	3.636	738,42
2104 12	4"	5.543	949,41
2104 13	5"	7.383	1160,38
2104 14	6"	10.834	1476,84
2104 16	8"	18.081	2577,75
2104 18	10"	25.347	4044,16

5104 09	2"	4.2	596,73
5104 10	2 1/2"	4.8	753,17
5104 11	3"	4.72	812,64
5104 12	4"	7.95	1004,56
5104 13	5"	9.65	1196,48

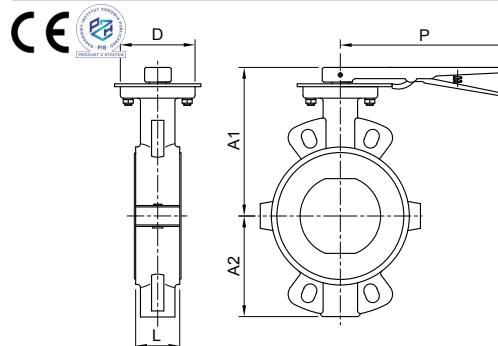

Información técnica
Technical information

Ref.2101 - 5101



Válvula mariposa tipo wafer Montaje entre bridas PN 10/16 - ANSI 150 lbs

Cuerpo fundición nodular GGG-40. Eje y disco: Inox. 316.
Asiento: PTFE con base de silicona. Temp. -25°C +180°C.
Mando manual por palanca hasta 5", mayor de 5" con reductor de fundición. Longitud entre caras según DIN 3202K1. Presión de trabajo: 10 bar

Wafer type butterfly valve Mounting between flanges PN 10/16 - ANSI 150 lbs

Body, ductile iron GGG-40. Stem and disc: stainless steel 316.
Seat: PTFE with silicone backup ring. Temp. -25°C +180°C.
Manually operated by handle until 5", from 6" with cast iron gear operator. Face to face according to DIN 3202 K1. Working pressure: 10 bar

Art. 5101 de 2" a 5" con reductor manual.

Art. 5101 from 2" to 5" with gear operator.

MED.	L	D	P	A1	A2
2"	43	70	172	136	75
2 1/2"	46	70	172	145	80
3"	46	70	172	153	85
4"	52	90	218	170	114
5"	56	90	218	185	127
6"	56	90	***	200	140
8"	60	125	***	231	175

2101 09	2"	2.771	342,15
2101 10	2 1/2"	3.162	373,36
2101 11	3"	3.582	515,50
2101 12	4"	5.689	690,16
2101 13	5"	7.582	836,54
2101 14	6"	12.722	1033,24
2101 16	8"	22.359	1850,02

5101 09	2"	4.42	429,26
5101 10	2 1/2"	4.68	463,01
5101 11	3"	5.04	603,82
5101 12	4"	7.03	776,47
5101 13	5"	8.37	921,43

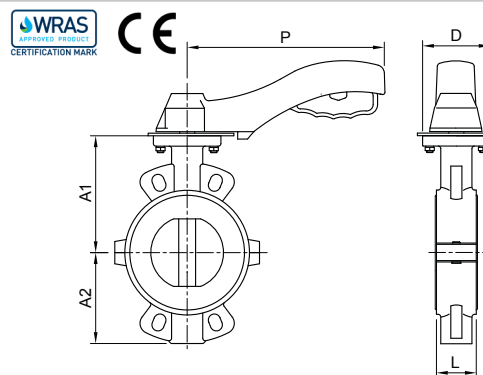

Información técnica
Technical information

Ref. 2101T - 5101T **NEW**



Válvula mariposa tipo wafer Montaje entre bridas PN 10/16 - ANSI 150 lbs

Cuerpo fundición nodular GGG-40. Disco: Inox. 316 + PTFE
Asiento: PTFE con base de silicona. Temp. -25°C +180°C.
Mando manual por palanca hasta 5", mayor de 5" con reductor de fundición.
Longitud entre caras según DIN 3202K1.
Presión de trabajo: 10 bar

Wafer type butterfly valve Mounting between flanges PN 10/16 - ANSI 150 lbs

Body, ductile iron GGG-40. Disc: stainless steel 316 + PTFE
Seat: PTFE with silicone backup ring. Temp. -25°C +180°C.
Manually operated by handle until 5", from 6" with cast iron gear operator.
Face to face according to DIN 3202 K1. Working pressure: 10 bar

Art. 5101T de 2" a 5" con reductor manual.

Art. 5101T from 2" to 5" with gear operator.

MED.	L	D	P	A1	A2
2"	43	70	172	136	75
2 1/2"	46	70	172	145	80
3"	46	70	172	153	85
4"	52	90	218	170	114
5"	56	90	218	185	127
6"	56	90	***	200	140
8"	60	125	***	231	175

CÓDIGO CODE	MEDIDA SIZE	PESO WEIGHT	P.V.P. € PRICE €
2101T 09	2"	2.8	286,32
2101T 10	2 1/2"	3.2	375,19
2101T 11	3"	3.6	477,23
2101T 12	4"	5.6	575,98
2101T 13	5"	7.6	789,91
2101T 14	6"	13	1020,26
2101T 16	8"	17.4	1606,08

5101T 09	2"	2.8	414,36
5101T 10	2 1/2"	3.2	503,23
5101T 11	3"	3.6	605,27
5101T 12	4"	5.6	722,15
5101T 13	5"	7.6	936,08

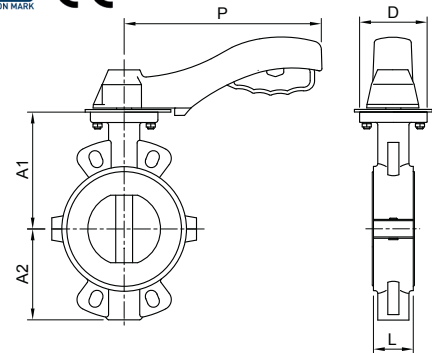

Información técnica
Technical information

Ref. 2108 - 5108



Válvula mariposa tipo Lug Montaje entre bridas PN 10/16

PN 16 ≤ DN 150 - PN 10 ≥ DN 200.
Cuerpo fundición nodular GGG-40. Disco CF8M (316).
Elastómero EPDM. Tóricas eje NBR.
Temperatura de trabajo -20°C +120°C.
Montaje actuador s / ISO 5211. Palanca hasta 10".
Reductor manual a partir de 12".

Lug type butterfly valve Mounting between DIN PN 10/16 flanges

PN 16 ≤ DN 150 - PN 10 ≥ DN 200.
Body: ductile iron GGG-40. Disc: CF8M (316).
Seat: EPDM. Stem o'ring NBR.
Working temperature -20°C +120°C.
Mounting actuator according to ISO 5211 std.
Handle up to 10" with gear operator from 12".

Art. 5108 de 2" a 5" con reductor manual.

Art. 5108 from 2" to 5" with gear operator.

MED.	L	A1	A2	D	P
2"	43	240	79	90	216
2 1/2"	46	240	93	90	216
3"	46	245	103	90	216
4"	52	265	120	90	216
5"	56	290	133	90	216
6"	56	240	158	125	300
8"	60	280	180	125	300
10"	68	325	216	125	300
12"	78	351	251	150	-

2108 09	2"	4.161	63,85
2108 10	2 1/2"	4.628	77,29
2108 11	3"	5.771	86,61
2108 12	4"	7.799	118,20
2108 13	5"	9.462	171,35
2108 14	6"	12.964	205,08
2108 16	8"	17.494	326,73
2108 18	10"	29.322	521,74
2108 20	12"	53.075	787,99

5108 09	2"	10	164,12
5108 10	2 1/2"	10.14	182,77
5108 11	3"	11.24	192,00
5108 12	4"	14.04	223,13
5108 13	5"	14	268,79
5108 14	6"	16.78	294,87
5108 16	8"	25.56	448,40
5108 18	10"	37.83	614,18

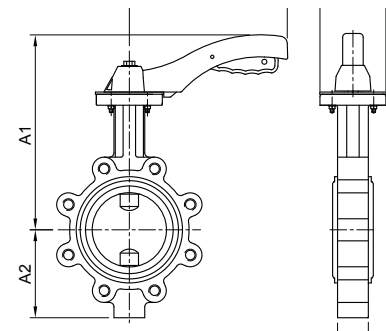

Información técnica
Technical information

Ref. 2108B - 5108B



**Válvula mariposa tipo Lug
Montaje entre bridas PN 10/16**
Cuerpo fundición nodular GGG-40. Disco CF8M (316)
Elastómero en NBR. Tóricas eje NBR.
Temperatura de trabajo -20°C +110°C.
Montaje actuador s/ISO 5211. Palanca hasta 10".
Reductor manual a partir de 12".

**Lug type butterfly valve
Mounting between DIN PN 10/16 flanges**

Body: ductil iron GGG-40. Disc: CF8M (316).
Elastomer: NBR. Stem o'ring NBR.
Working temperature -20°C +110°C.
Mounting actuator according to ISO 5211 std.
Handle up to 10" with gear operator from 12".

Art. 5108B de 2" a 10" con reductor manual.

Art. 5108B from 2" to 10" with gear operator.

MED.	L	A1	A2	D	P
2"	43	240	79	90	216
2 1/2"	46	240	93	90	216
3"	46	245	103	90	216
4"	52	265	120	90	216
5"	56	290	133	90	216
6"	56	240	158	125	300
8"	60	280	180	125	300
10"	68	325	216	125	300
12"	78	351	251	150	

CÓDIGO CODE	MEDIDA SIZE	PESO WEIGHT	P.V.P. € PRICE €
2108B 09	2"	4.183	67,05
2108B 10	2 1/2"	4.667	81,16
2108B 11	3"	5.817	90,94
2108B 12	4"	7.883	124,11
2108B 13	5"	9.45	179,92
2108B 14	6"	13.127	215,33
2108B 16	8"	17.667	343,06
2108B 18	10"	29.467	547,83
2108B 20	12"	49.933	827,39

5108B 09	2"	8.5	172,33
5108B 10	2 1/2"	8.84	191,91
5108B 11	3"	8.41	201,60
5108B 12	4"	11	234,28
5108B 13	5"	13	282,23
5108B 14	6"	12.5	309,62
5108B 16	8"	26.6	470,82
5108B 18	10"	24.2	644,89

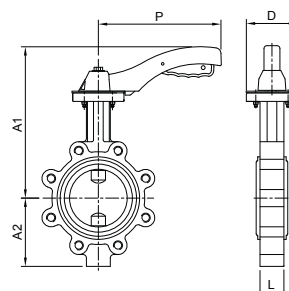

Información técnica
Technical information

Ref. 2108A - 5108A



**Válvula mariposa tipo Lug
Montaje entre bridas ANSI 125/150**
Cuerpo fundición nodular GGG-40. Disco CF8M (316)
Elastómero EPDM. Tóricas eje NBR.
Temperatura de trabajo -20°C +110°C.
Montaje actuador s/ISO 5211. Palanca hasta 10".
Reductor manual a partir de 12".

**Lug type butterfly valve
Mounting between ANSI class 125/150 flanges**

Body: ductil iron GGG-40. Disc: CF8M (316).
Seat: EPDM. Stem o'ring NBR.
Working temperature -20°C +110°C.
Mounting actuator according to ISO 5211 std.
Handle up to 10" with gear operator from 12".

Art. 5108A de 2" a 10" con reductor manual.

Art. 5108A from 2" to 10" with gear operator.

MED.	L	A1	A2	D	P
2"	43	240	79	90	216
2 1/2"	46	240	93	90	216
3"	46	245	103	90	216
4"	52	265	120	90	216
5"	56	290	133	90	216
6"	56	240	158	125	300
8"	60	280	180	125	300
10"	68	325	216	125	300
12"	78	351	251	150	-
14"	78	346	262	150	-
16"	102	375	301	175	-
18"	114	400	333	175	-
20"	127	432	366	175	-

2108A 09	2"	4.148	66,73
2108A 10	2 1/2"	4.59	80,80
2108A 11	3"	4.87	90,53
2108A 12	4"	7.819	124,15
2108A 13	5"	9.333	180,04
2108A 14	6"	13.001	215,44
2108A 16	8"	17.596	343,25
2108A 18	10"	28.689	548,12
2108A 20	12"	51.955	847,56
2108A 22	14"	69.824	1705,65
2108A 24	16"	96.516	2485,75
2108A 26	18"	133.984	3233,08
2108A 28	20"	190.163	4670,89

5108A 09	2"	8.71	164,12
5108A 10	2 1/2"	9.114	182,77
5108A 11	3"	9.49	192,00
5108A 12	4"	12.29	223,13
5108A 13	5"	13	268,79
5108A 14	6"	16.73	294,87
5108A 16	8"	26.9	448,40
5108A 18	10"	37.2	614,18

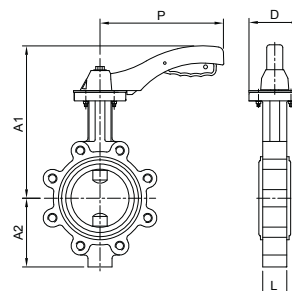

Información técnica
Technical information

Ref. 2108AB - 5108AB



**Válvula mariposa tipo Lug
Montaje entre bridas ANSI 125/150**
Cuerpo fundición nodular GGG-40. Disco CF8M (316)
Elastómero NBR. Tóricas eje NBR.
Temperatura de trabajo -20°C +110°C.
Montaje actuador s/ISO 5211. Palanca hasta 10".
Reductor manual a partir de 12".

**Lug type butterfly valve
Mounting between ANSI class 125/150 flanges**
Body: ductil iron GGG-40. Disc: CF8M (316).
Seat: NBR. Stem o'ring NBR.
Working temperature -20°C +110°C.
Mounting actuator according to ISO 5211 std.
Handle up to 10" with gear operator from 12".

**Art. 5108AB de 2" a 10" con reductor manual.
Art. 5108AB from 2" to 10" with gear operator.**

MED.	L	A1	A2	D	P
2"	43	240	79	90	216
2 1/2"	46	240	93	90	216
3"	46	245	103	90	216
4"	52	265	120	90	216
5"	56	290	133	90	216
6"	56	240	158	125	300
8"	60	280	180	125	300
10"	68	325	216	125	300
12"	78	351	251	150	-

CÓDIGO CODE	MEDIDA SIZE	PESO WEIGHT	P.V.P. € PRICE €
2108AB 09	2"	4.149	70,06
2108AB 10	2 1/2"	4.567	84,83
2108AB 11	3"	4.817	95,06
2108AB 12	4"	7.774	130,36
2108AB 13	5"	9.235	189,04
2108AB 14	6"	12.854	226,21
2108AB 16	8"	17.428	360,42
2108AB 18	10"	28.543	575,53
2108AB 20	12"	49.51	889,94

5108AB 09	2"	8.71	172,33
5108AB 10	2 1/2"	9.114	191,91
5108AB 11	3"	9.49	201,60
5108AB 12	4"	12.29	234,28
5108AB 13	5"	13	282,23
5108AB 14	6"	16.73	309,62
5108AB 16	8"	26.9	470,82
5108AB 18	10"	1	644,89

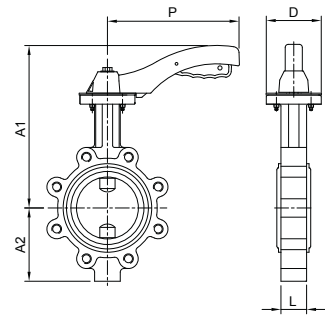

Información técnica
Technical information

Ref. 2103 - 5103



**Válvula mariposa tipo wafer
PN 10/16. ANSI 150 lbs**
Cuerpo hierro fundido.+epoxy. Disco fundición nodular zincado. Elastómero EPDM. Tóricas eje NBR. Temp. máx. 120°C. Brida montaje actuadores s/ISO 5211. Palanca hasta 10" y con reductor manual a partir de 12".

Wafer type butterfly valve PN 10/16 ANSI 150 lbs
Body: cast iron + epoxy. Disk: zinc plated. Elastomer: EPDM. O'ring stem: NBR. Max. temp. 120°C. Flanges mounted actuators ISO 5211 handle up to 10" and with gear operator from 12".

**Art. 5103 de 2" a 10" con reductor manual.
Art. 5103 from 2" to 10" with gear operator.**

MED.	L	A1	A2	D	P	PN
2"	43	238	70	65	170	16
2 1/2"	46	238	80	65	170	16
3"	46	238	100	65	170	16
4"	52	270	115	90	215	16
5"	56	300	135	90	215	16
6"	56	300	150	90	215	16
8"	60	280	180	125	300	16
10"	68	330	215	125	300	16
12"	78	360	250	150	-	16
14"	78	390	260	150	-	10
16"	102	420	300	175	-	10
18"	114	445	330	175	-	10
20"	127	480	370	175	-	10

2103 09	2"	2.723	45,37
2103 10	2 1/2"	3.226	54,85
2103 11	3"	3.713	60,66
2103 12	4"	5.677	70,37
2103 13	5"	7.305	84,95
2103 14	6"	8.341	100,85
2103 16	8"	15.016	151,97
2103 18	10"	21.444	283,69
2103 20	12"	38.846	487,80
2103 22	14"	52.522	559,15
2103 24	16"	73.333	1172,11
2103 26	18"	114.39	1578,23
2103 28	20"	140.183	2595,89

5103 09	2"	7.56	133,86
5103 10	2 1/2"	7.7	148,09
5103 11	3"	9.32	160,07
5103 12	4"	10.25	163,28
5103 13	5"	12.2	175,58
5103 14	6"	12.95	184,60
5103 16	8"	22.85	257,79
5103 18	10"	29.64	376,09

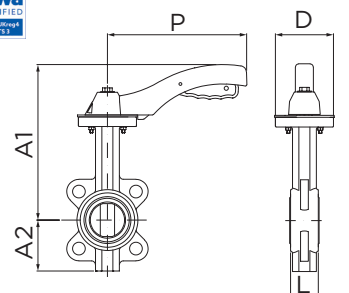

Información técnica
Technical information

Ref. 2109 - 5109



Válvula mariposa tipo wafer PN-10/16. ANSI 150 lbs

Cuerpo hierro fundido + epoxy - disco acero inox. AISI 316.
Elastómero EPDM. Tóricas eje NBR. Temp. máx. 120°C.
Brida montaje actuadores S/ISO 5211. Palanca hasta 10" y reductor manual a partir de 12".

Wafer type butterfly valve PN 10/16. ANSI 150 lbs

Body: cast iron + epoxy. Disk: stainless steel AISI 316.
Elastomer: EPDM. O'ring stem: NBR. Max. temp. 120°C.
Flanges mounted actuators ISO 5211.
Handle up to 10" and with gear operator from 12".

Art. 5109 de 2" a 10" con reductor manual.

Art. 5109 from 2" to 10" with gear operator.

MED.	L	A1	A2	D	P	PN
2"	43	238	70	65	170	16
2 1/2"	46	238	80	65	170	16
3"	46	238	100	65	170	16
4"	52	270	115	90	215	16
5"	56	300	135	90	215	16
6"	56	300	150	90	215	16
8"	60	280	180	125	300	16
10"	68	330	215	125	300	16
12"	78	360	250	150	-	16
14"	78	390	260	150	-	10
16"	102	420	300	175	-	10
18"	114	445	330	175	-	10
20"	127	480	370	175	-	10



Información técnica
Technical information

CÓDIGO CODE	MEDIDA SIZE	PESO WEIGHT	P.V.P. € PRICE €
2109 09	2"	2.663	54,71
2109 10	2 1/2"	3.134	66,47
2109 11	3"	3.604	76,23
2109 12	4"	5.529	103,52
2109 13	5"	6.976	127,86
2109 14	6"	7.922	159,93
2109 16	8"	14.711	287,32
2109 18	10"	22.113	399,10
2109 20	12"	39.46	713,55
2109 22	14"	54.861	1018,73
2109 24	16"	76.167	1720,70
2109 26	18"	118.377	2325,91
2109 28	20"	142.495	3755,39

5109 09	2"	8.5	143,89
5109 10	2 1/2"	8.84	160,36
5109 11	3"	8.41	169,78
5109 12	4"	11	196,03
5109 13	5"	13	220,44
5109 14	6"	12.5	241,88
5109 16	8"	26.6	383,99
5109 18	10"	24.2	472,01

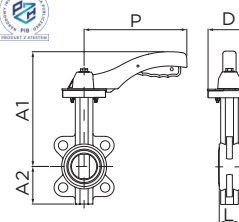

Ref. 2109B - 5109B



Válvula mariposa tipo wafer PN-10/16. ANSI 150 lbs

Cuerpo hierro fundido + epoxy disco acero inox. AISI 316.
Elastómero en NBR. Tóricas eje NBR. Temp. máx. 110°C.
Brida montaje actuadores S/ISO 5211. Palanca hasta 10" reductor manual a partir de 12".

Wafer type butterfly valve PN 10/16. ANSI 150 lbs

Body: cast iron + epoxy. Disk: stainless steel AISI 316.
Elastomer: NBR. O'ring stem: NBR. Max. temp. 110°C.
Flanges mounted actuators ISO 5211.
Handle up to 10" with gear operator from 12".

Art. 5109B de 2" a 10" con reductor manual.

Art. 5109B from 2" to 10" with gear operator.

MED.	L	A1	A2	D	P	PN
2"	43	238	70	65	170	16
2 1/2"	46	238	80	65	170	16
3"	46	238	100	65	170	16
4"	52	270	115	90	215	16
5"	56	300	135	90	215	16
6"	56	300	150	90	215	16
8"	60	280	180	125	300	16
10"	68	330	215	125	300	16
12"	78	360	250	150	-	16
14"	78	390	260	150	-	10
16"	102	420	300	175	-	10
18"	114	445	330	175	-	10
20"	127	480	370	175	-	10

2109B 09	2"	2.705	57,98
2109B 10	2 1/2"	3.154	70,46
2109B 11	3"	3.573	80,80
2109B 12	4"	5.568	109,73
2109B 13	5"	6.673	135,53
2109B 14	6"	8.076	169,51
2109B 16	8"	14.385	304,57
2109B 18	10"	22.013	423,03
2109B 20	12"	38.975	756,35
2109B 22	14"	56.3	1079,85
2109B 24	16"	73.813	1823,93
2109B 26	18"	118.8	2465,47
2109B 28	20"	143.3	3980,72

5109B 09	2"	5.8	151,09
5109B 10	2 1/2"	8.34	168,39
5109B 11	3"	9.24	178,26
5109B 12	4"	9	205,84
5109B 13	5"	10.4	231,46
5109B 14	6"	12	253,98
5109B 16	8"	24.9	403,19
5109B 18	10"	24.2	495,62

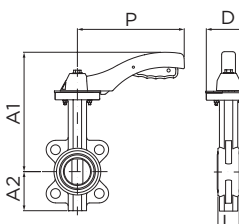

Información técnica
Technical information

Ref.2113



Válvula mariposa tipo wafer con reductor manual y microrruptor final de carrera. PN 10/16. ANSI 150 lbs..

Cuerpo fundición nodular GGG.40. Disco fundición nodular + EPDM. Diseño según API 609. Distancia entre caras según ASME B16.10. Presión de trabajo 300 PSI. Temp. de trabajo: 0°C +80°C.

Certificación UL/FM.

Wafer type butterfly valve with gear-box and limit switch. PN 10/16. ANSI 150 lbs

Body made of ductile iron GGG.40. Disc: D.I + EPDM. Design according to API 609. Face to face according to ASME B16.10. Working pressure 300 PSI. Working temperature: 0°C +80°C.

UL/FM certification.

MED.	L	A	B	H	K	J
2 1/2"	44,2	125	95	111	153	152
3"	45,3	140	100	111	153	152
4"	52	160	100	111	153	152
5"	54,4	170	125	111	153	152
6"	55,8	190	140	111	153	200
8"	60,5	230	175	126	210	300

CÓDIGO CODE	MEDIDA SIZE	PESO WEIGHT	P.V.P. € PRICE €
-------------	-------------	-------------	------------------

2113 10	2 1/2"	8.5	181,12
2113 11	3"	8.733	187,01
2113 12	4"	10.433	213,18
2113 13	5"	11.826	235,41
2113 14	6"	14.367	266,54
2113 16	8"	26.467	400,97

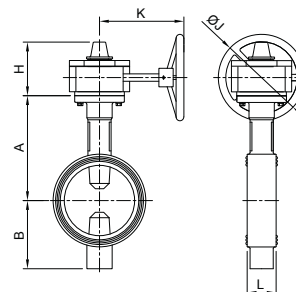

Información técnica
Technical information

Ref. 2114 - 2114D



Válvula mariposa - Extremos ranurados con reductor manual y microrruptor final de carrera

Cuerpo fundición nodular GGG.40. Disco fundición nodular + EPDM. Diseño según API 609. Ranurado según AWWA C606. Distancia entre caras según MSS SP-67.

Presión de trabajo 300 PSI. Temp. de trabajo: 0°C +80°C.

Certificación UL/FM.

Grooved ends Butterfly valve with gear-box and limit switch

Body made of ductile iron GGG.40. Disc: D.I + EPDM. Design according to API 609. Grooved standard AWWA C606. Face to face according to MSS SP-67.

Working pressure 300 PSI. Working temperature: 0°C +80°C.

UL/FM certification.

MED.	L	D	E	F	G	A	B	H	K	J
2 1/2"	96,8	73	69,1	15,9	7,9	125	95	111	153	152
3"	96,8	88,9	84,9	15,9	7,9	140	100	111	153	152
4"	115,8	114,3	110,1	15,9	9,5	160	100	111	153	152
5"	147,6	141,3	137	15,9	9,5	170	125	111	153	152
6"	147,6	168,3	164	15,9	9,5	190	140	111	153	200
8"	133,4	219,1	214,4	19	11,1	230	175	126	210	300
DN 65	96,8	76,1	72,3	15,9	7,9	125	95	111	153	152
DN 125	147,6	139,7	135,5	15,9	9,5	170	125	111	153	152
DN 150	147,6	165,1	160,9	15,9	9,5	190	140	111	153	200

2114 10	2 1/2"	8.163	183,95
2114 11	3"	8.575	190,78
2114 12	4"	9.88	213,12
2114 13	5"	12.855	253,46
2114 14	6"	14.871	277,89
2114 16	8"	27.463	441,80

2114D 10	DN 65	8.225	183,95
2114D 13	DN 125	12.79	253,46
2114D 14	DN 150	14.658	277,89

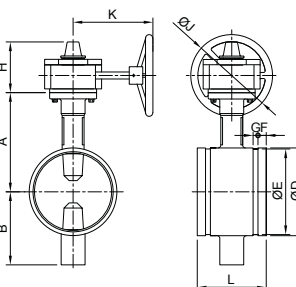

Información técnica
Technical information

Ref.2120 - 2120D



Válvula mariposa - Extremos ranurados

Cuerpo fundición nodular GGG.40. Disco fundición nodular + EPDM. Diseño según API 609. Ranurado según AWWA C606. Distancia entre caras según MSS SP-67. Presión de trabajo 300 PSI. Temp. de trabajo: 0°C +80°C.

Grooved ends butterfly valve

With handle up to 8" and with gear operator from 10". Body made of ductile iron GGG.40. Disc: D.I + EPDM. Design according to API 609. Grooved standard AWWA C606. Face to face according to MSS SP-67.

Working pressure 300 PSI. Working temperature: 0°C +80°C.

MED.	L	D	E	F	G	A	B	H	K
2"	81	60,3	57,2	15,9	7,9	110	85	32	267
2 1/2"	96,8	73	69,1	15,9	7,9	125	95	32	267
3"	96,8	88,9	84,9	15,9	7,9	140	100	32	267
4"	115,8	114,3	110,1	15,9	9,5	160	100	32	267
5"	147,6	141,3	137	15,9	9,5	170	125	32	267
6"	147,6	168,3	164	15,9	9,5	190	140	32	267
8"	133,4	219,1	214,4	19	11,1	200	175	37	353
10"	158,8	273	268,3	19	12,7	260	200	77	---
12"	165,1	323,8	318,3	19	12,7	300	240	77	---
DN 65	96,8	73	69,1	15,9	7,9	125	95	32	267
DN 125	147,6	141,3	137	15,9	9,5	170	125	32	267
DN 150	147,6	168,3	164	15,9	9,5	190	140	32	267

2120 09	2"	2.5	95,13
2120 10	2 1/2"	3.1	104,21
2120 11	3"	3.466	111,68
2120 12	4"	4.87	136,04
2120 13	5"	7.6	180,06
2120 14	6"	9.466	206,71
2120 16	8"	17.3	343,55
2120 18	10"	34.95	658,70
2120 20	12"	49.766	1074,39

2120D 10	DN 65	3.166	104,21
2120D 13	DN 125	9.5	180,06
2120D 14	DN 150	10.4	206,71

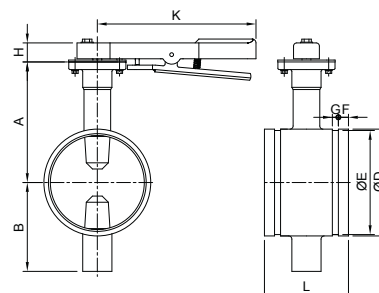

Información técnica
Technical information

Ref.2094



Válvula de compuerta cierre de EPDM – Extremos Bridados.
Válvula de compuerta cierre de EPDM – Extremos Bridados. Const. Cuerpo y bonete de fundición nodular GGG.40. Diseño según AWWA C515. Bridas ASME B16.42. Distancia entre caras según ASME B16.10. Husillo ascendente. Presión de trabajo 300 PSI. Temp. de trabajo: 0°C +80°C.
Certificación UL/FM.

Gate valve with EPDM seat – Flanged ends.

Gate valve with EPDM seat – Flanged ends. Body and bonnet made of ductile iron GGG.40. Design according to AWWA C515. Flanged ends standard ASME B16.42. Face to face according to ASME B16.10. Rising stem (OS&Y). Working pressure 300 PSI. Working temperature: 0°C +80°C.
UL/FM certification.

MED.	L	D	H	V
2 1/2"	190	178	370	190
3"	203	191	420	256
4"	229	229	447	256
5"	254	254	547	310
6"	267	279	607	310
8"	292	343	754	355
10"	330	406	890	446
12"	356	483	1031	446

CÓDIGO CODE	MEDIDA SIZE	PESO WEIGHT	P.V.P. € PRICE €
2094 10	2 1/2"	21.333	319,00
2094 11	3"	26.667	364,89
2094 12	4"	33.314	459,48
2094 13	5"	48.027	654,41
2094 14	6"	58.951	743,40
2094 16	8"	93.95	1179,56
2094 18	10"	138.138	1693,97
2094 20	12"	185.167	2351,41

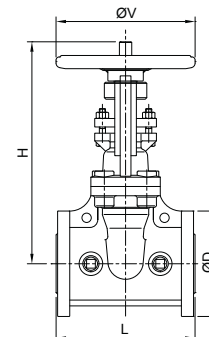

Información técnica
Technical information

Ref. 2100 - 2100D



Válvula de compuerta cierre de EPDM – Extremos ranurados
Const. Cuerpo y bonete de fundición nodular GGG.40. Diseño según AWWA C515. Ranurado según AWWA C606. Distancia entre caras según ASME B16.10. Husillo ascendente. Presión de trabajo 300 PSI. Temp. de trabajo: 0°C +80°C.
Certificación UL/FM.

Gate valve with EPDM seat – Groove ends

Body and bonnet made of ductile iron GGG.40. Design according to AWWA C515. Grooved standard AWWA C606. Face to face according to ASME B16.10. Rising stem (OS&Y). Working pressure 300 PSI. Working temperature: 0°C +80°C.
UL/FM certification.

MED.	L	D	E	F	G	H	V
2 1/2"	190	73	69,1	15,9	7,9	370	190
3"	203	88,9	84,9	15,9	7,9	420	256
4"	229	114,3	110,1	15,9	9,5	447	256
5"	254	141,3	137	15,9	9,5	547	310
6"	267	168,3	164	15,9	9,5	607	310
8"	292	219,1	214,4	19	11,1	754	355
10"	330	273	268,3	19	12,7	890	446
12"	356	323,9	318,3	19	12,7	1031	446
DN 65	190	76,1	72,3	15,9	7,9	370	190
DN 125	254	139,7	135,5	15,9	9,5	547	310
DN 150	267	165,1	160,9	15,9	9,5	607	310

2100 10	2 1/2"	16.2	306,25
2100 11	3"	20.2	350,30
2100 12	4"	25.3	441,10
2100 13	5"	38.5	628,24
2100 14	6"	44.8	713,67
2100 16	8"	73	1132,38
2100 18	10"	107.733	1626,23
2100 20	12"	151	2257,34

2100D 10	DN 65	15.76	306,25
2100D 13	DN 125	40	628,24
2100D 14	DN 150	47.7	713,67

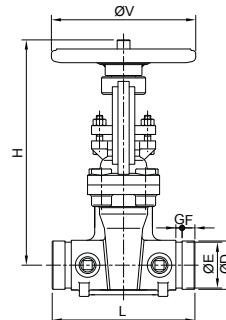

Información técnica
Technical information

Ref.2403E **NEW**



Válvula de retención oscilante - Extremos bridados.

Construcción cuerpo y tapa de fundición nodular GGG.40. Asiento EPDM. Diseño según AWWA C508. Bridas ASME B16.42. Presión de trabajo 350 PSI. Temp. de trabajo: 0°C +80°C.
Certificación UL/FM.

Flanged end Swing Check Valve

Body and cap made of ductile iron GGG.40. EPDM seat. Design according to AWWA C508. Flanged ends standard ASME B16.42. Working pressure 350 PSI. Working temperature: 0°C +80°C.
UL/FM certification.

MED.	A	D	L
2"	70	152	169
2 1/2"	78,5	178	181
3"	92	191	198
4"	105	229	214
5"	118	254	248
6"	130	280	270
8"	152	343	325
10"	235	406	457
12"	258	483	535

2403E 09	2"	2.8	-	127,24
2403E 10	2 1/2"	4.6	-	195,35
2403E 11	3"	6.2	-	243,74
2403E 12	4"	8.9	-	310,05
2403E 13	5"	14.3	-	422,95
2403E 14	6"	20.3	-	534,07
2403E 16	8"	35.7	-	808,27
2403E 18	10"	55	-	1127,04
2403E 20	12"	78.8	-	1367,23

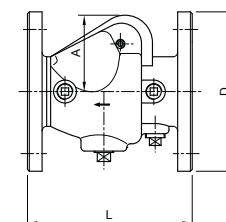

Información técnica
Technical information

Ref.2105



Tipo Wafer. Válvula esfera paso total 1 pieza montaje entre bridas PN 16

Cuerpo acero carbono A-105 bola eje y tapa: inox. AISI 304.
Asientos y juntas: PTFE. Temp. -20°C +180°C.
Mando manual por palanca.

Wafer type. 1 pc full bore ball valve mounting between flanges PN 16

Body: carbon steel A-105. Ball, stem and cover: stainless steel AISI 304.
Seats and seals: PTFE. Temp. -20°C +180°C.
Manually operated by handle.

DN	D	A	L	M
25	110	90	45	180
32	130	110	54	270
40	140	110	65	280
50	150	125	72	280
65	170	150	98	360
80	190	160	118	360
100	220	180	140	470

CÓDIGO CODE	MEDIDA SIZE	PESO WEIGHT	CAJA / BOX CARTON	P.V.P. € PRICE €
2105 06	1"	2.75		124,89
2105 07	1 1/4"	4.64		159,91
2105 08	1 1/2"	6.5		196,30
2105 09	2"	8.32		248,72
2105 10	2 1/2"	15.5		419,76
2105 11	3"	20.46		530,15
2105 12	4"	30		808,44

CÓDIGO CODE	MEDIDA SIZE	PESO WEIGHT	P.V.P. € PRICE €
2105 06	1"	2.75	124,89
2105 07	1 1/4"	4.64	159,91
2105 08	1 1/2"	6.5	196,30
2105 09	2"	8.32	248,72
2105 10	2 1/2"	15.5	419,76
2105 11	3"	20.46	530,15
2105 12	4"	30	808,44

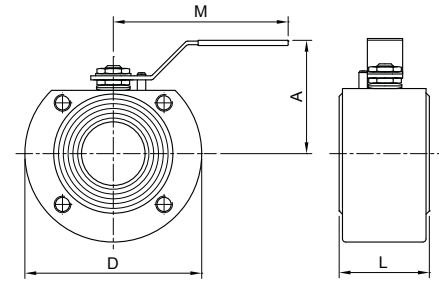

Información técnica
Technical information

Ref.2110



Tipo Wafer. Válvula esfera paso total 1 pieza montaje entre bridas PN 16

Cuerpo bola y eje: inox. AISI 316.
Asientos y juntas: PTFE Temp. -20°C +180°C.
Mando manual por palanca.

Wafer type. 1 pc full bore ball valve mounting between flanges PN 16

Body ball and stem: stainless steel AISI 316.
Seats and seals: PTFE Temp. -20°C +180°C.
Manually operated by handle.

DN	D	A	L	M
15	90	90	32	130
20	100	90	42	180
25	110	90	45	180
32	130	110	54	270
40	140	110	65	280
50	150	125	72	280
65	170	150	98	360
80	190	160	118	360
100	220	180	140	470

2110 04	1/2"	1.5	187,67
2110 05	3/4"	2.181	231,35
2110 06	1"	3	275,17
2110 07	1 1/4"	5	382,25
2110 08	1 1/2"	6.46	436,30
2110 09	2"	5.82	548,85
2110 10	2 1/2"	16	910,47
2110 11	3"	21.12	1215,18
2110 12	4"	30	1927,24

2110 04	1/2"	1.5	187,67
2110 05	3/4"	2.181	231,35
2110 06	1"	3	275,17
2110 07	1 1/4"	5	382,25
2110 08	1 1/2"	6.46	436,30
2110 09	2"	5.82	548,85
2110 10	2 1/2"	16	910,47
2110 11	3"	21.12	1215,18
2110 12	4"	30	1927,24

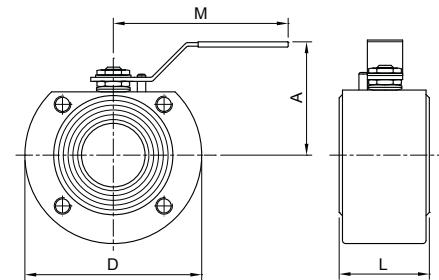

Información técnica
Technical information

Ref.2115



Tipo wafer. Válvula esfera paso total 1 pieza con cámara de calefacción montaje entre bridas PN 16

Cuerpo: acero al carbono forjado A-105. bola, eje y tapa: inox. AISI 304
asientos y juntas: PTFE. Temp. -20°C +180°C. Mando manual por palanca.

Wafer type. 1 pc full bore ball valve with heating chamber mounting between flanges PN 16

Body: forged carbon steel A-105. Ball stem and cover: stainless steel AISI 304.
Seats and seals: PTFE Temp. -20°C +180°C. Manually operated by handle.

DN	L	d
25	170	3/4"
32	190	3/4"
40	200	3/4"
50	210	3/4"
65	235	3/4"
80	250	3/4"
100	270	3/4"

2115 06	1"	2.95	264,46
2115 07	1 1/4"	5	327,94
2115 08	1 1/2"	6.5	401,21
2115 09	2"	8	454,16
2115 10	2 1/2"	16	718,09
2115 11	3"	19.76	855,08
2115 12	4"	30	1170,79

2115 06	1"	2.95	264,46
2115 07	1 1/4"	5	327,94
2115 08	1 1/2"	6.5	401,21
2115 09	2"	8	454,16
2115 10	2 1/2"	16	718,09
2115 11	3"	19.76	855,08
2115 12	4"	30	1170,79

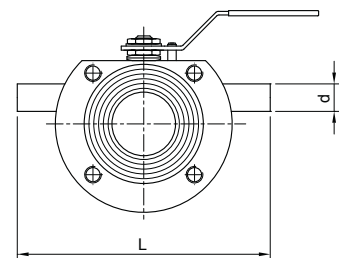

Información técnica
Technical information

Ref.2118



Tipo Wafer. Válvula esfera paso total 1 pieza montaje entre bridas PN 16

Const. acero inox CF8M (316) microfusión. Esfera y eje inoxidable 316. Asientos PTFE + 15% FV. PN 16. Temp. -25°C +180°C. Montaje directo S/ISO 5211. Mando manual por palanca con sistema de bloqueo.

Wafer type. 1 pc full bore ball valve mounting between flanges PN 16

Const. stainless steel CF8M (316) investment casting. Ball and stem: stainless steel 316. Seats: PTFE + 15% GF. PN 16. Temp. -25°C +180°C. Direct assembling ISO 5211. Manually operated by handle with locking system.

MED.	DN	L	M	D	H	n x d
1/2"	15	36	120	95	89	4 x M12
3/4"	20	38	120	105	94	4 x M12
1"	25	50	160	115	90	4 x M12
1 1/4"	32	53	160	140	100	4 x M16
1 1/2"	40	65	200	150	105	4 x M16
2"	50	78	200	165	125	4 x M16
2 1/2"	65	98	255	185	140	4 x M16
3"	80	118	255	200	145	8 x M16
4"	100	140	300	220	175	8 x M16



Información técnica
Technical information

CÓDIGO CODE	MEDIDA SIZE	PESO WEIGHT	P.V.P. € PRICE €
2118 04	1/2"	1.23	93,51
2118 05	3/4"	1.556	113,78
2118 06	1"	2.301	138,36
2118 07	1 1/4"	3.482	202,96
2118 08	1 1/2"	4.583	257,93
2118 09	2"	6.155	336,04
2118 10	2 1/2"	9.72	525,48
2118 11	3"	13.663	712,50
2118 12	4"	19.398	996,47

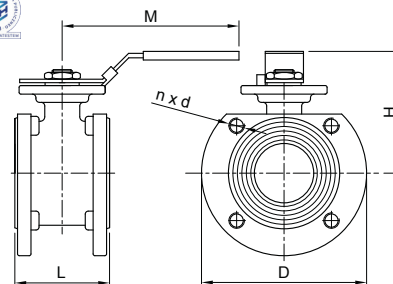

Ref.2119



Válvula esfera Paso Total 1 pieza con cámara de calefacción. Montaje entre bridas PN 16

Const. acero inox CF8M (316) Microfusión. Esfera y eje inoxidable 316. Asientos PTFE + 15% FV. PN 16. Temp. -25 °C +180 °C. Montaje directo s/ ISO 5211. Mando manual por palanca con sistema de bloqueo.

Wafer type - 1 Pc full bore ball valve with heating chamber. Mounting between flanges PN 16

Const. stainless steel CF8M (316) Investment casting. Ball and stem: stainless steel 316. Seats: PTFE + 15% GF. PN 16. Temp. -25 °C +180 °C. Direct assembling ISO 5211. Manually operated by handle with locking system.

MED.	DN	L	d
1/2"	15	150	Rp 3/4"
3/4"	20	160	Rp 3/4"
1"	25	170	Rp 3/4"
1 1/4"	32	190	Rp 3/4"
1 1/2"	40	200	Rp 3/4"
2"	50	210	Rp 3/4"
2 1/2"	65	235	Rp 3/4"
3"	80	250	Rp 3/4"
4"	100	270	Rp 3/4"



Información técnica
Technical information

2119 04	1/2"	1.52	213,07
2119 05	3/4"	1.85	269,03
2119 06	1"	2.675	266,12
2119 07	1 1/4"	3.95	328,26
2119 08	1 1/2"	5.21	457,37
2119 09	2"	6.945	574,04
2119 10	2 1/2"	10.89	752,27
2119 11	3"	15.538	1014,59
2119 12	4"	21.8	1370,16

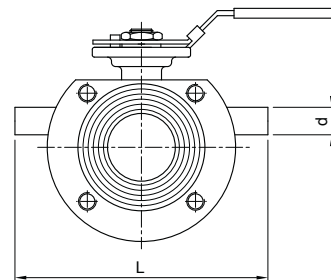

Ref. 2220 - 2220N



Válvula de compuerta PN-16

Rosca BSP, también disponible con rosca NPT (2220N).
 Construcción: inox. CF8M (316) microfundición.
 Juntas: PTFE. Conexión: rosca ISO 7-1 (EN 10226-1). Presión máx.: 16BAR a 120°C - 10 BAR a 180°C. Temp. mín. -30°C.

Gate valve PN-16

BSP thread, also available NPT thread (2220N).
 Constr. stainless steel CF8M (316) investment casting.
 Gasket: PTFE: threaded ends ISO 7-1 (EN 10226-1).
 Max. pressure: 16 BAR at 120°C - 10 BAR at 180°C.
 Minimum temp.: -30°C.

R	DN	A	L	V
1/2"	15	100	55	70
3/4"	20	110	61	70
1"	25	115	68	70
1 1/4"	32	130	77	80
1 1/2"	40	150	80	100
2"	50	167	93	100

CÓDIGO CODE	MEDIDA SIZE	PESO WEIGHT	P.V.P. € PRICE €
2220 04	1/2"	0.414	65,59
2220 05	3/4"	0.553	81,61
2220 06	1"	0.695	100,86
2220 07	1 1/4"	1.089	125,96
2220 08	1 1/2"	1.524	175,85
2220 09	2"	2.147	211,07

Precios rosca NPT a consultar / NPT thread prices on request

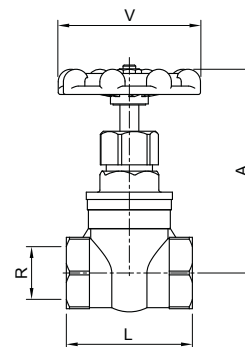

Información técnica
 Technical information

Ref. 2221 - 2222

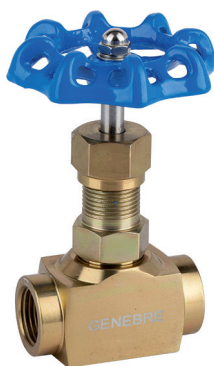

Válvulas de aguja - 3000 Lbs
Art. 2221. Rosca gas ISO 228-1 H/H. Art. 2222. Rosca NPT H/H

Construcción: acero A105 / aguja INOX A182 F316 + T. Térmico. Estopada: PTFE Presión máxima de trabajo 210 bar. Temperatura de trabajo -20°C a 250°C.

Needle valve - 3000 Lbs
Art. 2221. Gas thread ISO 228-1 F/F. Art. 2222. NPT thread F/F

Constr. steel A105, needle stainless steel A182 F316 + Heat Treatment. Stem packing: PTFE Max. working pressure 210 bar. Working temperature -20°C to 250°C.

MED.	E	H	L	K
1/4"	25	85	50	3
3/8"	30	100	55	4
1/2"	34	115	60	6
3/4"	40	120	70	8
1"	45	138	75	9
1 1/4"	57	165	90	11
1 1/2"	67	185	100	15
2"	78	195	120	18

2221 02	1/4"	0.317	28,54
2221 03	3/8"	0.408	28,66
2221 04	1/2"	0.552	32,58
2221 05	3/4"	0.813	41,09
2221 06	1"	1.013	59,84
2221 07	1 1/4"	1.945	103,95
2221 08	1 1/2"	2.803	147,60
2221 09	2"	4.749	208,04

Precios rosca NPT a consultar / NPT thread prices on request

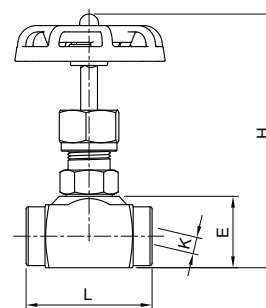

Información técnica
 Technical information

Ref. 2223 - 2224



Válvulas de aguja - 3000 Lbs
Art. 2223. Rosca gas ISO 228-1 H/H. Art. 2224. Rosca NPT H/H

Construcción: acero inoxidable A182 F316/aguja inox A182 F316 + T. térmico. Estopada: PTFE. Presión máxima de trabajo 210 bar. Temperatura de trabajo: -20°C a 250°C.

Needle valve - 3000 Lbs
Art. 2223. Gas thread ISO 228-1 F/F. Art. 2224. NPT thread F/F

Construction: stainless steel A182 F316/needle stainless steel A182 F316 + heat treatment. Stem packing PTFE. Max. working pressure 210 bar. Working temperature -20°C to 250°C.

MED.	E	H	L	K
1/4"	25	85	50	3
3/8"	30	100	55	4
1/2"	34	115	60	6
3/4"	40	120	70	8
1"	45	138	75	9
1 1/4"	57	165	90	11
1 1/2"	67	185	100	15
2"	78	195	120	18

2223 02	1/4"	0.319	51,83
2223 03	3/8"	0.415	58,58
2223 04	1/2"	0.564	66,40
2223 05	3/4"	0.822	90,95
2223 06	1"	1.031	129,83
2223 07	1 1/4"	1.915	246,71
2223 08	1 1/2"	2.803	321,86
2223 09	2"	4.749	396,13

Precios rosca NPT a consultar / NPT thread prices on request

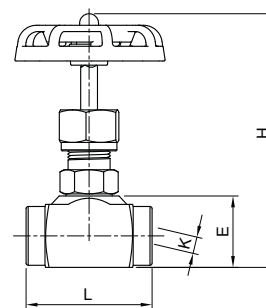

Información técnica
 Technical information

Ref. 2225 - 2225N

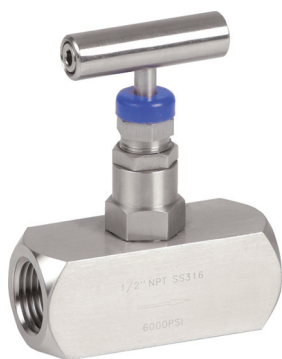

Válvula de aguja – 6000 Lbs

También disponible con rosca NPT (2225N).
Construcción: Acero inox. A182 F316 / Aguja inox A182 F316 + T. Térmico.
Rosca ISO 228-1. Estopada PTFE. Presión máxima de trabajo 410 bar.
Temperatura de trabajo -54°C a 250°C.

Needle valve – 6000 Lbs

Also available with NPT thread (2225N).
Construction: Stainless steel A182 F316 / Needle stainless steel A182 F316 + Heat treatment. Thread ISO 228-1. Stem packing PTFE. Max. working pressure 410 bar. Working temperature -54°C to 250°C.

MED.	E	H	L	M	K
1/4"	25,5	90	61	55	4
3/8"	25,5	90	61	55	4
1/2"	28,5	92	68	55	5
3/4"	38	98	76	55	6
1"	44,5	108	85	55	8

CÓDIGO CODE	MEDIDA SIZE	PESO WEIGHT	P.V.P. € PRICE €
2225 02	1/4"	0.38	64,32
2225 03	3/8"	0.364	70,75
2225 04	1/2"	0.436	73,95
2225 05	3/4"	0.792	105,42
2225 06	1"	1.118	145,01

Precios rosca NPT a consultar / NPT thread prices on request

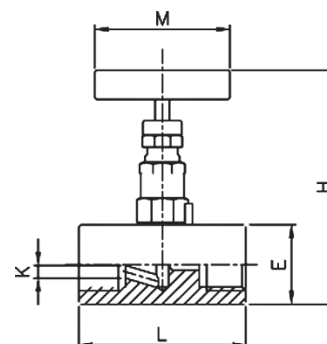

Información técnica
Technical information

Ref. 2226 - 2226N



Válvula de aguja – 6000 lbs con purga

También disponible con rosca NPT (2226N).
Construcción: Acero inox. A182 F316 / Aguja inox A182 F316 + T. térmico.
Rosca ISO 7-1. Estopada PTFE. Presión máxima de trabajo 410 bar.
Temperatura de trabajo -54°C a 250°C.

Needle valve – 6000 lbs with vent port

Also available with NPT thread (2226N).
Construction: Stainless steel A182 F316 / Needle stainless steel A182 F316 + Heat treatment. Thread ISO 7-1. Stem packing ptfe. Max. working pressure 410 bar. Working temperature -54°C to 250°C.

MED.	E	H	L	M	K
1/4"	32	90	82	55	4
1/2"	32	90	89	55	5

CÓDIGO CODE	MEDIDA SIZE	PESO WEIGHT	P.V.P. € PRICE €
2226 02	1/4"	0.538	86,01
2226 04	1/2"	0.567	90,98

Precios rosca NPT a consultar / NPT thread prices on request

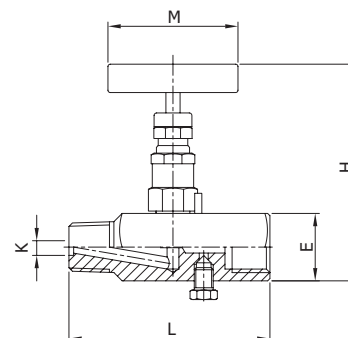

Información técnica
Technical information

Ref. 2227 - 2227N **NEW**



Válvula de aguja – 10.000 Lbs

También disponible con rosca NPT (2227N).
Construcción: Acero inox. A182 F316 / Aguja inox A182 F316 + T. Térmico.
Rosca ISO 228-1. Estopada PTFE. Presión máxima de trabajo 410 bar.
Temperatura de trabajo -54°C a 250°C.

Needle valve – 10.000 Lbs

Also available with NPT (2227N).
Construction: Stainless steel A182 F316 / Needle stainless steel A182 F316 + Heat treatment. Thread ISO 228-1. Stem packing PTFE. Max. working pressure 410 bar. Working temperature -54°C to 250°C.

MED.	E	H	L	M	K
1/4"	25,5	90	61	55	4
3/8"	25,5	90	61	55	4
1/2"	28,5	92	68	55	5
3/4"	38	98	76	55	6
1"	44,5	108	85	55	8

CÓDIGO CODE	MEDIDA SIZE	PESO WEIGHT	CAJA / BOX CARTON	P.V.P. € PRICE €
2227 02	1/4"	0.35	20-60	82,70
2227 03	3/8"	0.35	20-60	82,70
2227 04	1/2"	0.45	15-45	93,21
2227 05	3/4"	1.15	7-21	127,43
2227 06	1"	1.33	6-18	151,46

Precios rosca NPT a consultar / NPT thread prices on request

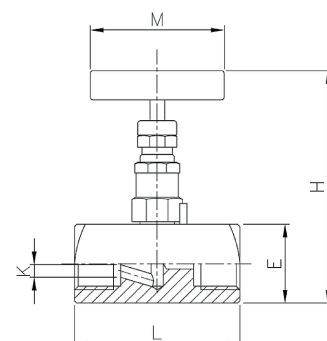

Información técnica
Technical information

Ref. 2230 - 2230N



Válvula de globo PN 16

Rosca BSP, también disponible en rosca NPT (2230N).
Construcción: inox. CF8M (316) microfundición.
Juntas: PTFE conexión: rosca ISO 7-1 (EN 10226-1).
Presión máx.: 16 BAR a 120°C 10 BAR a 180°C.

Globe valve PN 16

BSP thread, also available NPT thread (2230N).
Constr. stainless steel CF8M (316) investment casting.
Seals: PTFE; threaded ends ISO 7-1 (EN 10226-1).
Max. pressure: 16 BAR at 120°C - 10 BAR at 180°C.

R	DN	A	L	V
1/2"	15	97	65	70
3/4"	20	103	75	70
1"	25	116	90	80
1 1/4"	32	135	105	80
1 1/2"	40	152	120	100
2"	50	164	140	100

CÓDIGO CODE	MEDIDA SIZE	PESO WEIGHT	P.V.P. € PRICE €
----------------	----------------	----------------	---------------------

2230 04	1/2"	0.441	50,51
2230 05	3/4"	0.657	60,97
2230 06	1"	0.838	80,30
2230 07	1 1/4"	1.17	107,04
2230 08	1 1/2"	1.751	143,63
2230 09	2"	2.45	188,24

Precios rosca NPT a consultar / NPT thread prices on request

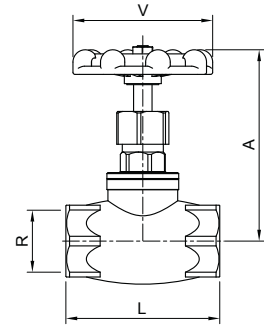

Información técnica
Technical information

Ref. 2228



Válvula de equilibrado estático - Bridas DIN PN 16

Const. cuerpo y bonete fundición nodular GGG-40. Eje acero inoxidable.
Cierre en EPDM. Orificio variable. Doble regulación. Temperatura de trabajo
-10°C +120°C.

Static balancing valve - Flanged ends DIN PN 16

Body and bonnet of ductil iron GGG-40. Stainless steel stem. Sealing: EPDM.
Variable orifice. Double regulation. Working temperature -10°C +120°C.

MED.	DN	D	L	A	V
2"	50	165	230	276	180
2 1/2"	65	185	290	308	180
3"	80	200	310	320	180
4"	100	220	350	340	180
5"	125	250	400	375	180
6"	150	285	480	410	180
8"	200	340	600	550	350
10"	250	405	730	590	350
12"	300	460	850	678	450

2228 09	2"	11.75	378,11
2228 10	2 1/2"	16.058	415,59
2228 11	3"	19.396	504,37
2228 12	4"	26.129	632,79
2228 13	5"	40.333	894,21
2228 14	6"	54.1	1198,84
2228 16	8"	104.724	2155,14
2228 18	10"	149.375	3429,85
2228 20	12"	215.056	4850,43

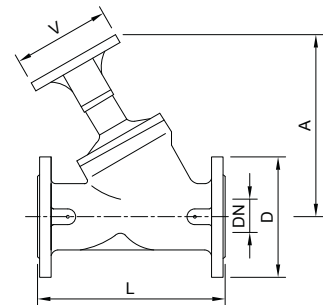

Información técnica
Technical information

Ref. 3073



Válvula de equilibrado estático

PN 20. Construcción cuerpo y componentes internos en latón. Juntas
VITON. Extremos rosca gas (BSP) H-H, ISO 228/1. Toma de presión G 1/8" H.
Temperatura trabajo de -30°C a 120°C.

Static balancing valve

PN 20. Brass construction of body and inner components. Gas threaded
ends (BSP) F-F, ISO 228/1. Pressure taps connection G 1/8" F. Working
temperature from -30°C to 120°C.

R	A	B	C	D
1/2"	84	15	96	22
3/4"	85,6	17,8	97	21,5
1"	98	21,3	103,3	29,5
1 1/4"	101	28	111	29
1 1/2"	107	31	120	27
2"	115	37	132	21,9

3073 04	1/2"	0.415	57,20
3073 05	3/4"	0.437	59,61
3073 06	1"	0.675	75,73
3073 07	1 1/4"	0.93	84,75
3073 08	1 1/2"	1.18	120,24
3073 09	2"	1.55	183,64

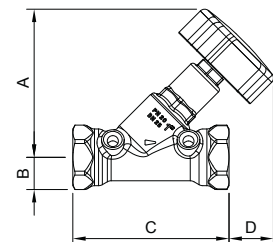

Información técnica
Technical information

Ref.2231



Válvula de globo con fuelle – Bidas DIN PN 16

Const. cuerpo y bonete acero al carbono GS-C25 (WCB). Material del fuelle: inoxidable 304. Junta y empaquetadura de grafito. Material de cierre: inoxidable. Temperatura máxima de trabajo 350°C.

Bellow globe valve – Flanged ends DIN PN 16

Body and bonnet made of carbon steel GS-C25 (WCB). Bellow material: stainless steel 304. Gasket and packing: graphite. Seal material: stainless steel. Max. working temperature 350°C.

MED.	DN	A	D	L	V
1/2"	15	195	95	130	140
3/4"	20	200	105	150	140
1"	25	220	115	160	160
1 1/4"	32	225	140	180	160
1 1/2"	40	235	150	200	180
2"	50	250	165	230	180
2 1/2"	65	260	185	290	220
3"	80	265	200	310	250
4"	100	370	220	350	300
5"	125	400	250	400	350
6"	150	515	285	480	400
8"	200	550	340	600	500



Información técnica
Technical information

CÓDIGO CODE	MEDIDA SIZE	PESO WEIGHT	P.V.P. € PRICE €
2231 04	1/2"	4.233	147,33
2231 05	3/4"	5	152,30
2231 06	1"	6	171,35
2231 07	1 1/4"	7.5	218,97
2231 08	1 1/2"	10	257,03
2231 09	2"	12.55	304,63
2231 10	2 1/2"	15.6	456,97
2231 11	3"	20.55	571,19
2231 12	4"	36.967	761,57
2231 13	5"	53.5	1009,19
2231 14	6"	81.7	1380,42
2231 16	8"	131.033	2237,22

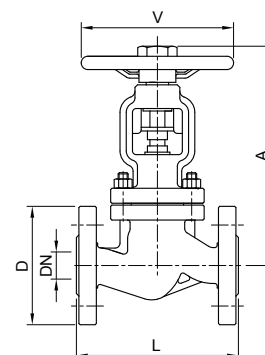

Ref.2229A

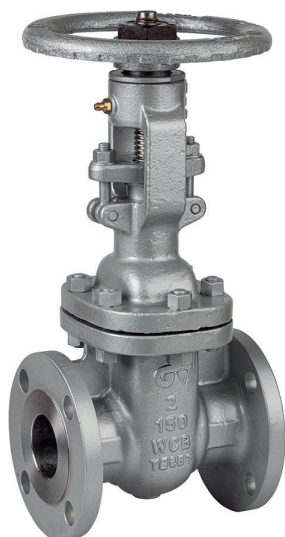

Válvula de compuerta con bridas ANSI clase 150

Const. Cuerpo y bonete acero al carbono ASTM A216 WCB. Diseño según API 600. Compuerta: ASTM A216 WCB + 13 Cr. Distancia entre bridas según ASME B16.10. Bidas según ASME B16.5. Temp. de trabajo: -20°C +425°C.

Gate valve with flanged ends ANSI 150 class

Body and bonnet made of carbon steel ASTM A216 WCB. Design according to API 600. Gate: ASTM a216 WCB + 13 Cr. Face to face according to ASME B16.10. Flanged ends according to ASME B16.5. Working temperature: -20°C +425°C.

MED	DN	D	L	A	M
2"	50	150	178	405	200
2 1/2"	65	180	190	455	200
3"	80	190	203	505	250
4"	100	230	229	585	250
5"	125	255	254	680	300
6"	150	280	267	785	300
8"	200	345	292	955	350
10"	250	405	330	1175	400
12"	300	485	356	1365	450



Información técnica
Technical information

2229A 09	2"	18	281,12
2229A 10	2 1/2"	24	386,01
2229A 11	3"	29.9	465,73
2229A 12	4"	43.9	654,54
2229A 13	5"	56	839,15
2229A 14	6"	68	1032,16
2229A 16	8"	108.2	1468,51
2229A 18	10"	179.286	2365,84
2229A 20	12"	252.6	3239,28

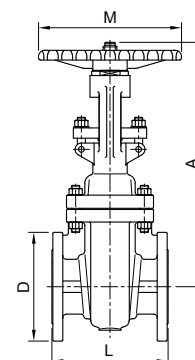

Ref.2232N - 2232S



Válvula de compuerta clase 800 rosca NPT

Const. cuerpo y bonete acero forjado ASTM A105N. Material de cierre: asiento con stellite. Compuerta: ASTM A182 - F6a. (trim #8/XU). Bonete atornillado. Extremos roscados NPT.

Gate valve class 800 NPT thread ends

Body and bonnet made of forged steel ASTM A105N. Seat material: stainless steel stellited. Gate: astm a182 F6a (trim #8/XU). Bolted bonnet. NPT. Thread ends. (2232S- socket weld ends).

Max. working pressure: 140bar/ 2000 Psi

Max. working temperature: 420°C / 788°F

MED.	DN	d	SW	H	W	L
1/2"	15	10	21,8	151	100	79
3/4"	20	13,5	27,1	158	100	92
1"	25	18	33,8	185	125	111
1 1/4"	32	24	42,6	239	160	120
1 1/2"	40	30	48,7	243	160	120
2"	50	36,5	61,1	279	180	140

CÓDIGO CODE	MEDIDA SIZE	PESO WEIGHT	P.V.P. € PRICE €
2232N 04	1/2"	2.191	70,07
2232N 05	3/4"	2.31	78,47
2232N 06	1"	4.065	97,65
2232N 07	1 1/4"	5.78	141,14
2232N 08	1 1/2"	6.582	182,49
2232N 09	2"	10.023	269,59
2232S 04	1/2"	2.175	70,07
2232S 05	3/4"	2.335	78,47
2232S 06	1"	4.025	97,65
2232S 07	1 1/4"	5.522	141,14
2232S 08	1 1/2"	6.675	182,49
2232S 09	2"	10.095	269,59

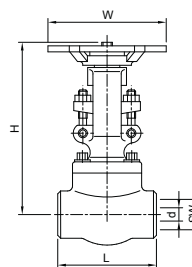

Información técnica
Technical information

Ref.2232A



Válvula de compuerta con bridas ANSI clase 150

Const. cuerpo y bonete acero forjado ASTM A105N. Material de cierre: asiento con stellite. Compuerta: ASTM A182 - F6a. (Trim #8/XU). Bonete atornillado.

Gate valve with flanged ends ANSI 150 class

Body and bonnet made of forged steel ASTM A105N. Seat material: stainless steel stellited. Gate: ASTM A182 F6a (Trim #8/XU). Bolted bonnet.

Max. working pressure: 19bar/ 275 Psi

Max. working temperature: 420°C / 788°F

MED.	DN	A	D	L	V
1/2"	15	157	90	108	80
3/4"	20	163	100	117	80
1"	25	194	110	127	105
1 1/4"	32	196	115	140	140
1 1/2"	40	217	125	165	140
2"	50	251	150	178	160

2232A 04	1/2"	2.78	92,72
2232A 05	3/4"	3.47	103,95
2232A 06	1"	5.143	151,71
2232A 07	1 1/4"	7.64	191,04
2232A 08	1 1/2"	9.88	258,46
2232A 09	2"	15.098	353,98

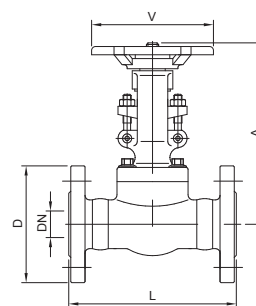

Información técnica
Technical information

Ref.2233N - 2233S



Válvula de globo clase 800 rosca NPT

Const. cuerpo y bonete acero forjado ASTM A105N. Material de cierre: asiento con stellite. Disco: ASTM A182 - F6a. (trim #8/XU). Bonete atornillado. Extremos roscados NPT.

Globe valve class 800 NPT thread ends

Body and bonnet made of forged steel ASTM A105N. Seat material: stainless steel stellited. Disc: ASTM A182. F6a (trim #8/XU). Bolted bonnet. NPT thread ends.

Max. working pressure: 140bar/ 2000 Psi

Max. working temperature: 420°C / 788°F

MED.	DN	d	SW	H	W	L
1/2"	15	10	21,8	164	100	79
3/4"	20	13	27,1	164	100	92
1"	25	17	33,8	203	125	111
1 1/4"	32	23	42,6	224	160	120
1 1/2"	40	28	48,7	260	160	152
2"	50	36	61,1	300	180	172

2233N 04	1/2"	2.19	68,70
2233N 05	3/4"	2.312	76,95
2233N 06	1"	3.92	95,73
2233N 07	1 1/4"	5.252	138,37
2233N 08	1 1/2"	7.332	178,90
2233N 09	2"	11.913	264,32
2233S 04	1/2"	2.228	68,70
2233S 05	3/4"	2.36	76,95
2233S 06	1"	3.914	95,73
2233S 07	1 1/4"	5.735	138,37
2233S 08	1 1/2"	7.703	178,90
2233S 09	2"	11.64	264,32

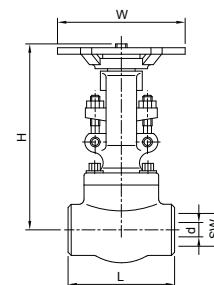

Información técnica
Technical information

Ref.2233A



Válvula de globo con bridas ANSI clase 150

Const. cuerpo y bonete acero forjado ASTM A105N. Material de cierre: asiento con stellite. Compuerta: ASTM A182 - F6a. (Trim #8/XU). Bonete atornillado.

Globe valve with flanged ends ANSI 150 class

Body and bonnet made of forged steel ASTM A105N. Seat material: stainless steel stellited. Gate: ASTM A182 F6a (Trim #8/XU). Bolted bonnet.

MED.	DN	A	D	L	V
1/2"	15	185	90	108	80
3/4"	20	183	100	117	80
1"	25	218	110	127	105
1 1/4"	32	223	115	140	140
1 1/2"	40	245	125	165	140
2"	50	269	150	203	160

CÓDIGO CODE	MEDIDA SIZE	PESO WEIGHT	P.V.P. € PRICE €
2233A 04	1/2"	2.862	92,72
2233A 05	3/4"	3.595	103,95
2233A 06	1"	5.345	151,71
2233A 07	1 1/4"	7.848	191,04
2233A 08	1 1/2"	10.523	269,70
2233A 09	2"	16.41	376,46

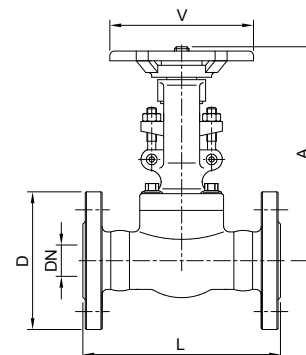

Información técnica
Technical information

Ref. 2234N - 2234S



Válvula de retención clase 800 tipo pistón - Extremos rosca NPT

Const. cuerpo y tapa acero forjado ASTM A105N. Material de cierre: asiento con stellite. Pistón: ASTM A182 - F6a. (trim #8/XU). Tapa atornillada. Extremos roscados NPT. (ref. 2234S - extremos S.W.)

Check valve class 800. Piston type. NPT thread ends

Body and cover made of forged steel ASTM A105N. Seat material: stainless steel stellited. Piston: ASTM A182 F6a (trim #8/XU). Bolted cover. NPT thread ends. (ref 2234S - S-W ends)

MED.	DN	SW	H	L
1/2"	15	21,8	61	79
3/4"	20	27,1	61	92
1"	25	33,8	78	111
1 1/4"	32	42,6	84	120
1 1/2"	40	48,7	101	120
2"	50	61,1	120	140

2234N 04	1/2"	1.55	66,46
2234N 05	3/4"	1.69	74,43
2234N 06	1"	2.815	95,63
2234N 07	1 1/4"	4.108	138,22
2234N 08	1 1/2"	6.2	178,72
2234N 09	2"	9.845	264,05
2234S 04	1/2"	1.52	66,46
2234S 05	3/4"	1.653	74,43
2234S 06	1"	2.858	95,63
2234S 07	1 1/4"	4.174	138,22
2234S 08	1 1/2"	6.295	178,72
2234S 09	2"	9.9	264,05

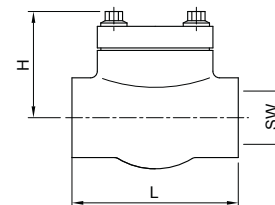

Información técnica
Technical information

Ref.2240



Mirillas de turbulencia doble cristal

Construcción: cuerpo inox. CF8M (316). Extremos rosca ISO 7-1 (EN 10226-1). Vidrio: normal con tratamiento térmico. Bajo demanda: vidrio borosilicato (2240P). Presión máx. de trabajo: 16 BAR. Temp. máx. de trabajo: 160°C.

Sight glass, double glass

Constr. body stainless steel CF8M (316). ISO 7-1 (EN 10226-1) threaded ends. Glass: normal with thermal treatment. On request: borosilicate glass (2240P). Max. working pressure: 16 BAR. Max. working temp.: 160°C.

DN	L	A	B	C
15	100	70	64	40
20	100	70	64	40
25	120	88	72	50
32	120	88	72	50
40	150	123	96	65
50	150	123	96	65

2240 04	1/2"	1.16	99,56
2240 05	3/4"	1.06	111,63
2240 06	1"	1.569	126,23
2240 07	1 1/4"	1.618	158,85
2240 08	1 1/2"	3.884	246,99
2240 09	2"	3.897	293,50

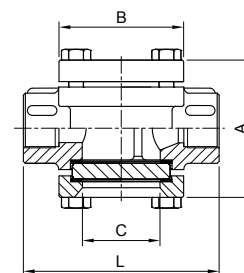

Información técnica
Technical information

Ref.2250



Mirillas de turbulencia doble cristal bridas DIN

Construcción: cuerpo inox. CF8M (316). Extremos bridas DIN PN 16. Vidrio: normal con tratamiento térmico. Bajo demanda: vidrio "borosilicato" (2250P). Presión máx. de trabajo: 16 BAR. Temp. máx. de trabajo: 160°C.

Sight glass, double glass DIN flanges

Constr. body stainless steel CF8M (316). Ends: flanges DIN PN 16. Glass: normal with thermal treatment on request: "borosilicate" glass (2250P). Max. working pressure: 16 BAR. Max. working temp.: 160°C.

DN	L	A	B
15	130	95	40
20	150	105	40
25	160	115	50
32	180	140	50
40	200	150	65
50	230	165	65
65	290	185	100
80	310	200	100
100	350	220	125

CÓDIGO CODE	MEDIDA SIZE	PESO WEIGHT	P.V.P. € PRICE €
2250 04	1/2"	2.211	161,27
2250 05	3/4"	2.783	186,66
2250 06	1"	3.648	232,88
2250 07	1 1/4"	5.008	290,83
2250 08	1 1/2"	6.908	389,60
2250 09	2"	8.576	473,45
2250 10	2 1/2"	14.556	784,78
2250 11	3"	16.807	987,33
2250 12	4"	24.659	1357,84

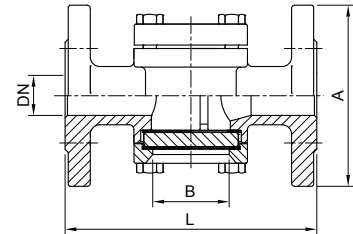

Información técnica
Technical information

Ref.2252 - 2252N



Válvula de Seguridad

Conexión rosca gas BSP M-H s/ ISO228/1, disponible con rosca NPT (2252N). Diseño, cálculo y control s/normas EN 12516 y EN 4126-1/7. Construcción: Acero Inoxidable 1.4408 (CF8M). Asiento y disco en acero inoxidable AISI 316. Tara entre 0,5 barg y 40 barg. Presión máxima de trabajo 40 bar. Temperatura de trabajo -20°C +300°C.

Aplicación: Gases o vapor

Safety Valve

BSP threaded ends acc./ISO 228/1 M-F, available with NPT threaded (2252N). Design, calculations and control according to EN 12516 and EN 4126-1/7. Construction: Stainless steel 1.4408 (CF8M). Seat and disc in stainless steel AISI 316. Set pressure between 0,5 barg and 40 barg. Max. working pressure 40 bar. Working temperature -20°C +300°C.

Applications: Gas or steam

MED.	PN	P	A	B	C	D
1/2" x 1"	40	13	59	129	35	45
3/4" x 1"	40	14	59	129	35	45
1" x 1"	40	16	59	129	35	45
1" x 1 1/4"	40	16	62	125	35	45
1 1/4" x 1 1/4"	40	20	65	125	35	45
1 1/2" x 2"	40	28	81	206	46	65
2" x 2"	40	32	83	206	46	65

2252 04 06	1/2" x 1"	1.675	220,30
2252 05 06	3/4" x 1"	1.78	226,67
2252 06 06	1" x 1"	1.628	234,02
2252 06 07	1" x 1 1/4"	1.49	262,14
2252 07 07	1 1/4" x 1 1/4"	1.535	266,61
2252 08 09	1 1/2" x 2"	3.71	465,42
2252 09 09	2" x 2"	3.78	472,75

Precios rosca NPT a consultar / NPT thread prices on request

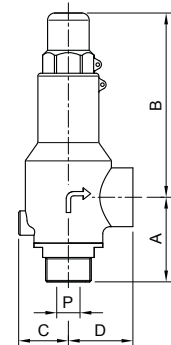

Información técnica
Technical information

Ref.2253 - 2253N



Válvula de Seguridad roscada con palanca

Conexión rosca gas BSP M-H s/ ISO228/1, disponible con rosca NPT (2253N). Diseño, cálculo y control s/normas EN 12516 y EN 4126-1/7. Construcción: Acero Inoxidable 1.4408 (CF8M). Asiento y disco en acero inoxidable AISI 316. Tara entre 0,5 barg y 40 barg. Presión máxima de trabajo 40 bar. Temperatura de trabajo -20°C +300°C. Palanca para abertura manual, caperuza abierta.

Aplicación: Gases o vapor

Stainless steel safety valve with threads and lifting lever

BSP threaded ends acc./ISO 228/1 M-F, available with NPT threaded (2253N). Design, calculations and control according to EN 12516 and EN 4126-1/7. Construction: Stainless steel 1.4408 (CF8M). Seat and disc in stainless steel AISI 316. Set pressure between 0,5 barg and 40 barg. Max. working pressure 40 bar. Working temperature -20°C +300°C. Lever for manual opening, open cap.

Applications: Gas or steam

MED.	PN	P	A	B	C	D	H1	H2
1/2" x 1"	40	13	59	144	35	45	50	137
3/4" x 1"	40	14	59	144	35	45	50	137
1" x 1"	40	16	59	144	35	45	50	137
1" x 1 1/4"	40	16	62	141	35	45	50	137
1 1/4" x 1 1/4"	40	20	65	141	35	45	50	137
1 1/2" x 2"	40	28	81	226	46	65	50	196
2" x 2"	40	32	83	226	46	65	50	196

2253 04 06	1/2" x 1"	1.96	259,18
2253 05 06	3/4" x 1"	1.36	263,42
2253 06 06	1" x 1"	1.36	270,77
2253 06 07	1" x 1 1/4"	1.49	298,90
2253 07 07	1 1/4" x 1 1/4"	2.14	303,37
2253 08 09	1 1/2" x 2"	3.82	519,97
2253 09 09	2" x 2"	3.89	527,40

Precios rosca NPT a consultar / NPT thread prices on request

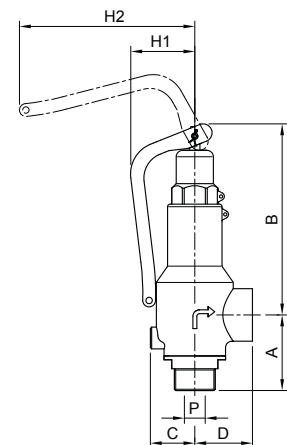

Información técnica
Technical information

Ref.2256



Válvula de Seguridad

Extremo bridado PN16/40 (entrada) según EN 1092-1 y rosca gas BSP s/ ISO228/1 (salida). Diseño, cálculo y control s/normas EN 12516 y EN 4126-1/7. Construcción: Acero Inoxidable 1.4408 (CF8M). Asiento y disco en acero inoxidable AISI 316. Tara entre 0,5 barg y 40 barg. Presión máxima de trabajo 40 bar. Temperatura de trabajo -20°C +300°C.

Aplicación: Gases o vapor.

Safety Valve

Flanged end PN16/40 (inlet) acc. to EN 1092-1 and threaded end BSP acc. to ISO 228/1 (outlet). Design, calculations and control according to EN 12516 and EN 4126-1/7. Construction: Stainless steel 1.4408 (CF8M). Seat and disc in stainless steel. AISI 316. Set pressure between 0,5 barg and 40 barg. Max. working pressure 40 bar. Working temperature -20°C +300°C.

Applications: Gas or steam

MED.	PN	P	A	B	C	D	G
DN15 x 1"	16/40	13	87	129	35	45	95
DN20 x 1"	16/40	14	88	129	35	45	105
DN25 x 1"	16/40	16	94	129	35	45	115
DN25 x 1 1/4"	16/40	16	98	125	35	45	115
DN32 x 1 1/4"	16/40	20	102	125	35	45	140
DN40 x 2"	16/40	28	126	206	46	65	150
DN50 x 2"	16/40	32	127	206	46	65	165

CÓDIGO CODE	MEDIDA SIZE	PESO WEIGHT	P.V.P. € PRICE €
2256 04 06	1/2" x 1"	2.18	280,07
2256 05 06	3/4" x 1"	2.52	300,68
2256 06 06	1" x 1"	2.84	321,35
2256 06 07	1" x 1 1/4"	2.98	383,42
2256 07 07	1 1/4" x 1 1/4"	3.9	421,92
2256 08 09	1 1/2" x 2"	6.4	677,04
2256 09 09	2" x 2"	7.31	728,11

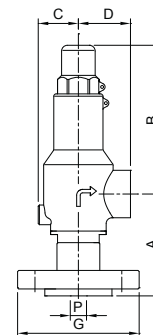

Información técnica
Technical information

Ref.2257



Válvula de Seguridad

Extremo bridado PN16/40 (entrada) según EN 1092-1 y rosca gas BSP s/ ISO228/1 (salida). Diseño, cálculo y control s/normas EN 12516 y EN 4126-1/7. Construcción: Acero Inoxidable 1.4408 (CF8M). Asiento y disco en acero inoxidable AISI 316. Tara entre 0,5 barg y 40 barg. Presión máxima de trabajo 40 bar. Temperatura de trabajo -20°C +300°C. Palanca para apertura manual, caperuza abierta.

Aplicación: Gases o vapor.

Safety Valve

Flanged end PN16/40 (inlet) acc. to EN 1092-1 and threaded end BSP acc. to ISO 228/1 (outlet). Design, calculations and control according to EN 12516 and EN 4126-1/7. Construction: Stainless steel 1.4408 (CF8M). Seat and disc in stainless steel. AISI 316. Set pressure between 0,5 barg and 40 barg. Max. working pressure 40 bar. Working temperature -20°C +300°C. Lever for manual opening, open cap.

Applications: Gas or steam

MED.	PN	P	A	B	C	D	G	H1	H2
DN15 x 1"	16/40	13	87	144	35	45	95	50	137
DN20 x 1"	16/40	14	88	144	35	45	105	50	137
DN25 x 1"	16/40	16	94	144	35	45	115	50	137
DN25 x 1 1/4"	16/40	16	98	141	35	45	115	50	137
DN32 x 1 1/4"	16/40	20	102	141	35	45	140	50	137
DN40 x 2"	16/40	28	126	226	46	65	150	50	196
DN50 x 2"	16/40	32	127	226	46	65	165	50	196

2257 04 06	1/2" x 1"	2.27	316,83
2257 05 06	3/4" x 1"	2.6	337,44
2257 06 06	1" x 1"	2.93	358,11
2257 06 07	1" x 1 1/4"	3.065	420,74
2257 07 07	1 1/4" x 1 1/4"	3.99	459,22
2257 08 09	1 1/2" x 2"	6.52	726,81
2257 09 09	2" x 2"	7.42	777,86

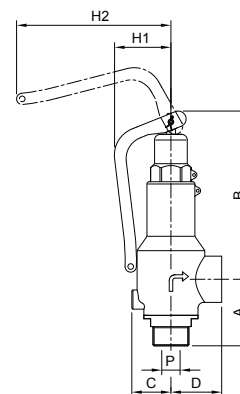

Información técnica
Technical information

Ref.2258 - 2258N



Válvula de Alivio de Presión

Conexión rosca gas BSP M-H s/ ISO228/1, disponible con rosca NPT (2258N). Construcción: Acero Inoxidable 1.4408 (CF8M). Cierre PTFE. Tara entre 0,5 barg y 25 barg. Presión máxima de trabajo 25 bar. Temperatura de trabajo -20°C +200°C.

Pressure relief valve

BSP threaded ends acc./ ISO 228/1 M-F, available with NPT threaded (2258N). Construction: Stainless steel 1.4408 (CF8M). PTFE sealing. Set pressure between 0,5 barg and 25 barg. Max. working pressure 25 bar. Working temperature -20°C +200°C.

2258 04 06 11	1/2" x 1"	1.78	220,30
2258 05 06 11	3/4" x 1"	1.79	226,67
2258 06 06 11	1" x 1"	1.78	234,02
2258 06 07 11	1" x 1 1/4"	1.88	262,14
2258 07 07 11	1 1/4" x 1 1/4"	1.813	266,61
2258 08 09 11	1 1/2" x 2"	3.7	465,42
2258 09 09 11	2" x 2"	3.8	472,75

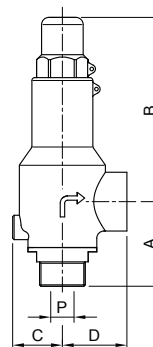

Información técnica
Technical information

Ref.2259



Válvula de Alivio de Presión.

Extremo bridado PN25 (entrada) según EN 1092-1 y rosca gas BSP s/ ISO228/1 (salida). Construcción: Acero Inoxidable 1.4408 (CF8M). Cierre PTFE. Tara entre 0,5 barg y 25 barg. Presión máxima de trabajo 25 bar. Temperatura de trabajo -20°C +200°C.

Pressure relief valve.

Flanged end PN25 (inlet) acc. to EN 1092-1 and threaded end BSP acc. to ISO 228/1 (outlet). Construction: Stainless steel 1.4408 (CF8M). PTFE sealing. Set pressure between 0,5 barg and 25 barg. Max. working pressure 25 bar. Working temperature -20°C +200°C.

CÓDIGO CODE	MEDIDA SIZE	PESO WEIGHT	P.V.P. € PRICE €
2259 04 06 11	1/2" x 1"	2.7	280,07
2259 05 06 11	3/4" x 1"	2.52	300,68
2259 06 06 11	1" x 1"	2.84	321,35
2259 06 07 11	1" x 1 1/4"	2.98	383,42
2259 07 07 11	1 1/4" x 1 1/4"	3.87	421,92
2259 08 09 11	1 1/2" x 2"	6.4	677,04
2259 09 09 11	2" x 2"	7.29	728,11

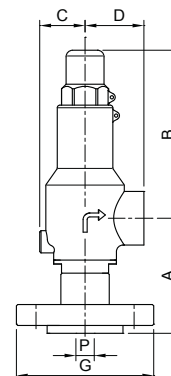

Información técnica
Technical information

Ref.2272 - 2272N



Válvula reductora de presión inoxidable

Construcción: acero inox. CF8M (316) microfundición. También disponible en NPT (2272N). Extremos rosca gas ISO 228-1. Asiento y diafragma FPM (Viton). Presión máxima de entrada 25 bar. Presión de salida: 1 - 6 bar (tarado a 3 bar). Temperatura de trabajo: -15°C +120°C.

Stainless steel pressure reducing valve

Construction: stainless steel CF8M (316) investment casting. Also available with NPT thread (2272N). Gas threaded ends ISO 228-1. Seat and diaphragm in FPM (viton). Maxim input pressure 25 bar. Outlet pressure: 1 - 6 bar (preset 3 bar). Working temperature: -15°C +120°C.

DN	R	H	L
15	1/2"	100	70
20	3/4"	100	85
25	1"	105	92

2272 04	1/2"	0.782	185,04
2272 05	3/4"	0.892	221,25
2272 06	1"	1.098	316,27
2272N 04	1/2"	0.785	194,29
2272N 05	3/4"	0.894	232,31
2272N 06	1"	1.107	332,08

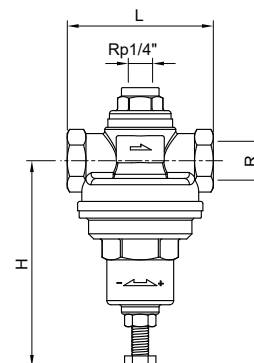

Información técnica
Technical information

Ref.2274 - 2274N



Válvula Reductora de Presión pilotada.

Conexión rosca gas s/ISO 7-1, disponible con rosca NPT (2274N). Construcción: Acero al Carbono 1.0619 (WCB). Presión de entrada máxima 25 bar. Presión de salida desde 0,5 a 12 bar. Temperatura máxima de trabajo 260°C. (Aplicación en vapor o aire comprimido)

Pilot operated Pressure Reducing Valve.

Threaded ends acc. to ISO 7-1, available with NPT threaded (2274N). Construction: Carbon steel 1.0619 (WCB). Maximum input pressure 25 bar. Outlet pressure from 0,5 to 12 bar. Maximum working temperature 260°C. (Steam or compressed air applications)

MED.	PN	L	H	H1	D
1/2"	25	147	150	302	185
3/4"	25	150	155	302	185
1"	25	160	165	308	210
1 1/4"	25	180	175	308	210
1 1/2"	25	200	196	316	255
2"	25	230	205	324	255

2274 04	1/2"	14.331	1473,18
2274 05	3/4"	14.779	1564,62
2274 06	1"	16.9	1645,90
2274 07	1 1/4"	17.85	1840,12
2274 08	1 1/2"	26.85	2312,98
2274 09	2"	30.45	2702,08

Precios rosca NPT a consultar / NPT thread prices on request

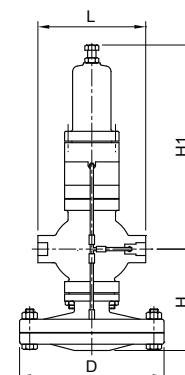

Información técnica
Technical information

Ref.2275



Válvula Reductora de Presión pilotada extremos bridados.

Extremos bridados según EN 1092-1 PN25. Construcción: Acero al Carbono 1.0619 (WCB). Presión de entrada máxima 25 bar. Presión de salida desde 0,5 a 12 bar. Temperatura máxima de trabajo 260°C. (Aplicación en vapor o aire comprimido)

Pilot operated Pressure Reducing Valve flanged ends

Flanged ends according to EN 1092-1 PN25. Construction: Carbon steel 1.0619 (WCB). Maximum input pressure 25 bar. Outlet pressure from 0,5 to 12 bar. Maximum working temperature 260°C. (Steam or compressed air applications)

DN	PN	L	H	H1	D
15	25	147	150	302	185
20	25	150	155	302	185
25	25	160	165	308	210
32	25	180	175	308	210
40	25	200	196	316	255
50	25	230	205	324	255

CÓDIGO CODE	MEDIDA SIZE	PESO WEIGHT	P.V.P. € PRICE €
2275 04	1/2"	15.85	1574,78
2275 05	3/4"	16.46	1645,90
2275 06	1"	19.25	1717,02
2275 07	1 1/4"	21.725	1854,17
2275 08	1 1/2"	30.603	2336,76
2275 09	2"	36.338	2743,15

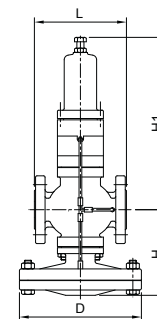

Información técnica
Technical information

Ref. 2281 - 2281N



Válvula Reductora de Presión.

Conexión rosca s/ISO 7-1, disponible con rosca NPT (2281N). Construcción: Acero inox. CF8 (304).

Presión de entrada máxima 16 bar. Presión de salida desde 2 a 8 bar. Temperatura máxima de trabajo 200°C. (Aplicación en vapor)

Pressure Reducing Valve.

Threaded ends acc. to ISO 7-1, available with NPT threaded (2281N). Construction: stainless steel CF8 (304).

Maximum input pressure 16 bar. Outlet pressure from 2 to 8 bar. Maximum working temperature 200°C. (Steam application)

MED.	PN	L	H	H1
1/2"	16	85	140	52
3/4"	16	95	143	55
1"	16	105	146	58

2281 04	1/2"	1.45	418,39
2281 05	3/4"	1.6	421,82
2281 06	1"	1.842	484,88

Precios rosca NPT a consultar / NPT thread prices on request

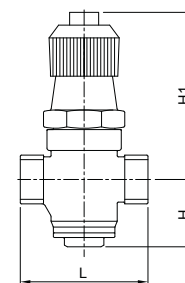

Información técnica
Technical information

Ref.2292



Purgador termostático y Eliminador de aire

PN16. Const.: Latón CW617N. Extremos: rosca gas ISO 228-1. PMO: 14 bar. TMO: 200°C.

Thermostatic steam trap and Air vent

PN16. Const.: Brass CW617N. Gas Threaded ends ISO 228-1. PMO: 14 bar. TMO: 200°C

MED.	H	A	L	M
1/2"	57,5	20	38	50

2292 04	1/2"	0.428	120,81
---------	------	-------	--------

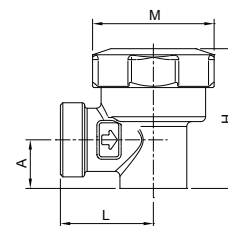

Información técnica
Technical information

Ref.2293



Purgador termostático y Eliminador de aire

PN25. Const.: Acero Inoxidable 304. Extremos: rosca gas ISO 228-1. PMO: 23 bar. TMO: 235°C.

Thermostatic steam trap and Air vent

PN25. Const.: Stainless Steel 304. Gas Threaded ends ISO 228-1. PMO: 23 bar. TMO: 235°C.

MED.	D	A
1/4"	47,5	50,5
3/8"	47,5	58
1/2"	47,5	60

2293 02	1/4"	0.432	129,87
2293 03	3/8"	0.455	132,89
2293 04	1/2"	0.433	141,95

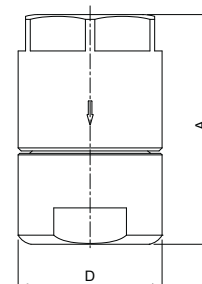

Información técnica
Technical information

Ref. 2282 - 2282N



Purgador termodinámico con filtro incorporado

Extremos: rosca gas ISO 228-1. También disponible con rosca NPT. (2282N) PN 63. Const.: acero inox. 420 (ASTM A743 Gr-CA40). Tamiz: AISI 304. PMO: 52 bar. TMO: 400°C.

Thermodynamic steam trap with strainer

Gas Threaded ends ISO 228-1. Also available with NPT thread. (2282N) PN 63. Const. stainless steel 420 (ASTM A743 Gr-CA40). Strainer screen: AISI 304. PMO: 52 bar. TMO: 400°C.

MED.	A1	A2	L
1/2"	41	57	78
3/4"	46	60	90
1"	54	65	95

CÓDIGO CODE	MEDIDA SIZE	PESO WEIGHT	P.V.P. € PRICE €
2282 04	1/2"	0.86	95,20
2282 05	3/4"	1.168	106,95
2282 06	1"	1.597	128,75

Precios rosca NPT a consultar / NPT thread prices on request

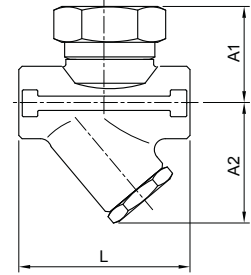

Información técnica
Technical information

Ref. 2284 - 2284N



Purgador termodinámico sin filtro

Extremos: rosca gas ISO 228-1. También disponible con rosca NPT. (2284N). PN 63. Const.: acero inox. 420 (ASTM A743 Gr-CA40). PMO: 52 bar. TMO: 400°C.

Thermodynamic steam trap without strainer

Gas threaded ends ISO 228-1. Also available with NPT thread. (2284N). PN 63. Const. stainless steel 420 (ASTM A743 Gr-CA40). PMO: 52 bar. TMO: 400°C.

MED.	A	L
1/2"	40	70
3/4"	43	80
1"	52	90

2284 04	1/2"	0.502	62,27
2284 05	3/4"	0.772	78,65
2284 06	1"	1.206	110,72

Precios rosca NPT a consultar / NPT thread prices on request

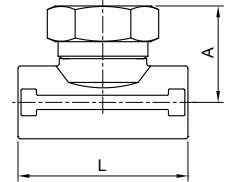

Información técnica
Technical information

Ref. 2294 - 2294N



Purgador termostático con filtro incorporado

PN40. Const.: acero carbono ASTM A105. Tamiz: AISI 304. Extremos: rosca gas ISO 228-1. También disponible con rosca NPT. PMO: 38 bar. TMO: 300°C.

Thermostatic steam trap with strainer

PN40. Const. carbon steel ASTM A105. Strainer screen: AISI 304. Gas Threaded ends ISO 228-1. Also available with NPT Threaded. PMO: 38 bar. TMO: 300°C

MED.	A1	A2	L
1/2"	58	64	95
3/4"	58	66	95
1"	58	68	95

2294 04	1/2"	1.747	117,79
2294 05	3/4"	1.88	120,81
2294 06	1"	2.16	126,85

Precios rosca NPT a consultar / NPT thread prices on request

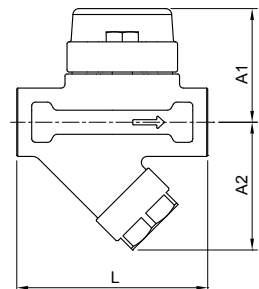

Información técnica
Technical information

Ref. 2295 - 2295N



Purgador Bimetálico con filtro incorporado

También disponible con rosca NPT (2285N)
PN40. Const.: acero carbono ASTM A105. Tamiz:
AISI 304. Extremos: rosca gas ISO 228-1.
También disponible con rosca NPT.
PMO: 38 bar. TMO: 300°C.

Bimetallic steam trap with strainer

Also available with NPT thread (2285N)
PN40. Const. carbon steel ASTM A105. Strainer
screen: AISI 304. Gas Threaded ends ISO 228-1.
Also available with NPT Threaded.
PMO: 38 bar. TMO: 300°C

MED.	A1	A2	L
1/2"	86	64	95
3/4"	86	66	95
1"	86	68	95

CÓDIGO CODE	MEDIDA SIZE	PESO WEIGHT	P.V.P. € PRICE €
2295 04	1/2"	1.96	152,22
2295 05	3/4"	2.12	156,45
2295 06	1"	2.38	160,68

Precios rosca NPT a consultar / NPT thread prices on request

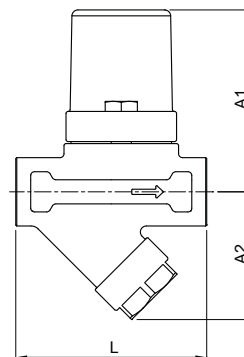

Información técnica
Technical information

Ref. 2285 - 2285N



Purgador de boya cerrada para vapor Purgador de boya cerrada para vapor

Conexión rosca gas BSP s/ISO 228/1. Construcción: Acero al Carbono 1.0619 (WCB). Partes internas en acero inoxidable. Eliminador termostático de aire interno. Instalación horizontal. Máxima presión de trabajo PN16. Presión diferencial máxima: 4,5 bar (045) ó 10 bar (100). Temperatura máxima de trabajo 250°C.

Ball float steam trap Ball float steam trap

BSP threaded ends acc. to ISO 228/1. Construction: Carbon steel 1.0619 (WCB). Internal parts made of stainless steel. Internal air vent assembly. Horizontal installation. Maximum working pressure PN16. Maximum differential pressure: 4,5 bar (045) or 10 bar (100). Maximum working temperature 250°C.

MED.	PN	A	B	C	D
1/2"	16	121	107	75	158
3/4"	16	121	107	75	158
1"	16	145	107	75	166

2285 04 045	1/2"	3.688	271,91
2285 04 100	1/2"	3.742	271,91
2285 05 045	3/4"	3.67	281,98
2285 05 100	3/4"	3.644	281,98
2285 06 045	1"	4.72	292,03
2285 06 100	1"	4.772	292,03

Precios rosca NPT a consultar / NPT thread prices on request

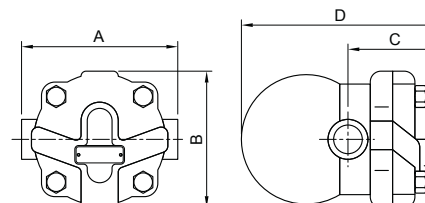

Información técnica
Technical information

Ref. 2286



Purgador de boya cerrada para vapor

Extremos bridados según EN 1092-1 PN16. Construcción: Acero al Carbono 1.0619 (WCB). Partes internas en acero inoxidable. Eliminador termostático de aire interno. Instalación horizontal. Máxima presión de trabajo PN16. Presión diferencial máxima: 4,5 bar (045) ó 10 bar (100). Temperatura máxima de trabajo 250°C.

Ball float steam trap

Flanged ends according to EN 1092-1 PN16. Construction: Carbon steel 1.0619 (WCB). Internal parts made of stainless steel. Internal air vent assembly. Horizontal installation. Maximum working pressure PN16. Maximum differential pressure: 4,5 bar (045) or 10 bar (100). Maximum working temperature 250°C.

MED.	PN	A	B	C	D
1/2"	16	150	95	75	90
3/4"	16	150	105	75	90
1"	16	160	115	70	104

2286 04 045	1/2"	5.015	302,11
2286 04 100	1/2"	4.893	302,11
2286 05 045	3/4"	5.477	312,19
2286 05 100	3/4"	5.493	312,19
2286 06 045	1"	6.82	342,40
2286 06 100	1"	6.908	342,40

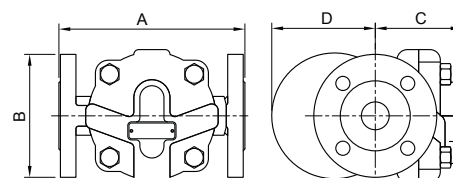

Información técnica
Technical information

Ref.2286A



Purgador de boya cerrada para vapor.

Extremos bridados según ASME B-16.5 S-150. Construcción: Acero al Carbono 1.0619 (WCB). Partes internas en acero inoxidable. Eliminador termostático de aire interno. Instalación horizontal. Máxima presión de trabajo PN19. Presión diferencial máxima: 4,5 bar (045) o 10 bar (100). Temperatura máxima de trabajo 250°C.

Ball float steam trap.

Flanged ends according to ASME B-16.5 S-150. Construction: Carbon steel 1.0619 (WCB). Internal parts made of stainless steel. Internal air vent assembly. Horizontal installation. Maximum working pressure PN19. Maximum differential pressure: 4,5 bar (045) or 10 bar (100). Maximum working temperature 250°C.

MED.	A	B	C	D
1/2"	170	90	101	55
3/4"	170	100	101	55
1"	210	110	70	100

CÓDIGO CODE	MEDIDA SIZE	PESO WEIGHT	P.V.P. € PRICE €
2286A 04 045	1/2"	4.68	317,22
2286A 04 100	1/2"	4.727	317,22
2286A 05 045	3/4"	5	327,80
2286A 05 100	3/4"	4.953	327,80
2286A 06 045	1"	6.987	359,52
2286A 06 100	1"	6.987	359,52

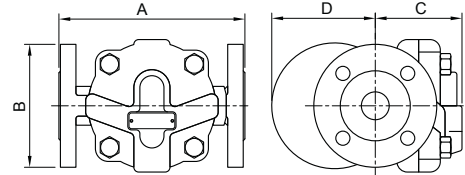

Información técnica
Technical information

Ref.2287



Purgador de boya cerrada para vapor (alta capacidad de descarga)

Extremos bridados según EN 1092-1 PN16. Construcción: Acero al Carbono 1.0619 (WCB). Partes internas en acero inoxidable. Eliminador termostático de aire interno. Instalación horizontal. DN25: asiento simple, DN40/50: Asiento doble. Máxima presión de trabajo PN16. Presión diferencial máxima: 4,5 bar (045) ó 10 bar (100). Temperatura máxima de trabajo 250°C.

Ball float steam trap (high capacity discharge)

Flanged ends according to EN 1092-1 PN16. Construction: Carbon steel 1.0619 (WCB). Internal parts made of stainless steel. Internal air vent assembly. Horizontal installation. DN25: Single seat, DN40/50: Double seat. Maximum working pressure PN16. Maximum differential pressure: 4,5 bar (045) or 10 bar (100). Maximum working temperature 250°C.

MED.	PN	A	B	C	D
1"	16	160	105	70	250
1 1/2"	16	230	120	92	317
2"	16	230	140	125	330

2287 06 045	1"	9.823	383,63
2287 06 100	1"	9.77	383,63
2287 08 045	1 1/2"	27.033	931,53
2287 08 100	1 1/2"	26.937	931,53
2287 09 045	2"	27.313	1026,62
2287 09 100	2"	27.521	1026,62

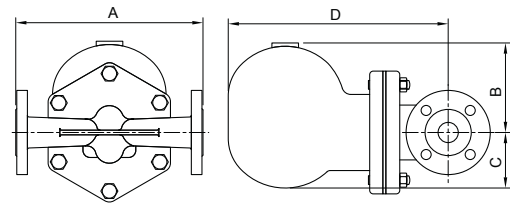

Información técnica
Technical information

Ref.2287A



Purgador de boya cerrada para vapor (alta capacidad de descarga).

Extremos bridados según ASME B-16.5 S-150. Construcción: Acero al Carbono 1.0619 (WCB). Partes internas en acero inoxidable. Eliminador termostático de aire interno. Instalación horizontal. DN25: asiento simple, DN40/50: Asiento doble. Máxima presión de trabajo PN19. Presión diferencial máxima: 4,5 bar (045) o 10 bar (100). Temperatura máxima de trabajo 250°C.

Ball float steam trap (high capacity discharge).

Flanged ends according to ASME B-16.5 S-150. Construction: Carbon steel 1.0619 (WCB). Internal parts made of stainless steel. Internal air vent assembly. Horizontal installation. DN25: Single seat, DN40/50: Double seat. Maximum working pressure PN19. Maximum differential pressure: 4,5 bar (045) or 10 bar (100). Maximum working temperature 250°C.

MED.	A	B	C	D
1"	160	105	70	250
1 1/2"	230	140	125	330
2"	230	140	125	330

2287A 06 045	1"	9.78	402,82
2287A 06 100	1"	9.633	402,82
2287A 08 045	1 1/2"	26.94	978,11
2287A 08 100	1 1/2"	24.767	978,11
2287A 09 045	2"	29.113	1077,95
2287A 09 100	2"	26.277	1077,95

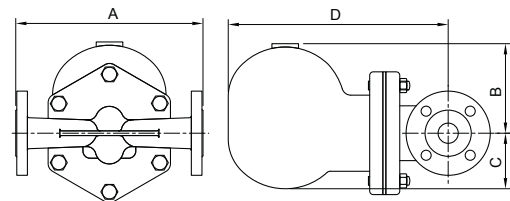

Información técnica
Technical information

Ref. 2288 - 2288N



Purgador de Cubeta Invertida para vapor.

Conexión rosca gas BSP s/ISO 228/1, disponible con rosca NPT (2288N).
Construcción: Fundición GGG-40. Partes internas en acero inoxidable.
Instalación horizontal.
Máxima presión de trabajo PN16. Presión diferencial máxima: 5 bar (050) - 9 bar (090) o 14 bar (140). Capacidad de descarga máxima: 500 Kg/h. Temperatura máxima de trabajo 300°C.

Inverted Bucket steam trap.

BSP threaded ends acc. to ISO 228/1, available with NPT threaded (2288N).
Construction: Ductile Iron GGG-40. Internal parts made of stainless steel.
Horizontal installation.
Maximum working pressure PN16. Maximum differential pressure: 5 bar (050) - 9 bar (090) or 14 bar (140). Flow rate Capacity: 500 Kg/h. Maximum working temperature 300°C.

MED.	H	A	L
1/2"	195	83	120
3/4"	195	83	120

CÓDIGO CODE	MEDIDA SIZE	PESO WEIGHT	P.V.P. € PRICE €
2288 04 050	1/2"	3.653	141,95
2288 04 090	1/2"	3.64	141,95
2288 04 140	1/2"	3.633	141,95
2288 05 050	3/4"	3.58	144,97
2288 05 090	3/4"	3.567	144,97
2288 05 140	3/4"	3.56	144,97

Precios rosca NPT a consultar / NPT thread prices on request

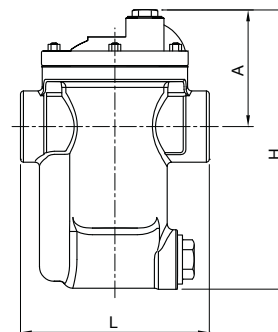

Información técnica
Technical information

Ref. 2289 - 2289N



Purgador de Cubeta Invertida para vapor.

Conexión rosca gas BSP s/ISO 228/1, disponible con rosca NPT (2289N).
Construcción: Fundición GGG-40. Partes internas en acero inoxidable.
Instalación horizontal.
Máxima presión de trabajo PN16. Presión diferencial máxima: 5 bar (050) - 9 bar (090) o 14 bar (140). Capacidad de descarga máxima: 1000 Kg/h. Temperatura máxima de trabajo 300°C.

Inverted Bucket steam trap.

BSP threaded ends acc. to ISO 228/1, available with NPT threaded (2289N).
Construction: Ductile Iron GGG-40. Internal parts made of stainless steel.
Horizontal installation.
Maximum working pressure PN16. Maximum differential pressure: 5 bar (050) - 9 bar (090) or 14 bar (140). Flow rate Capacity: 1000 Kg/h. Maximum working temperature 300°C.

MED.	H	A	L
3/4"	250	110	170
1"	250	110	170

2289 05 050	3/4"	8.04	229,54
2289 05 090	3/4"	8.027	229,54
2289 05 140	3/4"	8.02	229,54
2289 06 050	1"	7.96	235,58
2289 06 090	1"	7.92	235,58
2289 06 140	1"	7.98	235,58

Precios rosca NPT a consultar / NPT thread prices on request

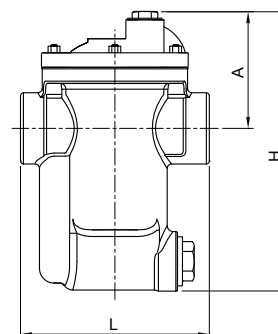

Información técnica
Technical information

Ref. 2296N **NEW**



Separador de Gota con roscas

Separador de condensado en acero al carbono.
Diseño compacto (vertical), alta durabilidad y fácil mantenimiento.
Elimina la humedad en sistemas de vapor, aire comprimido o gas.
Aplicación: Drenaje de líneas de Vapor o Gas.
Extremos roscados según ASME B1.20.1 NPT.
Condiciones de Trabajo: Máxima presión de diseño del cuerpo: PN16.
Presión máxima admisible (PMA): 16 bar (100 °C).
Temp. máxima admisible (TMA): 300 °C (11 bar).
Temp. mínima admisible: 0 °C.
Presión máxima de trabajo vapor saturado: 13,8 bar.
Instalación en tubería horizontal.

Moisture Separator with threads

Carbon Steel moisture separator.
Compact structure (vertical), High durability and easy maintenance.
Removes moisture from steam, compressed air or gas systems.
Application: Steam or Gas pipelines drainage.
Threaded ends according to ASME B1.20.1 NPT.
Working Conditions: Body design conditions: PN16.
Maximum allowable pressure (PMA): 16 bar (100 °C).
Maximum allowable temp. (TMA): 300°C (11 bar).
Minimum allowable temp.: 0°C.
Maximum working pressure saturated steam: 13,8 bar.
Installation in horizontal position.

2296N 04	DN15 - 1/2"	0.565	-	340,10
2296N 05	DN20 - 3/4"	1.2	-	353,70
2296N 06	DN25 - 1"	3.35	-	394,51

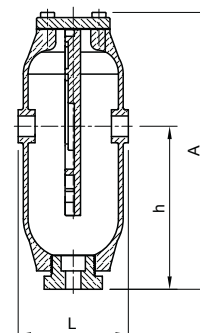

Información técnica
Technical information

MED./Size	A	h	L
1/2"	225	124	90
3/4"	260	156	110
1"	337	222	150

Ref.2297A **NEW**



Separador de gota con bridas

Separador de condensado en fundición nodular. Diseño horizontal, alta durabilidad y fácil mantenimiento. Elimina la humedad en sistemas de vapor, aire comprimido o gas. Aplicación: Drenaje de líneas de Vapor o Gas. Extremos bridados según ASME B 16.5 Clase 150. Longitud entre caras según EN 26554.

Condiciones de Trabajo:
 Máxima presión de Diseño del cuerpo: PN25.
 Presión máxima admisible (PMA) 17,2 bar (38 °C).
 Temp. máxima admisible (TMA): 300 °C (11 bar).
 Temp. mínima admisible: 0 °C.
 Presión máxima de trabajo vapor saturado: 13,8 bar.
 Instalación en tubería horizontal

Moisture Separator with flanges

Moisture separator in Ductile Iron. Horizontal design, High durability and easy maintenance. Removes moisture from steam, compressed air or gas systems. Application: Steam or Gas pipelines drainage. Flanged ends according to ASME B 16.5 Class 150. Face To Face dimension according to EN 26554.

Working Conditions:
 Body design conditions: PN25.
 Maximum allowable pressure (PMA): 17,2 bar (38 °C).
 Maximum allowable temp. (TMA): 300°C (11 bar).
 Minimum allowable temp.: 0 °C.
 Maximum working pressure saturated steam: 13,8.
 Installation in horizontal position

MED./Size	A	D	L	h
1 1/2"	155	127	365	111
2"	205	152	455	156
2 1/2"	250	180	455	178
3"	250	190	480	178
4"	315	230	690	223

CÓDIGO CODE	MEDIDA SIZE	PESO WEIGHT	P.V.P. € PRICE €
2297A 08	1 1/2"	14	544,15
2297A 09	2"	25	598,57
2297A 10	2 1/2"	28	748,21
2297A 11	3"	37	1020,29
2297A 12	4"	60	1224,35

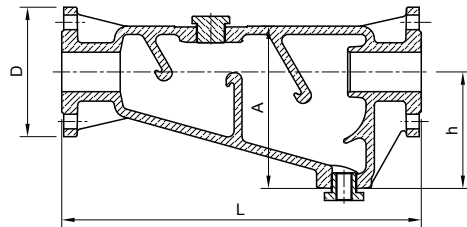

Información técnica
 Technical information

Ref.2401



Tipo wafer. Válvula retención doble disco PN 16

Construcción: cuerpo hierro fundido GG-25. Discos inox CF8M (316). Ejes y resortes: AISI 316. Cojinetes: PTFE. Montaje entre bridas PN 10/16 - ANSI 150 lbs. Asiento nitrilo vulcanizado en ranura.

Wafer type. Double disk check valve PN 16

Body: cast iron GG 25. Disks stainless steel CF8M (316). Stem and spring: AISI (316). Bearings: PTFE. Mounting between flanges PN 10/16 - ANSI 150 lbs. Seat: nitrile vulcanised in the slot.

DN	A	B	C	D
50	101	54	66	27
65	120	54	78	27
80	133	57	89	28
100	164	64	117	30
125	194	70	141	31
150	220	76	168	31
200	275	95	210	41
250	330	108	265	41
300	380	143	311	46

2401 09	2"	1.437	39,83
2401 10	2 1/2"	1.895	46,72
2401 11	3"	2.511	62,26
2401 12	4"	3.951	80,42
2401 13	5"	6.162	108,91
2401 14	6"	7.815	160,23
2401 16	8"	15.245	267,94
2401 18	10"	22.872	424,52
2401 20	12"	40.181	577,46

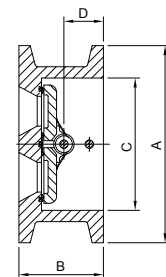

Información técnica
 Technical information

Ref.2402



Tipo wafer. Válvula retención doble disco PN 25

Const.: Acero CF8M (316). Cojinetes PTFE - asiento vitón. Montaje entre bridas PN 25 - ANSI 150 lbs. Asiento vitón vulcanizado en ranura.

Wafer type. Double disk check valve PN 25

Const: Stainless Steel CF8M (316). Bearings: PTFE. Mounting between flanges PN 25- ANSI 150 lbs. Seat: vitón vulcanised in the slot.

DN	A	B	C	D
50	101	54	60	27
65	120	54	73	27
80	133	57	89	28
100	170	64	114	30
125	196	70	141	31
150	226	76	168	31
200	288	95	219	41
250	343	108	273	41
300	403	143	324	46

2402 09	2"	1.397	157,18
2402 10	2 1/2"	1.803	178,34
2402 11	3"	2.378	210,39
2402 12	4"	3.785	285,09
2402 13	5"	6.365	389,15
2402 14	6"	7.782	519,77
2402 16	8"	15.378	978,25
2402 18	10"	21.277	1457,46
2402 20	12"	32.458	2216,40

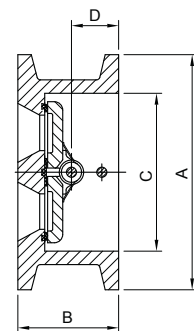

Información técnica
 Technical information

Ref.2406



Tipo wafer. Válvula de retención a clapeta DIN PN 16

Cuerpo y disco acero CF8M (316). Junta tórica: vitón montaje entre bridas PN 10/16 - ANSI 150 lbs.

Wafer type. Disk check valve din PN 16

Body and disk in stainless steel CF8M (316). O'ring: viton. Mounting between flanges PN 10/16 - ANSI 150 lbs.

DN	d	D	S
40	25	85	12
50	32	105	14
65	40	124	14
80	54	136	14
100	70	164	18
125	92	194	18
150	114	220	20
200	154	275	22
250	200	330	26
300	230	384	30

CÓDIGO CODE	MEDIDA SIZE	PESO WEIGHT	P.V.P. € PRICE €
2406 08	1 1/2"	0.443	61,49
2406 09	2"	0.793	66,51
2406 10	2 1/2"	1.07	82,12
2406 11	3"	1.25	106,33
2406 12	4"	2.302	150,59
2406 13	5"	3.156	193,52
2406 14	6"	4.518	252,90
2406 16	8"	7.579	436,82
2406 18	10"	12.696	703,81
2406 20	12"	19.447	1431,29

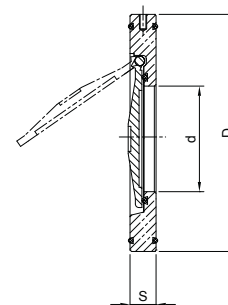

Información técnica
Technical information

Ref.2415



Tipo Wafer. Válvula retención disco PN 40 ≤ 100. PN 25 > DN100

Construcción: CF8M (316). disco y resorte: CF8M (316). Montaje entre bridas PN 10/40. ANSI 150 lbs. Longitud s/DIN 3202 K4.

Wafer type. Disk check valve PN 40 ≤ 100. PN 25 > DN100

Constr.: CF8M (316). Disk and spring: CF8M (316). Mounting between flanges PN 10/40. ANSI 150 lbs. Length: DIN 3202 K4.

DN	PN	D	B	A	L
15	40	39	15	34	16
20	40	46	20	41	19
25	40	54	25	49	22
32	40	70	32	62	28
40	40	81	40	71	32
50	40	94	48	85	40
65	40	113	62	102	46
80	40	132	75	123	50
100	40	150	95	140	60
125	25	187	118	177	90
150	25	217	140	205	106
200	25	274	185	261	140

2415 04	1/2"	0.093	13,09
2415 05	3/4"	0.121	16,83
2415 06	1"	0.207	23,60
2415 07	1 1/4"	0.384	36,06
2415 08	1 1/2"	0.541	48,77
2415 09	2"	0.786	68,74
2415 10	2 1/2"	1.279	104,18
2415 11	3"	1.937	153,42
2415 12	4"	2.761	220,74
2415 13	5"	5.597	447,72
2415 14	6"	8.506	630,98
2415 16	8"	16.15	1243,88

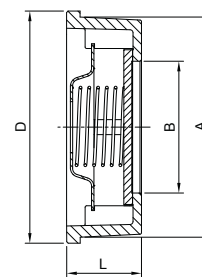

Información técnica
Technical information

Ref.2413 - 2413N



Válvula de retención a disco PN 63

Construcción: acero inox, CF8M (316) microfundición. También disponible con rosca NPT (2413N). Extremos: rosca ISO 7-1 (EN 10226-1). Asiento: PTFE. PN 63, temp: -20°C +200°C.

Disk check valve PN 63

Const. stainless steel CF8M (316) investment casting. Also available with NPT thread (2413N). Threaded ends ISO 7-1 (EN 10226-1). Seat: PTFE. PN 63, temp: -20°C +200°C.

DN	R	B	C
15	1/2"	37	56
20	3/4"	42	63
25	1"	48	74

2413 04	1/2"	0.2	24,72
2413 05	3/4"	0.29	30,88
2413 06	1"	0.397	40,57

Precios rosca NPT a consultar / NPT thread prices on request

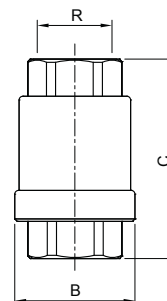

Información técnica
Technical information

Ref. 2416 - 2416N



Válvula de retención a disco PN 63.

Construcción: acero inox. CF8M (316) microfundición. Extremos: rosca ISO 7-1 (EN 10226-1). Disco y resorte: AISI 316. PN 63, temp: -20°C +240°C.

Disk check valve PN 63

Const. stainless steel CF8M (316) investment casting. Threaded ends ISO 7-1 (EN 10226-1). Disk and spring: AISI 316. PN 63, Temp: -20°C +240°C.

DN	R	B	C
8	1/4"	30,5	53
10	3/8"	30,5	53
15	1/2"	37	56
20	3/4"	42	63
25	1"	48	74
32	1 1/4"	58	81
40	1 1/2"	70	91
50	2"	82	97
65	2 1/2"	102,5	118
80	3"	120	138
100	4"	150	158

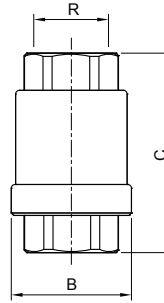

CÓDIGO CODE	MEDIDA SIZE	PESO WEIGHT	P.V.P. € PRICE €
2416 02	1/4"	0.158	21,17
2416 03	3/8"	0.146	21,17
2416 04	1/2"	0.206	22,48
2416 05	3/4"	0.291	28,68
2416 06	1"	0.4	37,50
2416 07	1 1/4"	0.665	54,26
2416 08	1 1/2"	0.966	74,55
2416 09	2"	1.386	100,15
2416 10	2 1/2"	2.582	176,03
2416 11	3"	4.017	262,07
2416 12	4"	6.864	427,07

Precios rosca NPT a consultar / NPT thread prices on request



Información técnica
Technical information

Ref. 2417



Válvula retención a bola

Construcción: cuerpo en acero inox AISI 316. Bola en aluminio recubierta en NBR. Extremos rosca gas ISO 228 PN 16. Temp.: 0°C +90°C.

Ball check valve

Body: stainless steel AISI 316. Ball: aluminium +NBR. Gas threaded ends, ISO 228 PN 16. Temp.: 0°C +90°C.

MED.	A	B
1 1/4"	175	99
1 1/2"	190	99
2"	210	112

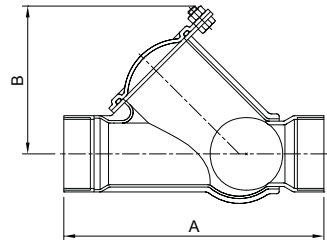

2417 07	1 1/4"	1.1	249,51
2417 08	1 1/2"	1.15	247,83
2417 09	2"	1.6	271,29



Información técnica
Technical information

Ref. 2430 - 2430N



Válvula retención a clapeta oscilante PN 16

Construcción: inox. CF8M (316) microfundición. Juntas: PTFE Conexión: rosca ISO 7-1. Presión máx.: 16 bar a 120°C - 10 bar a 180°C. Temp. mín.: -30°C.

Swing check valve PN 16

Constr. Stainless steel CF8M (316) investment casting. Seals: PTFE; threaded ends ISO 7-1. Max. pressure: 16 bar at 120°C - 10 bar at 180°C. Min. temp.: -30°C.

R	DN	L	H
1/2"	15	65	44
3/4"	20	80	53
1"	25	90	58
1 1/4"	32	105	62
1 1/2"	40	120	73
2"	50	141	78

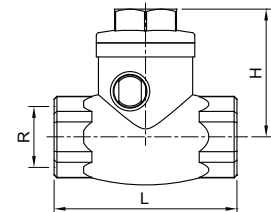

2430 04	1/2"	0.327	45,44
2430 05	3/4"	0.534	55,31
2430 06	1"	0.754	78,32
2430 07	1 1/4"	1.054	102,53
2430 08	1 1/2"	1.633	145,01
2430 09	2"	2.331	177,71

Precios rosca NPT a consultar / NPT thread prices on request



Información técnica
Technical information

Ref. 2440



Válvula retención "Cromax" - "Idrja"

Construcción: AISI 304 - asiento vitón. Extremos roscados ISO 228. Temp. de trabajo, mín. -25°C máx. +150°C. Presión de trabajo, 16 bar. Presión de apertura, 0,03 bar.

"Cromax" check valve "Idrja"

Constr.: AISI 304 - viton seat. Gas threaded ends ISO 228. Working temp. min. -25°C +150°C. Working pressure: 16 bar. Opening pressure: 0.03 bar.

DN	A	B	C
8	18	55	32
12	20	55	32
15	25	55	32
20	30	67	44
25	36	83	53
32	45	97	62
40	51	115	78
50	63	121	89
65	80	141	113

2440 02	1/4"	0.106	25,69
2440 03	3/8"	0.092	25,70
2440 04	1/2"	0.093	23,70
2440 05	3/4"	0.129	29,50
2440 06	1"	0.17	34,65
2440 07	1 1/4"	0.289	45,32
2440 08	1 1/2"	0.413	56,67
2440 09	2"	0.652	115,61
2440 10	2 1/2"	1.274	215,09

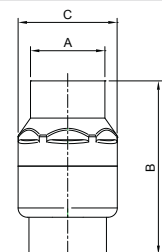

Información técnica
Technical information

Ref.2442



Filtro válvula retención inox 304

Construcción: AISI 304 malla AISI 304. Extremos roscados. Gas ISO 228 PN 16. Diámetro malla: 1/2" a 2": máx. 1 mm - 2 1/2" a 4": máx. 1,9 mm.

Strainer for check valve

Const. stainless steel AISI 304. Sieve AISI 304, gas. Threaded ends ISO 228 PN 16. Sieve diameter: 1/2" to 2": max. 1 mm - 2 1/2" to 4": max. 1,9 mm.

A	B	C	D	E	F	G	H
1/2"	56,5	17,5	22	23	4	10	15
3/4"	62,5	22	28	29	4	10	15
1"	70	28,5	36	37	4	10	15
1 1/4"	80	36,5	43	44	5	14	20
1 1/2"	90	42,5	48	49	5	14	20
2"	100	54,5	61	62	5,5	14	20
2 1/2"	115	70,5	79,5	80,5	5,5	16	25
3"	125	83	92	93	6	16	25
4"	145	108,5	116	117	6	16	25

CÓDIGO CODE	MEDIDA SIZE	PESO WEIGHT	P.V.P. € PRICE €
2442 04	1/2"	0.013	6,46
2442 05	3/4"	0.021	7,62
2442 06	1"	0.03	8,99
2442 07	1 1/4"	0.05	10,05
2442 08	1 1/2"	0.06	12,07
2442 09	2"	0.074	15,12
2442 10	2 1/2"	0.123	41,01
2442 11	3"	0.168	42,02
2442 12	4"	0.225	43,16

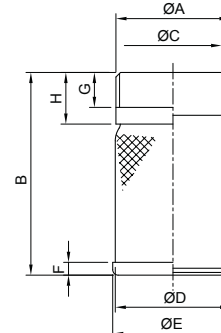

Información técnica
Technical information

Ref.2445 - 2445N



Válvula retención "Cromax" - "Idrja"

Construcción: AISI 316 - asiento vitón. Extremos rosca gas ISO 228, También disponible en rosca NPT (2445N). Temp. de trabajo, mín. -25°C - máx. +150°C. Presión de trabajo, 16 bar. Presión de apertura, 0,03 bar.

"Cromax" check valve "Idrja"

Constr.: AISI 316 - seat viton. Gas threaded ends ISO 228, also available with NPT thread (2445N). Working temp. min. -25°C max. +150°C. Working pressure: 16 bar. Opening pressure: 0.03 bar.

DN	A	B	C
8	25	55	32
12	25	55	32
15	25	55	32
20	30	67	44
25	36	83	53
32	45	97	62
40	51	115	78
50	63	121	89
65	80	141	113
80	93	164	132
100	120	191	167

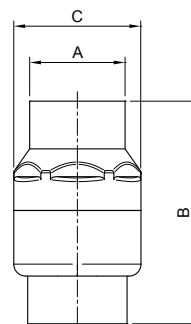

2445 02	1/4"	0.1	47,97
2445 03	3/8"	0.091	47,97
2445 04	1/2"	0.095	47,97
2445 05	3/4"	0.129	52,58
2445 06	1"	0.2	59,86
2445 07	1 1/4"	0.3	84,43
2445 08	1 1/2"	0.388	90,95
2445 09	2"	0.704	178,90
2445 10	2 1/2"	1.425	282,19
2445 11	3"	1.831	411,00
2445 12	4"	3.5	621,32

Precios rosca NPT a consultar / NPT thread prices on request



Información técnica
Technical information

Ref.2447 - 2447N



Filtro válvula retención

Extremos roscados gas ISO 228 PN 16, también disponible en rosca NPT (2447N). Construcción: AISI 316 malla AISI 316. Diámetro malla: 1/2" a 2": máx. 1 mm - 2 1/2" a 4": máx. 1,9 mm.

Strainer for check valve

Gas threaded ends ISO 228 PN 16, also available with NPT thread (2447N). Const.: sieve stainless steel AISI 316. Steel AISI 316. Sieve diameter: 1/2" to 2": max. 1 mm. 2 1/2" to 4": max. 1,9 mm.

A	B	C	D	E	F	G	H
1/2"	56,5	17,5	22	23	4	10	15
3/4"	62,5	22	28	29	4	10	15
1"	70	28,5	36	37	4	10	15
1 1/4"	80	36,5	43	44	5	14	20
1 1/2"	90	42,5	48	49	5	14	20
2"	100	54,5	61	62	5,5	14	20
2 1/2"	115	70,5	79,5	80,5	5,5	16	25
3"	125	83	92	93	6	16	25
4"	145	108,5	116	117	6	16	25

2447 04	1/2"	0.013	10,06
2447 05	3/4"	0.021	11,86
2447 06	1"	0.03	14,15
2447 07	1 1/4"	0.051	16,04
2447 08	1 1/2"	0.06	19,09
2447 09	2"	0.076	28,42
2447 10	2 1/2"	0.127	58,95
2447 11	3"	0.167	64,76
2447 12	4"	0.231	71,93

Precios rosca NPT a consultar / NPT thread prices on request

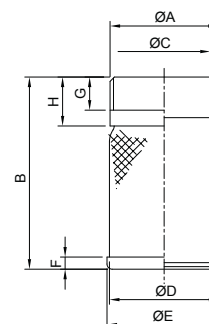

Información técnica
Technical information

Ref.2448



Válvula de retención de pie con brida DIN PN 16

Construcción en acero inoxidable CF8M (316). Asiento de vitón, junta PTFE. Con sistema manual de vaciado. Presión máxima de trabajo 16 bar.

Foot check valve with DIN PN 16 flange end

Stainless steel material CF8M (316). Seat viton material, gasket PTFE. With manual system to empty. Max. working pressure 16 bar.

MED.	DN	D	L
2"	50	165	170
2 1/2"	65	185	183
3"	80	200	198
4"	100	220	242
5"	125	250	282
6"	150	285	326
8"	200	340	440

CÓDIGO CODE	MEDIDA SIZE	PESO WEIGHT	P.V.P. € PRICE €
2448 09	2"	4.683	337,79
2448 10	2 1/2"	6.683	436,97
2448 11	3"	9.32	598,41
2448 12	4"	12.996	906,43
2448 13	5"	19.908	1164,34
2448 14	6"	28.248	1729,44
2448 16	8"	52.493	3003,55

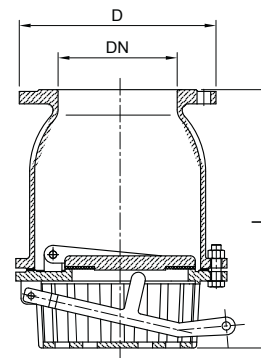

Información técnica
Technical information

Ref.2449



Válvula de retención - "Idrja" con Bridas PN 16

Construcción: AISI 316 - Asiento vitón.
Temp. de trabajo: -20°C +150°C.
Presión de trabajo: 16 bar. Presión de apertura: 0,035 bar.

Check valve - "Idrja" with DIN PN 16 flange ends

Const.: AISI 316 - Viton seat.
Working temp: -20°C +150°C.
Working pressure: 16 bar. Opening pressure: 0,035 bar.

MED	A	B	C
5"	266	250	114
6"	284	285	146
8"	318	340	188

2449 13	5"	18	2501,09
2449 14	6"	24	3653,28
2449 16	8"	36	6123,05

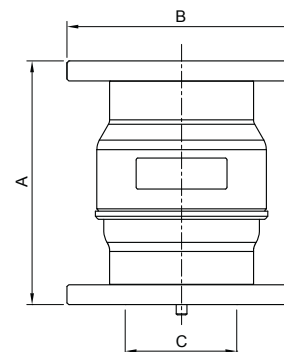

Información técnica
Technical information

Ref.2450



Válvula retención a disco con bridas DIN PN 16

Cuerpo: fund. hierro GG-25. Disco: fund. hierro GG-25. Guía: DN 50-80 latón DIN -17660. Guía: DN 100-250 fund. GG-25. Soporte: latón DIN 17660. Cierre blando: NBR 80SH.

Disk check valve with flanges DIN PN 16

Body and disk: cast iron GG-25. Guide: DN 50-80 brass DIN 17660. Guide: DN 100-250 cast iron GG-25. Bracket: brass DIN 17660. Soft sealing: NBR 80SH.

MED.	Ø	B	C
2"	51	165	100
2 1/2"	63	185	120
3"	80	200	140
4"	100	220	170
5"	125	250	200
6"	150	285	230
8"	200	340	300
10"	250	405	370

2450 09	2"	5.074	86,91
2450 10	2 1/2"	7.326	134,08
2450 11	3"	9.347	145,84
2450 12	4"	12.489	187,71
2450 13	5"	20.684	254,75
2450 14	6"	29.01	371,29
2450 16	8"	47.06	569,05
2450 18	10"	70.544	868,10

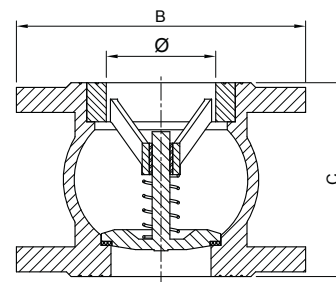

Información técnica
Technical information

Ref.2451



Filtro colador para ensamblar - brida PN 16

Construcción acero zincado.

Strainer for assembling - flange PN 16

Constr.: in zinc plated steel.

MED.	A	B	D
2"	80	155	110
2 1/2"	100	175	130
3"	125	200	145
4"	150	210	165
5"	180	240	195
6"	205	275	220
8"	255	330	275
10"	300	385	330

CÓDIGO CODE	MEDIDA SIZE	PESO WEIGHT	P.V.P. € PRICE €
2451 09	2"	0.631	26,01
2451 10	2 1/2"	0.813	31,97
2451 11	3"	0.982	43,20
2451 12	4"	1.286	56,35
2451 13	5"	1.668	71,40
2451 14	6"	2.093	85,53
2451 16	8"	3.029	109,70
2451 18	10"	4.239	154,71

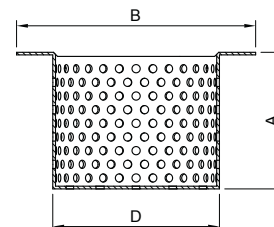

Información técnica
Technical information

Ref.2453



Válvula retención a bola - bridas DIN PN 16

Cuerpo fundido hierro GGG-40. Esfera recubierta con NBR. Presión máx: 16 bar. Temperatura: -10°C +80°C. Dimensiones entre caras según DIN 3202 F6.

Check valve with ball - flanges DIN PN 16

Body and disk: cast iron GGG-40. Ball: with NBR coated. Max. pressure: 16 bar. Temp.: -10°C +80°C. Dimensions between sides DIN 3202 F6.

MED.	DN	PN	H	L
2"	50	16	106	200
2 1/2"	65	16	129	240
3"	80	16	146	260
4"	100	16	194	300
5"	125	16	207	350
6"	150	16	240	400
8"	200	16	322	500
10"	250	16	388	600

2453 09	2"	7.491	146,75
2453 10	2 1/2"	10.849	164,10
2453 11	3"	15.079	207,35
2453 12	4"	21.1	274,82
2453 13	5"	33.224	445,44
2453 14	6"	44.771	553,10
2453 16	8"	83.499	1184,76
2453 18	10"	140	2022,80

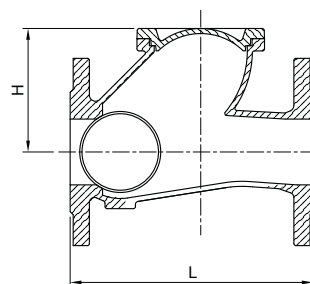

Información técnica
Technical information

Ref.2455



Válvula retención a clapeta oscilante - bridas DIN PN 16

Cuerpo fundido GGG-40. Disco recubierto con EPDM. Presión máx: 16 bar. Temperatura: -10°C +120°C. Dimensiones entre caras según EN558-1/48 (DIN3202 F6).

Swing Check Valve - flanges DIN PN 16

Body: GGG-40. Disk: with EPDM coating. Max. pressure: 16 bar. Temperature: -10°C +120°C. Face to Face according to EN558-1/48 (DIN3202 F6).

MED.	PN	D	A	L
2"	16	165	115	200
2 1/2"	16	185	128	240
3"	16	200	145	260
4"	16	220	163	300
5"	16	250	190	350
6"	16	285	207	400
8"	16	340	253	500
10"	16	405	302	600
12"	16	460	336	700

2455 09	2"	8.959	116,02
2455 10	2 1/2"	11.712	169,96
2455 11	3"	14.713	215,72
2455 12	4"	20.046	259,87
2455 13	5"	28.388	402,03
2455 14	6"	37.342	579,34
2455 16	8"	61.025	855,52
2455 18	10"	94.6	1396,49
2455 20	12"	138.367	1991,35

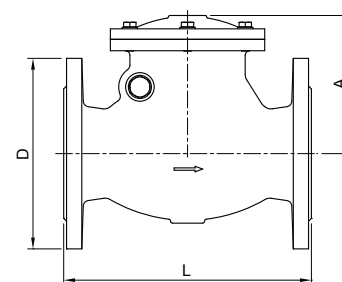

Información técnica
Technical information

Ref.2458G



Filtro "Y" extremos bridados

Construcción: Fundición GGG-40. Junta: PTFE+Grafito. Conexión: Bridas DIN PN 16. Presión de trabajo: 16 bar. Temp: -10°C + 120°C. Tamiz: AISI 304 chapa perforada (ver d1).

Flanged ends "Y" Strainer

Construction: Ductile Iron GGG-40. Gasket: PTFE+Graphite. Ends: Flanges DIN PN 16. Working pressure: 16 bar. Working temp: -10°C +120°C. Screen: AISI 304 perforated plate (see d1)

DN	A	D	L	d1
40	125	150	200	1,5
50	145	165	230	1,5
65	161	185	290	1,5
80	170	200	310	1,5
100	208	220	350	1,5
125	258	250	400	1,5
150	285	285	480	1,5
200	350	340	600	2
250	412	400	730	2
300	480	455	850	2



Información técnica
Technical information

CÓDIGO CODE	MEDIDA SIZE	PESO WEIGHT	P.V.P. € PRICE €
2458G 08	1 1/2"	6.583	64,07
2458G 09	2"	7.696	80,27
2458G 10	2 1/2"	10.002	104,79
2458G 11	3"	11.964	126,92
2458G 12	4"	15.554	176,39
2458G 13	5"	26.835	254,71
2458G 14	6"	32.802	342,79
2458G 16	8"	51.91	604,22
2458G 18	10"	83.44	1059,74
2458G 20	12"	123.936	1522,51

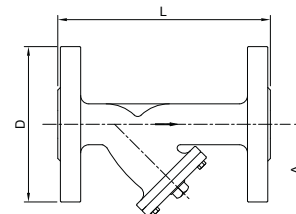

Ref.2459 **NEW**



Filtro "Y" bridas PN16 alta temperatura

Construcción: Fundición GGG-40. Junta: Inoxidable+Grafito. Conexión: Extremos bridados según EN 1092 PN 16. Presión de trabajo: 16 bar. Temp: -25°C +300°C. Tamiz: AISI 304 chapa perforada (ver d1).

Flanged "Y" strainer PN16

Construction: Ductile Iron GGG-40. Gasket: SS+Graphite. Ends: Flanged ends according to EN 1092 PN 16. Working pressure: 16 bar. Working temp: -25°C +300°C. Screen: AISI 304 perforated plate (see d1). 250 psi -20°F +572°F.

Medida/Size	A	D	L	d1
1/2"	80	95	110	1,1
3/4"	90	105	150	1,1
1"	100	115	160	1,1
1 1/4"	110	140	180	1,1
1 1/2"	125	150	200	1,5
2"	145	165	230	1,5
2 1/2"	161	185	290	1,5
3"	170	210	310	1,5
4"	208	220	350	1,5
5"	258	250	400	1,5
6"	285	285	480	1,5
8"	350	340	600	2



Información técnica
Technical information

CÓDIGO CODE	MEDIDA SIZE	PESO WEIGHT	CAJA / BOX CARTON	P.V.P. € PRICE €
2459 04	1/2"	2.2	10	33,74
2459 05	3/4"	3.1	7	47,35
2459 06	1"	3.5	6	53,34
2459 07	1 1/4"	5	4	68,03
2459 08	1 1/2"	6.85	3	74,21
2459 09	2"	7.7	3	91,26
2459 10	2 1/2"	10.15	2	119,13
2459 11	3"	11.98	2	144,29
2459 12	4"	15.6	1	200,52
2459 13	5"	27.4	-	299,76
2459 14	6"	32.82	-	396,92
2459 16	8"	52.1	-	699,63

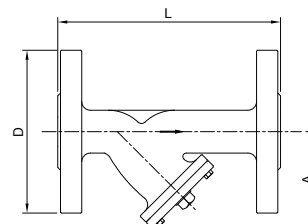

Ref.2459A **NEW**



Filtro "Y" bridas ANSI B16.42 S-150

Construcción: Fundición modular ASTM A536. Junta: Inoxidable+Grafito. Conexión: Bridas ANSI B16.42 S-150. Presión de trabajo: 17 bar. Temp: -29°C +260°C. Tamiz: AISI 304 chapa perforada (ver d1).

Flanged "Y" strainer ANSI B16.42 S-150

Construction: Made of ductile Iron ASTM A5360. Gasket: SS+Graphite. Ends: Flanges ANSI B16.42 S-150. Working pressure: 17 bar. Working temp: -29°C +260°C. Screen: AISI 304 perforated plate (see d1). 250 psi -20°F +572°F.

Medida/Size	A	D	L	d1
1 1/2"	127	152	230	1,1
2"	127	152	230	1,1
2 1/2"	150	178	273	1,1
3"	167	191	295	1,1
4"	201	229	352	1,1
5"	243	254	416	1,5
6"	270	279	470	1,5
8"	338	343	543	1,5



Información técnica
Technical information

CÓDIGO CODE	MEDIDA SIZE	PESO WEIGHT	P.V.P. € PRICE €
2459A 08	1 1/2"	4.2	79,56
2459A 09	2"	6.1	93,58
2459A 10	2 1/2"	9.5	118,84
2459A 11	3"	11.1	161,49
2459A 12	4"	18.4	236,03
2459A 13	5"	25	322,99
2459A 14	6"	34	443,07
2459A 16	8"	57	741,21

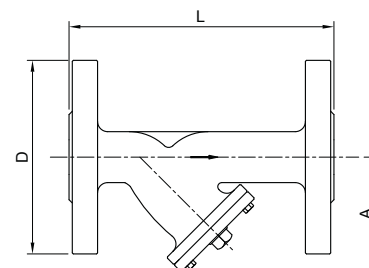

Ref. 2460 - 2460N



Filtro - Y PN 40

Construcción: inox. CF8M (316) microfusión. Juntas: PTFE. Conexión: rosca ISO 7-1 (EN 10226-1). Presión de trabajo: 40 bar. Temperatura: -30°C +240°C. Tamiz: AISI 316 chapa perforada (ver d1).

"Y" strainer PN 40

Constr. stainless steel CF8M (316) investment casting. Seat: PTFE. Threaded end ISO 7-1 (EN 10226-1). Working pressure: 40 bar. Temperature: -30°C +240°C. Screen: AISI 316 perforated plate (see d1).

DN	A	L	d1
1/4"	42	65	1
3/8"	42	65	1
1/2"	44	65	1
3/4"	52	80	1
1"	67	90	1
1 1/4"	71	105	1
1 1/2"	82	120	1
2"	93	140	1

CÓDIGO CODE	MEDIDA SIZE	PESO WEIGHT	P.V.P. € PRICE €
2460 02	1/4"	0.2	15,67
2460 03	3/8"	0.18	15,67
2460 04	1/2"	0.21	15,67
2460 05	3/4"	0.323	24,72
2460 06	1"	0.582	36,57
2460 07	1 1/4"	0.751	52,29
2460 08	1 1/2"	1.069	69,73
2460 09	2"	1.591	96,66

Precios rosca NPT a consultar / NPT thread prices on request

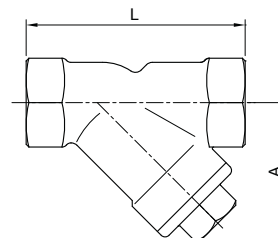

Información técnica
Technical information

Ref. 2463 - 2463N



Filtro "Y" INOX-316 para Vapor

Construcción: inox. CF8M (316) microfusión. Juntas: PTFE. Conexión: rosca ISO 7-1 (EN 10226-1). Presión de trabajo: 40 bar. Temperatura: -30°C +240°C. Tamiz: AISI 316 chapa perforada (ver d1).

"Y" Strainer Stainless-steel 316 for Steam

Constr. stainless steel CF8M (316) investment casting. Seat: PTFE. Threaded end ISO 7-1 (EN 10226-1). Working pressure: 40 bar. Temperature: -30°C +240°C. Screen: AISI 316 perforated plate (see d1).

DN	A	L	d1
1/4"	42	65	0,8
3/8"	42	65	0,8
1/2"	44	65	0,8
3/4"	52	80	0,8
1"	67	90	0,8
1 1/4"	71	105	1
1 1/2"	82	120	0,8
2"	93	140	0,8

2463 02	1/4"	0.2	18,02
2463 03	3/8"	0.18	18,02
2463 04	1/2"	0.22	18,02
2463 05	3/4"	0.35	28,43
2463 06	1"	0.58	42,06
2463 07	1 1/4"	0.77	60,13
2463 08	1 1/2"	1.1	80,19
2463 09	2"	1.6	111,16

Precios rosca NPT a consultar / NPT thread prices on request

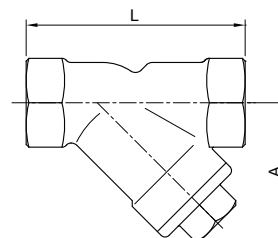

Información técnica
Technical information

Ref. 2462



Filtro en Línea - rosca gas

Construcción: AISI 304 - Junta vitón.
Tamiz: AISI 304
Temp. de trabajo: -10°C +150°C.
Presión de trabajo: 16 bar.

In - Line Filter - Gas thread end

Const.: AISI 304 - Viton Gasket.
Screen: AISI 304
Working temp: -10°C +150°C.
Working pressure: 16 bar.

MED	A	H	L
1/2"	49	44	106
3/4"	55	53	128
1"	68,5	61,5	148
1 1/4"	85	78	180
1 1/2"	106	90,5	219
2"	121,5	130,5	228

2462 04	1/2"	0.2	65,52
2462 05	3/4"	0.285	78,20
2462 06	1"	0.42	83,95
2462 07	1 1/4"	0.725	131,00
2462 08	1 1/2"	1.02	155,00
2462 09	2"	1.4	187,64

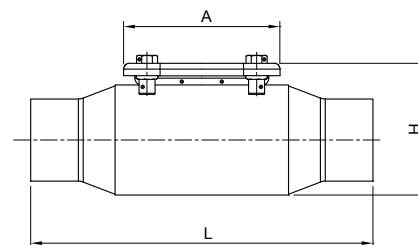

Información técnica
Technical information

Ref.2461

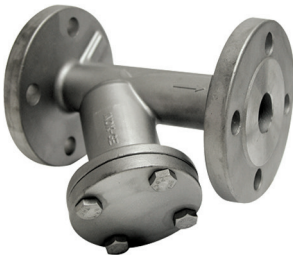

Filtro - Y bridas DIN PN 16

Construcción: Acero inox CF8M (316). Juntas: PTFE conexión: bridas DIN PN 16. Presión de trabajo: 16 bar. Temp.: -30°C +240°C. Tamiz: AISI 316 chapa perforada (ver d1).

Flanged "Y" strainer PN 16

Constr. Stainless Steel CF8M (316). Gaskets: PTFE ends: flanges DIN PN 16. Working pressure: 16 bar. Temperature: -30°C +240°C. Screen: AISI 316 perforated plate (see d1).

DN	A	D	L	d1
15	75	95	130	1
20	90	105	150	1
25	100	115	160	1
32	115	140	180	1
40	130	150	200	1
50	150	165	230	1
65	190	185	290	2
80	200	200	310	2
100	230	220	350	2
125	280	250	400	2
150	300	285	480	2
200	400	340	600	2



Información técnica
Technical information

CÓDIGO CODE	MEDIDA SIZE	PESO WEIGHT	P.V.P. € PRICE €
2461 04	1/2"	1.79	133,87
2461 05	3/4"	2.53	160,74
2461 06	1"	3.56	201,48
2461 07	1 1/4"	4.726	321,44
2461 08	1 1/2"	6.037	337,53
2461 09	2"	8.826	462,47
2461 10	2 1/2"	12.786	665,56
2461 11	3"	17.032	850,26
2461 12	4"	20.088	1305,00
2461 13	5"	30.487	2348,82
2461 14	6"	41.099	3296,04
2461 16	8"	76.896	5324,62

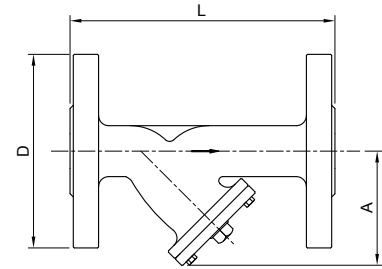

Ref.2461A



Filtro - Y bridas ANSI B 16.5 S-150 Construcción: Acero inoxidable CF8M (316). Juntas: PTFE. Conexión: bridas ANSI. Clase 150. Presión de trabajo: 19 kg/cm2. Temp.: -30°C +240°C. Tamiz: AISI 316 chapa perforada (ver d1).

Strainer Y. Flanged ANSI B 16.5 S-150 Construction: Stainless Steel CF8M (316). Gasket: PTFE. Connection: flanged ANSI. Class 150. Working pressure: 19 kg/cm2. Temp.: -30°C +240°C. Screen: AISI 316 perforated plate (see d1).

275 Psi -22°F + 464°F

MED.	A	D	L	d1
2"	155	152	210	1
2 1/2"	190	178	250	2
3"	200	190	280	2
4"	230	229	340	2
6"	325	279	415	2
8"	397	343	495	2



Información técnica
Technical information

2461A 09	2"	7.374	588,99
2461A 10	2 1/2"	11.385	845,02
2461A 11	3"	14.857	1075,54
2461A 12	4"	23.144	1792,64
2461A 14	6"	41.27	3226,65
2461A 16	8"	72.062	5377,78

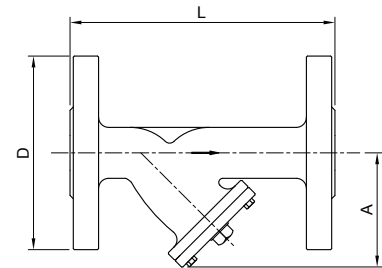

Ref.2525



Válvula esfera paso total 2 piezas bridas DIN PN 16 Montaje directo de actuadores S/ISO 5211. Cuerpo: fundición nodular GGG-40. Esfera y eje: AISI 304. Asientos: PTFE + 15% FV. Tórica eje: vitón. Presión máx.: 16 kg/cm2. Temp. -30°C +180°C. Mando manual por palanca con sistema de bloqueo. L: S/DIN 3202 F-4.

2 pcs. Full bore ball valve flanges DIN PN 16 Body: ductile iron GGG-40. Ball and stem: AISI 304. Seats: PTFE + 15% GF. Stem o'ring: viton. Max. pressure: 16 kg/cm2. Temp. -30°C +180°C. Manually operated by handle with locking system. L: S/DIN 3202 F-4.

MED.	DN	D	L	M	A	ISO 5211
1/2"	15	95	115	130	80	F03/F04
3/4"	20	105	120	130	80	F03/F04
1"	25	115	125	170	90	F04/F05
1 1/4"	32	140	130	170	102	F04/F05
1 1/2"	40	150	140	220	110	F05/F07
2"	50	165	150	220	120	F05/F07
2 1/2"	65	185	170	284	140	F07/F10
3"	80	200	180	284	150	F07/F10
4"	100	220	190	360	180	F07/F10
5"	125	250	325	447	215	F07/F10
6"	150	285	350	560	240	F10/F12
8"	200	340	400	1000	320	F12/F14



Información técnica
Technical information

2525 04	1/2"	2.337	71,46
2525 05	3/4"	2.889	81,22
2525 06	1"	3.981	106,11
2525 07	1 1/4"	5.438	126,63
2525 08	1 1/2"	7.224	152,82
2525 09	2"	9.126	181,81
2525 10	2 1/2"	13.407	284,19
2525 11	3"	18.211	377,55
2525 12	4"	25.498	550,20
2525 13	5"	35.452	1132,02
2525 14	6"	49.977	1619,45
2525 16	8"	94.756	3560,62

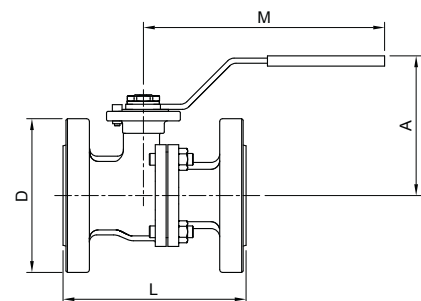

Ref.2526A



Válvula esfera paso total 2 piezas bridas ANSI B 16.5 S-150. Certificación "FIRE SAFE". Montaje directo de actuadores s/ISO 5211. Dispositivo antiestático. Cuerpo: acero al carbono WCB (microfusión). Esfera y eje: AISI 316. Asientos: PTFE + 25 % Grafito. Tórica eje: vitón. Presión máx.: 19 kg/cm2. Temp. -30°C +220°C. Mando manual por palanca con sistema de bloqueo.

2 pcs. Full bore ball valve flanges ANSI B 16.5 S-150. FIRE SAFE Certification. Direct mounting for actuators s/ISO 5211. Antistatic device. Body: carbon steel WCB (investment casting). Ball and stem: AISI 316. Seats: PTFE + 25 % Graphite. Stem o'ring: viton. Max. pressure: 19 kg/cm2. Temp. -30°C +220°C. Manually operated by handle with locking system.

275 Psi -22°F + 356°F

MED.	DN	D	L	M	A	ISO 5211
1/2"	15	89	108	165	90	F04
3/4"	20	98,6	117	165	95	F04/F05
1"	25	108	127	165	95	F04/F05
1 1/4"	32	117	140	165	106	F05/F07
1 1/2"	40	127	165	200	110	F05/F07
2"	50	152,5	178	200	118	F05/F07
2 1/2"	65	177,8	190	400	160	F07/F10
3"	80	190,5	203	400	170	F07/F10
4"	100	228,6	229	400	186	F07/F10
6"	150	279,4	394	800	280	F10/F12



Información técnica
Technical information

CÓDIGO CODE	MEDIDA SIZE	PESO WEIGHT	P.V.P. € PRICE €
2526A 04	1/2"	1.524	49,35
2526A 05	3/4"	1.954	64,80
2526A 06	1"	2.722	89,52
2526A 07	1 1/4"	4.069	124,25
2526A 08	1 1/2"	5.517	172,47
2526A 09	2"	8.174	254,44
2526A 10	2 1/2"	15.147	427,30
2526A 11	3"	19.204	562,95
2526A 12	4"	30.68	955,99
2526A 14	6"	57.075	2433,20

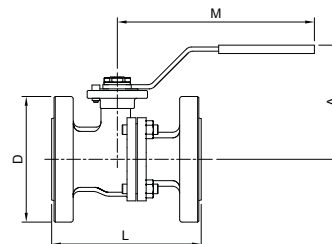

Ref.2528



Válvula esfera paso total 2 piezas bridas DIN, Certificación "FIRE SAFE"

Bridas DIN PN -40 ≤ DN -50.
Bridas DIN PN -16 >DN -50.

Montaje directo de actuadores S/ISO 5211. Cuerpo: inox. CF8M (316) microfusión. Asientos y juntas: PTFE +15% FV tórica eje: vitón. Dispositivo antiestático. Presión máx.: 40/16 bar según medida. Temp.: -30°C +180°C. Mando manual por palanca. Long: S/DIN 3202 F-4 DN 15 DN 100 F-5 DN 125 DN 200.

2 pcs full bore ball valve flanges DIN; FIRE-SAFE Certification

Flanges DIN PN -40 ≤ DN -50.
Flanges DIN PN -16 >DN -50.

Direct mounting for actuators ISO 5211. Body: Stainless steel. CF8M (316) investment casting. Seats: PTFE + 15% GF stem o'ring: viton. Antistatic device. Max. pressure: 40/16 bar depending on size. Temp.: -30°C +180°C. manually operated by handle. L: DIN 3202 F-4 DN 15 DN 100 F-5 DN 125 DN 200.

MED.	PN	Dimensiones/Dimensions mm				ISO 5211
		D	A	L	M	
1/2"	40	95	85	115	170	F04
3/4"	40	105	85	120	170	F04/F05
1"	40	116	95	125	170	F04/F05
1 1/4"	40	140	106	130	200	F05/F07
1 1/2"	40	150	110	140	200	F05/F07
2"	40	165	118	150	200	F05/F07
2 1/2"	16	185	157	170	380	F07/F10
3"	16	200	170	180	380	F07/F10
4"	16	220	184	190	380	F07/F10
5"	16	250	200	325	520	F10/F12
6"	16	285	220	350	620	F10/F12
8"	16	340	334	400	800	F12/F14



Información técnica
Technical information

2528 04	1/2"	2.157	121,40
2528 05	3/4"	3.005	140,93
2528 06	1"	3.839	175,00
2528 07	1 1/4"	5.896	283,98
2528 08	1 1/2"	6.885	312,11
2528 09	2"	9.46	419,21
2528 10	2 1/2"	15.157	671,80
2528 11	3"	19.251	847,10
2528 12	4"	26.779	1209,50
2528 13	5"	38.204	2421,30
2528 14	6"	51.37	3318,69
2528 16	8"	116.51	7830,81

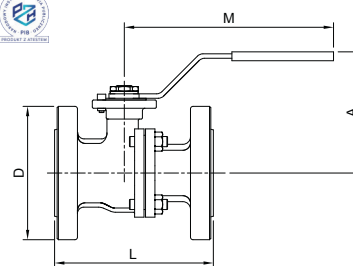

Ref.2528C



Válvula esfera paso total 2 piezas, bridas DIN; Certificación "FIRE SAFE"

Bridas DIN PN -40 ≤ DN -50
Bridas DIN PN -16 >DN -50

Montaje directo de actuadores S/ISO 5211. Cuerpo: inox. CF8M (316) microfusión. Asientos y juntas: PTFE +25% Grafito, tórica eje: vitón. Dispositivo antiestático. Presión máx.: 40/16 bar según medida. Temp.: -30°C +250°C. Mando manual por palanca. Long: S/DIN 3202 F-4 DN 15 DN 100 F-5 DN 125 DN 200.

2 pcs full bore ball valve flanges DIN- FIRE SAFE Certification

Flanges DIN PN -40 ≤ DN -50
Flanges DIN PN -16 >DN -50

Direct mounting for actuators ISO 5211. Body: Stainless steel. CF8M (316) investment casting. Seats: PTFE + 25% Graphite, stem o'ring: viton. Antistatic device. Max. pressure: 40/16 bar depending on size. Temp.: -30°C +250°C. manually operated by handle. L: DIN 3202 F-4 DN 15 DN 100 F-5 DN 125 DN 200.

MED.	PN	D	A	L	M	ISO 5211
1/2"	40	95	85	115	170	F04
3/4"	40	105	85	120	170	F04/F05
1"	40	116	95	125	170	F04/F05
1 1/4"	40	140	106	130	200	F05/F07
1 1/2"	40	150	110	140	200	F05/F07
2"	40	165	118	150	200	F05/F07
2 1/2"	16	185	157	170	380	F07/F10
3"	16	200	170	180	380	F07/F10
4"	16	220	184	190	380	F07/F10



Información técnica
Technical information

2528C 04	1/2"	2.149	139,61
2528C 05	3/4"	3	162,07
2528C 06	1"	3.83	201,25
2528C 07	1 1/4"	5.869	326,57
2528C 08	1 1/2"	6.85	358,93
2528C 09	2"	9.431	482,09
2528C 10	2 1/2"	15.036	772,57
2528C 11	3"	19.124	-
2528C 12	4"	26.665	1390,93

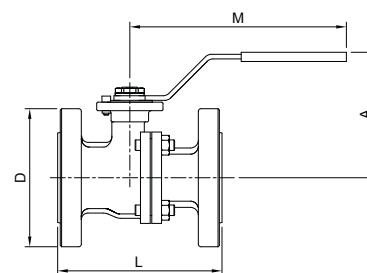

Ref.2528A



Válvula esfera paso total 2 piezas, bridas ANSI B-16.5 S-150; Certificación "FIRE SAFE" Montaje directo de actuadores S/ISO 5211. Cuerpo: inox. CF8M (316). Asientos: PTFE +15% FV. Presión máx.: 19 kg/cm2. Temp.: -30°C +180°C. Mando manual por palanca.

2 pcs full bore ball valve flanges ANSI B-16.5 s-150. FIRE SAFE Certification Direct mounting for actuators ISO 521. Body: stainless steel CF8M (316). Seats: PTFE + 15% GF. Max. pressure: 19 kg/cm2. Temp.: -30°C +180°C. Manually operated by handle.

MED.	DN	D	L	M	A	ISO 5211
1/2"	15	89	108	165	85	F04
3/4"	20	98,6	117	165	85	F04/F05
1"	25	108	127	200	95	F04/F05
1 1/4"	32	117	140	165	106	F05/F07
1 1/2"	40	127	165	200	110	F05/F07
2"	50	152,5	178	200	118	F05/F07
2 1/2"	65	177,8	190	380	157	F07/F10
3"	80	190,5	203	380	170	F07/F10
4"	100	228,6	229	380	184	F07/F10
6"	150	279,4	394	620	225	F10/F12
8"	200	342,9	457	800	330	F12



Información técnica
Technical information

CÓDIGO CODE	MEDIDA SIZE	PESO WEIGHT	P.V.P. € PRICE €
2528A 04	1/2"	1.522	102,73
2528A 05	3/4"	1.944	121,80
2528A 06	1"	2.698	163,07
2528A 07	1 1/4"	4.066	221,42
2528A 08	1 1/2"	5.483	289,40
2528A 09	2"	8.117	400,85
2528A 10	2 1/2"	15.051	643,28
2528A 11	3"	18.881	867,06
2528A 12	4"	30.468	1320,41
2528A 14	6"	56.23	3732,27
2528A 16	8"	129.225	8638,49

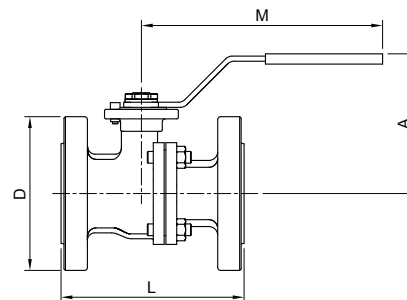

Ref.2528AC



Válvula esfera paso total 2 piezas bridas ANSI B-16.5 S-150, Certificación "FIRE SAFE" Montaje directo de actuadores S/ISO 5211. Cuerpo: inox. CF8M (316). Asientos: PTFE +25% Grafito. Presión máx.: 19 kg/cm2. Temp.: -30°C +250°C. Mando manual por palanca.

2 pcs full bore ball valve flanges ANSI B-16.5 s-150. FIRE SAFE Certification Direct mounting for actuators ISO 5211. Body: stainless steel CF8M (316). Seats: PTFE + 25% Graphite. Max. pressure: 19 kg/cm2. Temp.: -30°C +250°C. Manually operated by handle.

MED.	DN	D	L	M	A	ISO 5211
1/2"	15	89	108	165	85	F04
3/4"	20	98,6	117	165	85	F04/F05
1"	25	108	127	200	95	F04/F05
1 1/4"	32	117	140	165	106	F05/F07
1 1/2"	40	127	165	200	110	F05/F07
2"	50	152,5	178	200	118	F05/F07
2 1/2"	65	177,8	190	380	157	F07/F10
3"	80	190,5	203	380	170	F07/F10
4"	100	228,6	229	380	184	F07/F10



Información técnica
Technical information

2528AC 04	1/2"	1.518	118,14
2528AC 05	3/4"	1.956	140,08
2528AC 06	1"	2.706	187,53
2528AC 07	1 1/4"	4.042	254,62
2528AC 08	1 1/2"	5.472	332,80
2528AC 09	2"	8.078	460,98
2528AC 10	2 1/2"	14.947	739,76
2528AC 11	3"	18.779	997,12
2528AC 12	4"	30.4	1518,47

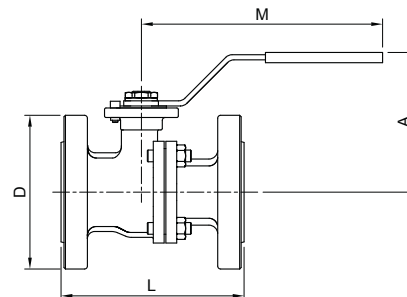

Ref.2529

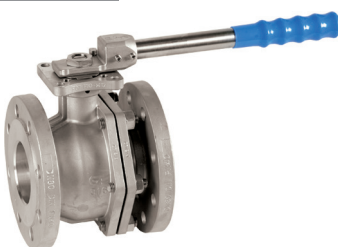

Válvula esfera paso total 2 piezas bridas DIN PN-40, Certificación "FIRE SAFE"

Montaje directo de actuadores según ISO 5211. Cuerpo: CF8M (316). Asientos y juntas: PTFE +15% FV. Tórica eje: vitón. Presión máx.: 40 bar. Temp.: -30°C +180°C. Mando manual por palanca. L: S/DIN 3202 F-4 DN 65 DN 100. F-5 DN 125 DN 200.

2 pcs. Full bore ball valve FIRE SAFE Certification

Direct mounting for actuators ISO 5211. Body: stainless steel. CF8M (316). Seats: PTFE + 15% GF. Stem o'ring: viton. Max. pressure: 40 bar. temp.: -30°C +180°C. Manually operated by handle. L: DIN 3202 F-4 DN 65 DN 100. F-5 DN 125 DN 200.

MED.	DN	L	D	A	M	ISO 5211
2 1/2"	65	170	185	157	380	F07/F10
3"	80	180	200	170	380	F07/F10
4"	100	190	235	184	380	F07/F10
5"	125	325	270	200	380	F10/F12
6"	150	350	300	350	450	F07/F10



Información técnica
Technical information

2529 10	2 1/2"	15.951	896,43
2529 11	3"	20.465	1151,32
2529 12	4"	29.394	1612,50
2529 13	5"	52	3468,09
2529 14	6"	71.45	4882,69

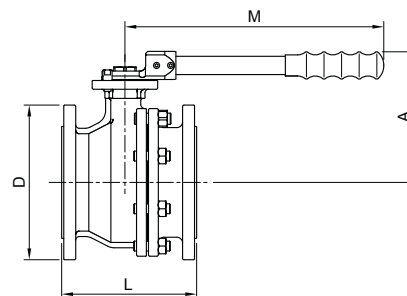

Ref. 2540E - 2541E



Válvula de esfera 3 vías paso total
2540E paso tipo "L" / 2541E paso tipo "T"
Bridas DIN PN 40 ≤ DN50
Bridas DIN PN 16 > DN50
 Montaje directo de actuadores s/ISO 5211.
 Cuerpo: inox CF8M (316). 4 asientos: PTFE + 15% FV.
 Presión máx. 16/40 bar según medida.
 Temp.: -30°C +180°C. Mando manual por palanca.

3 ways full bore ball valve
2540E "L" bore / 2541E "T" bore
Flanges DIN PN 40 ≤ DN50
Flanges DIN PN 16 > DN50

Direct mounting for actuators ISO 5211.
 Body: stainless steel CF8M (316). 4 seats: PTFE + 15% GF.
 Max. pressure: 16/40 bar depending on size.
 Temp.: -30°C +180°C. Manually operated by handle.



Información técnica
 Technical information

MED.	PN	P	D	L	M
1"	40	25	115	180	163
1 1/4"	40	32	140	190	209
1 1/2"	40	40	150	212	209
2"	40	50	165	230	209
2 1/2"	16	65	185	290	450
3"	16	80	200	310	500
4"	16	100	220	350	550

L				
T				

CÓDIGO CODE	MEDIDA SIZE	PESO WEIGHT	P.V.P. € PRICE €
----------------	----------------	----------------	---------------------

2540E / 2541E			
2540E 06	1"	7.365	455,15
2540E 07	1 1/4"	10.42	584,72
2540E 08	1 1/2"	14.295	729,80
2540E 09	2"	18.421	996,69
2540E 10	2 1/2"	27.257	1744,20
2540E 11	3"	40.232	2491,71
2540E 12	4"	59.753	3876,00

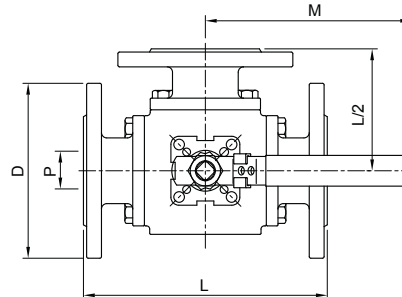

Ref. 2544 - 2545

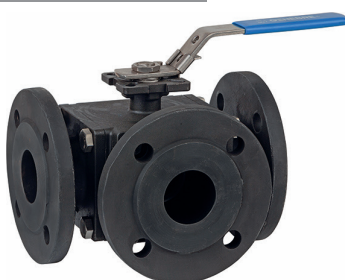

Válvula esfera 3 vías paso total. 2544 paso tipo "L" / 2545 paso tipo "T".
Bridas DIN PN40 ≤ DN50. Bridas DIN PN16 DN50.

3 way full bore ball valve. 2544 "L" bore / 2545 "T" bore.
Flanges DIN PN40 ≤ DN50. Flanges DIN PN16 DN50.

MED.	PN	P	D	L	M
1"	40	25	115	180	163
1 1/4"	40	32	140	190	209
1 1/2"	40	40	150	212	209
2"	40	50	165	230	209
2 1/2"	16	65	185	290	450
3"	16	80	200	310	500
4"	16	100	220	350	550

L				
T				



Información técnica
 Technical information

2544 / 2545			
-------------	--	--	--

2544 06	1"	7.22	327,52
2544 07	1 1/4"	10.415	411,83
2544 08	1 1/2"	14.285	506,79
2544 09	2"	18.555	701,56
2544 10	2 1/2"	27.48	1211,25
2544 11	3"	40.44	1719,98
2544 12	4"	60.225	2630,84

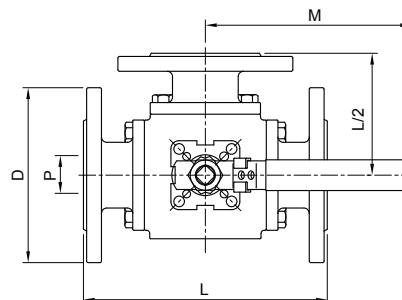

Ref. 2830 - 2830N



Manguito elástico - doble onda

Rosca gas, también disponible en rosca NPT (2830N). Cuerpo EPDM, extremos racors acero al carbono zincados. Roscas gas. Presión de trabajo máx.: 10 bar. Temp. -10°C +105°C. Longitud: 200 mm.

Rubber expansion joint-double wave

Gas thread, also available npt thread (2830N). Body EPDM. Zinc plated gas threaded ends. Max. working pressure: 10 bar. Temp. -10°C +105°C. Length: 200 mm.

MED.	L
3/4"	200
1"	200
1 1/4"	200
1 1/2"	200
2"	200
2 1/2"	245
3"	245



Información técnica
 Technical information

2830 05	3/4"	0.654	18,23
2830 06	1"	1.088	22,35
2830 07	1 1/4"	1.332	25,59
2830 08	1 1/2"	1.74	33,07
2830 09	2"	2.517	41,20
2830 10	2 1/2"	3.975	68,53
2830 11	3"	5.551	82,90

Precios rosca NPT a consultar / NPT thread prices on request

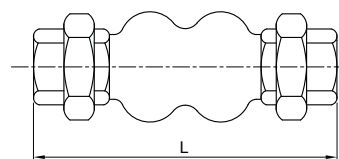

Ref.2831



Manguito elástico - simple onda

Cuerpo EPDM. Bridas DIN PN 10 acero al carbono zincadas. Presión de trabajo. Máx.: 10 bar. Temp: -10°C +105°C.

Rubber expansion - joint-single wave

Body: EPDM. Zinc plated DIN PN 10 Carbon steel flanges. Max. working pressure: 10 bar. Temp. -10°C +105°C.

DN	P	L	D	D1
32	40	95	140	69
40	40	95	150	69
50	52	105	165	86
65	68	115	185	106
80	76	130	200	116
100	103	135	220	150
125	128	170	250	180
150	152	180	285	209
200	194	195	340	260
250	250	240	395	320
300	300	260	445	367
350	320	265	505	408
400	372	255	565	472
450	415	255	615	522
500	454	255	670	570



Información técnica
Technical information

CÓDIGO CODE	MEDIDA SIZE	PESO WEIGHT	P.V.P. € PRICE €
2831 07	1 1/4"	2.995	30,04
2831 08	1 1/2"	3.545	31,92
2831 09	2"	4.281	40,27
2831 10	2 1/2"	5.21	51,30
2831 11	3"	6.443	62,55
2831 12	4"	6.996	78,28
2831 13	5"	9.603	105,32
2831 14	6"	13.111	129,83
2831 16	8"	17.31	194,84
2831 18	10"	23.182	329,97
2831 20	12"	27.839	416,78
2831 22	14"	37.764	492,36
2831 24	16"	43.879	577,82
2831 26	18"	46.8	658,01
2831 28	20"	57.818	813,23

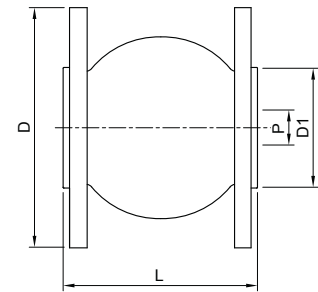

Ref.2831A



Manguito elástico bridasCuerpo EPDM. Bridas ANSI 150 lbs acero al carbono zincadas.Presión de trabajo máx.: 19 kg/cm2. Temp: -10°C +105°C.

Rubber expansion jointBody: EPDM. Zinc plated ANSI 150 lbs Carbon steel flanges. Max. working pressure: 19 kg/cm2. Temp.: -10°C +105°C.

275 Psi -14°F + 221°F

MED.	P	L	D	D1
1 1/4"	40	95	117,5	69
1 1/2"	40	95	127	69
2"	52	105	152,4	86
2 1/2"	68	115	177,8	106
3"	76	130	190,5	116
4"	103	135	228,6	150
5"	128	170	254	180
6"	152	180	279,4	209
8"	194	205	342,9	260
10"	250	240	406,4	320
12"	300	260	482,6	367
14"	320	255	533,4	408
16"	372	255	596,9	472
18"	415	255	635	522
20"	454	255	698,5	570



Información técnica
Technical information

CÓDIGO CODE	MEDIDA SIZE	PESO WEIGHT	P.V.P. € PRICE €
2831A 07	1 1/4"	1.914	31,07
2831A 08	1 1/2"	2.31	33,08
2831A 09	2"	3.314	41,29
2831A 10	2 1/2"	4.587	53,13
2831A 11	3"	5.752	63,58
2831A 12	4"	7.65	81,04
2831A 13	5"	9.575	109,08
2831A 14	6"	12.268	134,37
2831A 16	8"	17.752	203,54
2831A 18	10"	24.813	339,85
2831A 20	12"	37.385	437,49
2831A 22	14"	46.364	542,11
2831A 24	16"	55.638	643,49
2831A 26	18"	52.807	753,12
2831A 28	20"	69.114	926,60

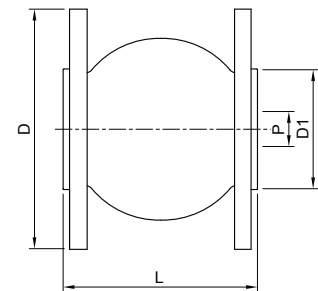

Ref.2833



Manguito elástico - doble onda EPDM
Cuerpo EPDM. Bridas DIN PN 10 acero al carbono zincadas.
Presión trabajo máx.: 10 bar. Temp.: -10°C +105°C

Rubber expansion joint-double wave EPDM
Body: EPDM, Zinc plated DIN PN 10 Carbon steel flanges.
Max. working pressure: 10 bar. Temp.: -10°C +105°C.

DN	P	L	D	D1
50	52	175	165	86
65	68	175	185	106
80	76	175	200	116
100	103	225	220	150
125	128	225	250	180
150	152	225	285	209
200	194	325	340	260
250	250	325	395	320
300	300	325	445	367



Información técnica
Technical information

CÓDIGO CODE	MEDIDA SIZE	PESO WEIGHT	P.V.P. € PRICE €
2833 09	2"	4.306	53,27
2833 10	2 1/2"	5.303	66,93
2833 11	3"	6.359	83,04
2833 12	4"	7.323	107,78
2833 13	5"	9.847	150,79
2833 14	6"	13.45	191,81
2833 16	8"	18.789	301,94
2833 18	10"	23.879	425,23
2833 20	12"	28.65	554,14

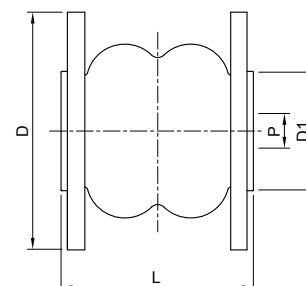

Ref.2834



Junta de expansión metálica con camisa interior
Extremos soldar, PN 10. Fuelle acero inox. AISI 304. Camisa interior acero inox. AISI 304. Extremos acero inox. AISI 304. Temp. máx.: 300°C.

Metal expansion joint with internal liner
Welded ends, PN 10. Internal liner bellows: stainless steel AISI 304. Stainless steel AISI 304 ends. Max. temp. 300°C.

MED.	L	Do	De
1 1/2"	200	52	48,3
2"	275	69	60,3
2 1/2"	275	88	76,1
3"	275	107	88,9
4"	300	140	114,3
5"	300	167	139,7
6"	350	199	168,3
8"	350	266	219,1



Información técnica
Technical information

2834 08	1 1/2"	0.8	162,66
2834 09	2"	1.638	180,04
2834 10	2 1/2"	2.019	232,60
2834 11	3"	2.515	250,03
2834 12	4"	3.867	310,43
2834 13	5"	5.45	370,73
2834 14	6"	7.2	456,59
2834 16	8"	10.275	783,96

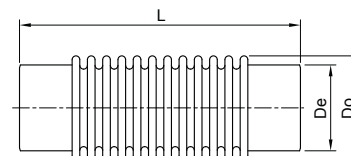

Ref.2835E

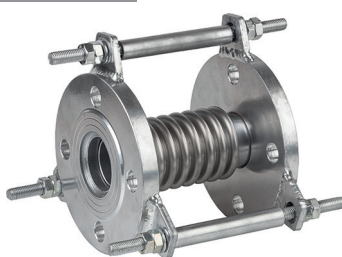

Junta de expansión metálica con camisa interior
Extremos bridas DIN PN 16. Fuelle acero inox. AISI 304. Camisa interior acero inox. AISI 304. Extremos bridas en acero carbono. Presión máx. trabajo: 16 bar. Temp. máx.: 300°C. Tirantes limitadores de movimiento para evitar roturas por exceso de compensación (a partir de 2").

Metal expansion joint with internal liner
Flanged ends DIN PN 16. Internal liner, bellows and ends: stainless steel AISI 304. Max. working pressure: 16 bar. Max. temp. 300°C. Limit rods are used to protect from movements in excess (from 2").

DN	L	Do	K	D
25	170	45	85	115
32	170	45	100	140
40	170	45	110	150
50	170	69	125	165
65	170	88	145	185
80	170	107	160	200
100	170	140	180	220
125	170	167	210	250
150	220	199	240	285
200	220	266	295	340



Información técnica
Technical information

2835E 06	1"	2.25	117,91
2835E 07	1 1/4"	3.355	136,00
2835E 08	1 1/2"	3.8	144,27
2835E 09	2"	6.1	174,74
2835E 10	2 1/2"	7.933	192,18
2835E 11	3"	8.58	218,12
2835E 12	4"	10.736	273,87
2835E 13	5"	14.817	350,00
2835E 14	6"	20.445	426,73
2835E 16	8"	25.25	635,68

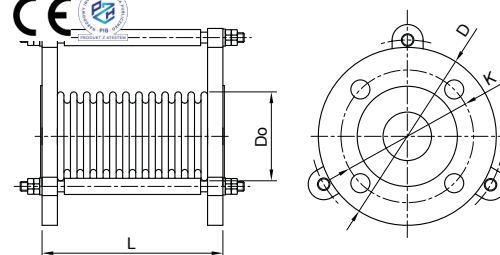

Ref.2835AE

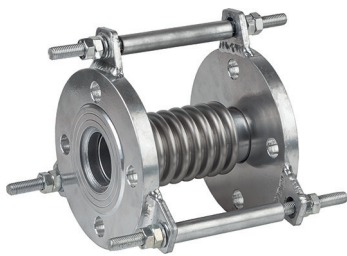

Junta de expansión metálica con camisa interior Extremos bridas ANSI 150lbs. Fuelle acero INOX, AISI 304. Camisa interior acero inox, AISI 304. Extremos bridas en acero carbono. Presión máx. trabajo: 19 kg/cm2. Temp. máx.: 300°C.

Metal expansion joint with internal liner Flanged ends carbon plated steel ANSI 150 lbs. Internal liner bellows: stainless steel AISI 304. Max. working pressure: 19 kg/cm2. Max. temp. 300°C.

MED.	L	Do	K	D
2"	170	69	120,6	152,4
2 1/2"	170	88	139,7	177,8
3"	170	107	152,4	190,5
4"	170	140	190,5	228,6
5"	170	167	215,4	254
6"	220	199	241,3	279,4
8"	220	266	298,4	342,9

CÓDIGO CODE	MEDIDA SIZE	PESO WEIGHT	P.V.P. € PRICE €
2835AE 09	2"	5.825	173,03
2835AE 10	2 1/2"	10.075	197,83
2835AE 11	3"	10.25	224,53
2835AE 12	4"	13.52	281,92
2835AE 13	5"	17.05	360,27
2835AE 14	6"	21.431	439,29
2835AE 16	8"	32.1	654,36

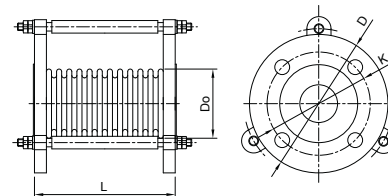

Información técnica
Technical information

Ref.2848

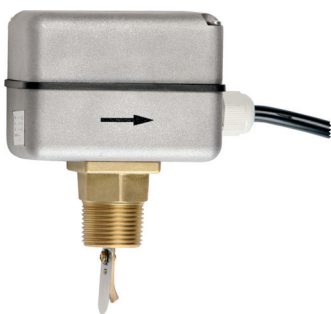

Controlador de caudal (líquidos)

Caja aleación aluminio. Racor latón. Lengüetas en acero inox incluidas de diferentes medidas para tuberías de 1" a 8". Conexión rosca 1" ISO 7/1 (EN 10226-1). Temp. máx. 110°C. Presión máx. 10 bar. 250V - 10A. Protección IP-64.

Liquid flow switch

Aluminium alloyed box. Brass connector. Including stainless steel blades in different sizes for pipes from 1" to 8". Threaded connection 1" ISO 7/1 (EN 10226-1). Max. temp. 110°C. Max. pressure 10 bar. 250V - 10A. Protection IP-64.

"Ø" TUBERÍA / PIPE	R	A	H	M	L
1" - 1 1/4"	1"	118	158	63	132
1 1/2" - 2"	1"	118	181	63	132
2 1/2" - 4"	1"	118	212	63	132
5" - 8"	1"	118	291	63	132

2848 06	1"	0.628	1-20	88,32
---------	----	-------	------	-------

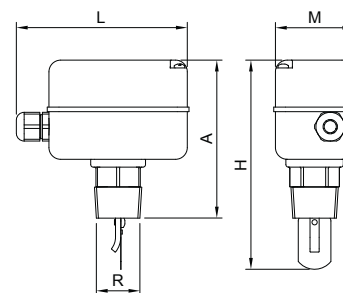

Información técnica
Technical information

Ref.2850



Controlador de caudal (líquidos)

Caja acero pintado. Racor latón. Lengüetas en acero inox incluidas de diferentes medidas para tuberías de 1" a 8". Conexión rosca 1" ISO 7/1 (EN 10226-1). Temp. máx. 110°C. Presión máx. 10 bar. 250V - 10A. Protección IP-54.

Liquid flow switch

Coated steel box. Brass connector. Including stainless steel blades in different sizes for pipes from 1" to 8". Threaded connection 1" ISO 7/1 (EN 10226-1). Max. temp. 110°C. Max. pressure 10 bar. 250V - 10A. Protection IP-54.

"Ø" TUBERÍA / PIPE	R	A	H	M	L
1" - 1 1/4"	1"	115	155	66	125
1 1/2" - 2"	1"	115	178	66	125
2 1/2" - 4"	1"	115	209	66	125
5" - 8"	1"	115	288	66	125

2850 06	1"	0.656	1-20	77,98
---------	----	-------	------	-------

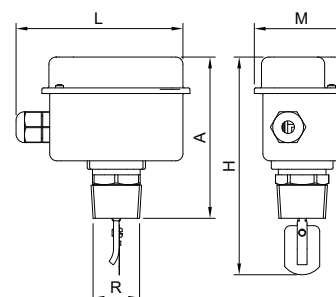

Información técnica
Technical information

Ref.3886

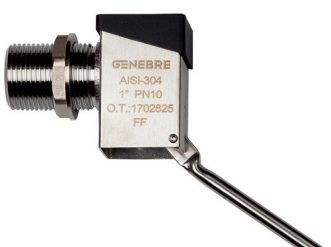

Válvula de flotador sin boyo

Construcción en acero inoxidable AISI 304. Conexión rosca gas. Paso total. Cierre de silicona progresivo. Presión de trabajo máxima 10 bar. Máx. temp. trabajo 150°.

Float valve without float

AISI 304 stainless steel construction. Gas thread connection. Full bore. Progressive silicone seal. Max. working pressure 10 bar. Max. working temp. 150°.

R	L	A
3/8"	300	32
1/2"	410	35
3/4"	500	42
1"	580	45
1 1/4"	580	52

3886 03	3/8"	0.104	1-24	21,39
3886 04	1/2"	0.18	2-24	23,00
3886 05	3/4"	0.31	1-20	39,47
3886 06	1"	0.385	1-15	42,48
3886 07	1 1/4"	0.465	1-15	49,04

* Cantidad mínima de venta Caja grande / * Minimum sale quantity Carton

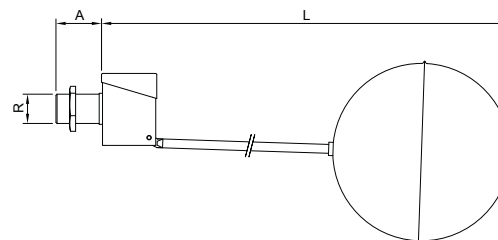

Información técnica
Technical information

Ref.3887



Boya para flotador

Construcción en acero inoxidable AISI 304.

Float buoy

AISI 304 stainless steel construction.

R	D	M
3/8"	90	M-6
1/2"	110	M-6
3/4"	160	M-8

CÓDIGO CODE	MEDIDA SIZE	PESO WEIGHT	CAJA / BOX CARTON	P.V.P. € PRICE €
----------------	----------------	----------------	----------------------	---------------------

3887 090	Ø 90 mm	0.066	1-48	16,66
3887 110	Ø 110 mm	0.093	1-30	19,65
3887 160	Ø 160 mm	0.318	1-12	42,76

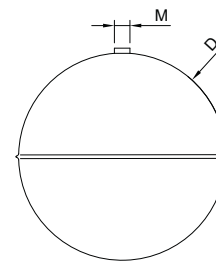

Información técnica
Technical information

Ref. 2856 - 2856N - 2856A



Válvula de flotador sin boya

Construcción: inox. AISI 316. Cierre silicona. Presión máx.: 10 bar.
Conexión: DN 10 - DN65: rosca gas ISO 228/1 y
DN80 - DN100: Brida EN 1092 PN 10/16

Floating valve

Constr. stainless steel AISI 316. Silicone sealing. Max. pressure: 10 bar.
Connection DN10 - DN65 gas ISO 228/1 thread
DN80 - DN100 flange EN 1092 PN 10/16

Válvula de flotador sin boya bridas ANSI

Floating valve flanges ends ANSI

MED.	L	A
3/8"	300	32
1/2"	410	35
3/4"	500	42
1"	580	45
1 1/4"	580	52
1 1/2"	620	60
2"	720	70
2 1/2"	720	80
3"	1110	105
4"	1160	105

2856 03	3/8"	0.2	20	105,64
2856 04	1/2"	0.327	1-52	123,06
2856 05	3/4"	0.565	1-30	167,75
2856 06	1"	0.62	1-15	243,50
2856 07	1 1/4"	0.762	1-10	273,70
2856 08	1 1/2"	2.664	1-8	460,90
2856 09	2"	2.994	1-6	573,81
2856 10	2 1/2"	3.521	1-6	769,27
2856 11	3"	15.161	-	2429,80
2856 12	4"	15.927	-	2706,30
2856A 11	3"	15.165	-	2551,29
2856A 12	4"	17.15	-	2841,61

Precios NPT a consultar / NPT thread prices on request

2856A 11	3"	15.165	-	2551,29
2856A 12	4"	17.15	-	2841,61

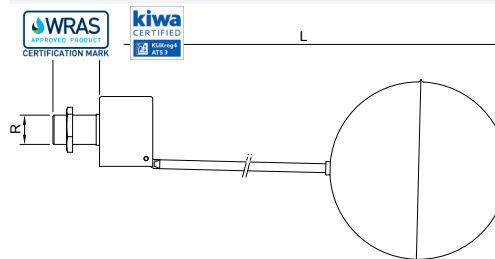

Información técnica
Technical information

Ref.2852



Boya para flotador - inox. 316

Buoy for floating valve stainless steel 316

MED.	D	M
3/8"	90	M-6
1/2"	110	M-6
3/4"	160	M-8
1 1/2"	200	M-12
3"	320	M16
4"	400	M-16

2852 060	-	0.062	24	39,99
2852 090	3/8"	0.15	30	57,75
2852 110	1/2"	0.149	1-30	75,97
2852 160	3/4" a 1 1/4"	0.398	1-12	101,17
2852 200	1 1/2" a 2 1/2"	0.792	1-8	153,38
2852 320	3"	3.276	1	536,54
2852 400	4"	4.762	1	658,77

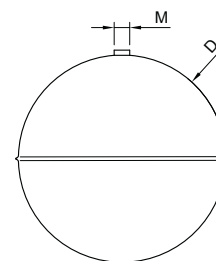

Información técnica
Technical information

Válvulas con esferas variable

Variable ball valves

Configuración de esfera en "V":
30°, 60°, 90°

Configuration of "V" ball: 30°, 60°, 90°



Ref.2015V



Válvula de control con esfera "V", 2 piezas

Características de válvula ver art. 2015.
Solicitar ángulo necesario 30°, 60° o 90°; ver extensión XX en cuadro.

"V" control ball valve, 2 pieces

Valve characteristics see art. 2015.
Indicate necessary angle 30°, 60° or 90°; see extension XX.

CÓDIGO CODE	MEDIDA SIZE	PESO WEIGHT	P.V.P. € PRICE €
XX= 30°/60°/90°			
2015V XX 04	-	0.455	71,37
2015V XX 05	-	0.566	85,74
2015V XX 06	-	0.735	97,54
2015V XX 07	-	1.352	145,56
2015V XX 08	-	1.937	184,57
2015V XX 09	-	2.916	269,20

XX= Indicar ángulo necesario / Indicate necessary angle



Información técnica
Technical information

Ref. 2025V - 2026V - 2027V



Válvula de control con esfera "V", 3 piezas

Características de válvula ver art. 2025/2026/2027.
Solicitar ángulo necesario 30°, 60° o 90°; ver extensión XX en cuadro.

"V" control ball valve, 3 pieces

Valve characteristics see art. 2025/2026/2027.
Indicate necessary angle 30°, 60° or 90°; see extension XX.

2025V / 2026V / 2027V			
2025V XX 04	XX= 30°/60°/90°	0.428	68,99
2025V XX 05	XX= 30°/60°/90°	0.835	86,28
2025V XX 06	XX= 30°/60°/90°	1.04	97,14
2025V XX 07	XX= 30°/60°/90°	1.88	152,45
2025V XX 08	XX= 30°/60°/90°	2.547	195,19
2025V XX 09	XX= 30°/60°/90°	3.7	278,53
2025V XX 10	XX= 30°/60°/90°	11.3	600,89
2025V XX 11	XX= 30°/60°/90°	13.077	899,37
2025V XX 12	XX= 30°/60°/90°	20.31	1397,79

XX= Indicar ángulo necesario / Indicate necessary angle



Información técnica
Technical information

Ref.2526AV

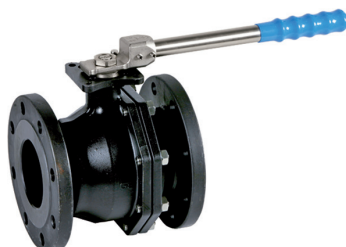

Válvula de control con esfera "V", 2 piezas bridas ANSI S-150

Características de válvula ver art. 2526A.
Solicitar ángulo necesario 30°, 60° o 90°; ver extensión XX en cuadro.

"V" control ball valve, 2 pieces flanges ends ANSI S-150

Valve characteristics see art. 2526A.
Indicate necessary angle 30°, 60° or 90°; see extension XX.

2526AV XX 04	XX= 30°/60°/90°	1.535	94,18
2526AV XX 05	XX= 30°/60°/90°	1.954	116,42
2526AV XX 06	XX= 30°/60°/90°	2.716	141,81
2526AV XX 07	XX= 30°/60°/90°	4.069	202,77
2526AV XX 08	XX= 30°/60°/90°	5.509	271,38
2526AV XX 09	XX= 30°/60°/90°	8.174	394,63
2526AV XX 10	XX= 30°/60°/90°	15.147	676,80
2526AV XX 11	XX= 30°/60°/90°	19.2	957,39
2526AV XX 12	XX= 30°/60°/90°	31.364	1585,80

XX= Indicar ángulo necesario / Indicate necessary angle



Información técnica
Technical information

Ref. 2528V

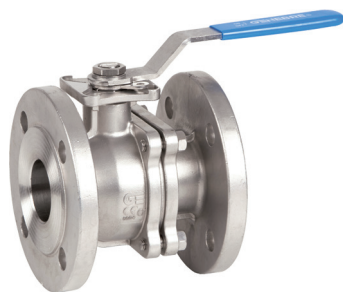

Válvula de control con esfera "V", 2 piezas bridas DIN PN 40/16

Características de válvula ver art. 2528.
Solicitar ángulo necesario 30°, 60° o 90°; ver extensión XX en cuadro.

"V" control ball valve, 2 pieces flanges ends DIN PN 40/16

Valve characteristics see art. 2528.
Indicate necessary angle 30°, 60° or 90°; see extension XX.

CÓDIGO CODE	MEDIDA SIZE	PESO WEIGHT	P.V.P. € PRICE €
2528V XX 04	XX= 30°/60°/90°	2.192	155,22
2528V XX 05	XX= 30°/60°/90°	3.025	178,17
2528V XX 06	XX= 30°/60°/90°	3.85	212,20
2528V XX 07	XX= 30°/60°/90°	5.877	316,15
2528V XX 08	XX= 30°/60°/90°	6.95	365,20
2528V XX 09	XX= 30°/60°/90°	9.571	494,14
2528V XX 10	XX= 30°/60°/90°	15.28	820,19
2528V XX 11	XX= 30°/60°/90°	19.471	1131,72
2528V XX 12	XX= 30°/60°/90°	27.419	1632,64

XX= Indicar ángulo necesario / Indicate necessary angle



Información técnica
Technical information

Ref. 2528AV



Válvula de control con esfera "V", 2 piezas bridas ANSI S-150

Características de válvula ver art. 2528A.
Solicitar ángulo necesario 30°, 60° o 90°; ver extensión XX en cuadro.

"V" control ball valve, 2 pieces flanges ends ANSI S-150

Valve characteristics see art. 2528A.
Indicate necessary angle 30°, 60° or 90°; see extension XX.

2528AV XX 04	XX= 30°/60°/90°	1.517	141,27
2528AV XX 05	XX= 30°/60°/90°	1.943	162,14
2528AV XX 06	XX= 30°/60°/90°	2.69	204,42
2528AV XX 07	XX= 30°/60°/90°	4.08	288,77
2528AV XX 08	XX= 30°/60°/90°	5.49	380,26
2528AV XX 09	XX= 30°/60°/90°	8.106	545,59
2528AV XX 10	XX= 30°/60°/90°	15.205	925,30
2528AV XX 11	XX= 30°/60°/90°	19.02	1256,64
2528AV XX 12	XX= 30°/60°/90°	31.364	1978,65

XX= Indicar ángulo necesario / Indicate necessary angle



Información técnica
Technical information

Extensor para válvula manual

Extension for manual valve



Ref.5330



Extensor para válvula manual (*)

(*) Válvula no incluida (consultar modelo de válvula)

Extension for manual valve (*)

(*) Valve not included (consult the model of the valve)

CÓDIGO CODE	MEDIDA SIZE	PESO WEIGHT	P.V.P. € PRICE €
----------------	----------------	----------------	---------------------

L = 50mm

5330 09 050	L=50 mm	0.131	75,77
5330 11 050	L= 50 mm	0.218	85,05
5330 14 050	L= 50mm	0.28	98,07
5330 15 050	L= 50mm	0.35	119,11
5330 17 050	L= 50mm	0.35	119,11
5330 20 050	L= 50 mm	0.35	119,11

Válvula no incluida / Valve not included

L = 100mm

5330 09 100	L= 100 mm	0.245	87,13
5330 11 100	L= 100mm	0.4	97,80
5330 14 100	L= 100mm	0.563	112,79
5330 15 100	L= 100mm	0.8	136,98
5330 17 100	L= 100mm	0.8	136,98
5330 20 100	L= 100 mm	0.8	136,98

Válvula no incluida / Valve not included

Válvulas roscar - soldar / Threaded - welded valves		
Ref.	ART.2015-2025;2026 - 2027	ART.2040-2041
5330 09 XXX	1/4" - 1/2"	1/4" - 1/2"
5330 11 XXX	3/4" - 1"	3/4" - 1"
5330 14 XXX	1 1/4" - 2"	1 1/4" - 2"
5330 17 XXX	2 1/2" - 4"	*****
5330 20 XXX	*****	2 1/2"

Válvulas bridadas / Flanged valves				
Ref.	ART.2118 - 2119	ART.2526A - 2528 - 2528A - 2529	ART.2525	ART.2540E - 2541E - 2544 - 2545
5330 09 XXX	1/2" - 3/4"	1/2" - 3/4"	1/2" - 3/4"	*****
5330 11 XXX	1" - 1 1/4"	1"	1" - 1 1/4"	1"
5330 14 XXX	1 1/2" - 2"	1 1/4" - 2"	1 1/2" - 2"	1 1/4" - 2"
5330 15 XXX	*****	*****	2 1/2" - 4"	*****
5330 17 XXX	*****	2 1/2" - 4"	*****	*****
5330 20 XXX	2 1/2" - 4"	*****	*****	2 1/2" - 4"



Información técnica
Technical information

Ref.5332



Extensor para válvula manual con sistema de bloqueo (*)

(*) Válvula no incluida (consultar modelo de válvula)

Extension for manual valve with locking system (*)

(*) Valve not included (consult the model of the valve)

L = 50mm

5332 09 050	L=50 mm	0.2	94,21
5332 11 050	L= 50 mm	0.45	104,44
5332 14 050	L= 50mm	0.78	118,77
5332 15 050	L= 50mm	0.35	143,57
5332 17 050	L= 50mm	0.01	143,57
5332 20 050	L= 50 mm	0.35	143,57

Válvula no incluida / Valve not included.

L = 100mm

5332 09 100	L= 100 mm	0.01	113,87
5332 11 100	L= 100mm	0.43	125,94
5332 14 100	L= 100mm	0.68	142,81
5332 15 100	L= 100mm	0.85	172,45
5332 17 100	L= 100mm	0.85	172,45
5332 20 100	L= 100 mm	0.85	172,45

Válvula no incluida / Valve not included.

Válvulas roscar - soldar / Threaded - welded valves		
Ref.	ART.2015 - 2025, 2026-2027	ART.2040-2041
5332 09 XXX	1/4" - 1/2"	1/4" - 1/2"
5332 11 XXX	3/4" - 1"	3/4" - 1"
5332 14 XXX	1 1/4" - 2"	1 1/4" - 2"
5332 17 XXX	2 1/2" - 4"	*****
5332 20 XXX	*****	2 1/2"

Válvulas bridadas / Flanged valves				
Ref.	ART.2118-2119	ART.2526A - 2528 - 2528A - 2529	ART.2525	ART.2540E - 2541E - 2544 - 2545
5332 09 XXX	1/2" - 3/4"	1/2" - 3/4"	1/2" - 3/4"	*****
5332 11 XXX	1" - 1 1/4"	1"	1" - 1 1/4"	1"
5332 14 XXX	1 1/2" - 2"	1 1/4" - 2"	1 1/2" - 2"	1 1/4" - 2"
5332 15 XXX	*****	*****	2 1/2" - 4"	*****
5332 17 XXX	*****	2 1/2" - 4"	*****	*****
5332 20 XXX	2 1/2" - 4"	*****	*****	2 1/2" - 4"



Información técnica
Technical information



GENEBRE
PARTNER IN FLUID CONTROL SOLUTIONS

02.





LÍNEA SANITARIA

Sanitary Line

Válvulas de esfera, retención, mariposa, grifos de nivel, toma muestras, para el sector alimentario, vitivinícola, farmacéutico

Ball valves, check valves, Butterfly valves, upper level cock and sampling valves for the food, wine, oil and pharmaceutical industries.

Válvulas de esfera / Ball valves	p. 75
Válvulas toma muestra / Sampling valves	p. 75
Válvulas de retención / Check valves	p. 76
Válvulas mariposa / Butterfly valves	p. 76
Válvulas diafragma / Diaphragm valves	p. 79
Accesorios línea sanitaria / Sanitary line accessories	p. 80
Automatización / Automation	p. 83

Ref.2918



Válvula de esfera acero inoxidable para bodega

PN 16. Paso red. Construcción en acero inox - AISI 316. Asientos PTFE. Entrada rosca gas (BSP) macho según ISO 228/1. Temp. máx. 110°C. Accionamiento mediante palomilla de acero inoxidable.

Stainless steel celler ball valve

PN 16. Reduced bore. Body stainless steel AISI 316. PTFE seats. Male gas threaded (BSP) inlet ISO 228/1. Max. temp. 110°C. Stainless steel butterfly handle operated.

R	A	L	M
3/8"	34	85	50
1/2"	34	85	50
3/4"	43	106	63

CÓDIGO CODE	MEDIDA SIZE	PESO WEIGHT	P.V.P. € PRICE €
2918 03	3/8"	0.17	26,51
2918 04	1/2"	0.159	26,51
2918 05	3/4"	0.353	39,79

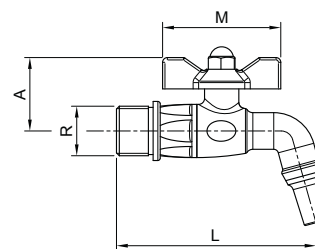

Información técnica
Technical information

Ref.2919



Válvula de esfera acero inoxidable para bodega

PN 16. Paso red. Construcción en acero inox - AISI 316. Entrada rosca cónica macho. Temp. máx. 110°C. Accionamiento mediante palomilla de acero inoxidable.

Stainless steel celler ball valve

PN 16. Reduced bore. Body stainless steel AISI 316. Male threaded conical inlet. Max. temp. 110°C. Stainless steel butterfly handle operated.

MED.	D	A	L	M
1/2"	18	34	85	50
3/4"	26	43	106	63

CÓDIGO CODE	MEDIDA SIZE	PESO WEIGHT	CAJA / BOX CARTON	P.V.P. € PRICE €
2919 04	1/2"	0.17	8-64	27,83
2919 05	3/4"	0.393	4-56	41,78

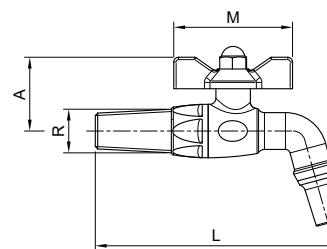

Información técnica
Technical information

Ref.2921



Grifo de nivel superior para manguera

Construcción en acero inoxidable AISI 304. Asiento PTFE. Conexión roscada 1/2" ISO 228/1. Espiga para manguera de 14 mm. Presión máxima de trabajo 10 bar.

Upper level cock with hose nipple

Stainless steel material AISI 304. Seat PTFE material. Thread end 1/2" ISO 228/1. Hose nipple dimension: 14 mm. Max. working pressure 10 bar.

MED.	R	A	L	E
1/2"	1/2" G	52	72	14

CÓDIGO CODE	MEDIDA SIZE	PESO WEIGHT	P.V.P. € PRICE €
2921 04	1/2"	0.262	37,01

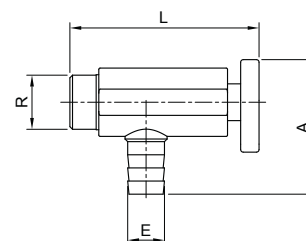

Información técnica
Technical information

Ref.2922



Grifo de nivel inferior para manguera con purga

Construcción en acero inoxidable AISI 304. Asiento PTFE. Conexión roscada 1/2" ISO 228/1. Espiga para manguera de 14 mm. Presión máxima de trabajo 10 bar.

Lower level cock with hose nipple and drain

Stainless steel material AISI 304. Seat PTFE material. Thread end 1/2" ISO 228/1. Hose nipple dimension: 14 mm. Max. working pressure 10 bar.

MED.	R	A	L	E
1/2"	1/2" G	88	72	14

CÓDIGO CODE	MEDIDA SIZE	PESO WEIGHT	P.V.P. € PRICE €
2922 04	1/2"	0.298	50,94

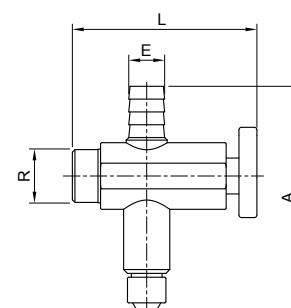

Información técnica
Technical information

CÓDIGO CODE	MEDIDA SIZE	PESO WEIGHT	P.V.P. € PRICE €
----------------	----------------	----------------	---------------------

Ref.2947



Válvula toma muestra tubo liso

Construcción en acero inoxidable AISI 304. Asiento PTFE. Conexión roscada 1/2" ISO 228/1. Presión máxima de trabajo 10 bar.

Sampling valve smooth pipe

Stainless steel material AISI 304. Seat PTFE material. Thread end 1/2" ISO 228/1. Max. working pressure 10 bar.

MED.	R	A	L
1/2"	1/2" G	55	72

2947 04	1/2"	0.236	36,04
---------	------	-------	-------

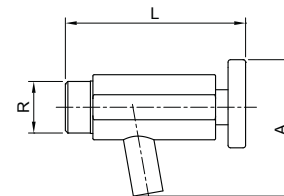

Información técnica
Technical information

Ref.2950



Válvula toma muestra con válvula inferior

Construcción en acero inoxidable AISI 304. Asiento PTFE. Conexión roscada 1/2" ISO 228/1. Presión máxima de trabajo 10 bar.

Sampling valve with lower valve

Stainless steel material AISI 304. Seat PTFE material. Thread end 1/2" ISO 228/1. Max. working pressure 10 bar.

MED.	R	A	L
1/2"	1/2" G	72	72

2950 04	1/2"	0.289	49,39
---------	------	-------	-------

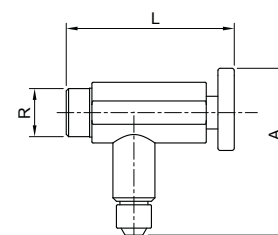

Información técnica
Technical information

Ref.2951



Válvula toma muestra extremo clamp

Cuerpo: acero inoxidable 316L. Cierre de silicona. Extremo clamp en pulgadas pulido sanitario. Presión máx. de trabajo: 10 bar.

Clamp end sampling valve

Body: stainless steel 316L. Silicone sealing. Clamp ends in inches. Sanitary polish. Max. working pressure: 10 bar.

MED.	A	B	C	D	E
1"-1 1/2"	91,5	70	50,5	29	12

2951 06	1"-1 1/2"	0.399	69,24
---------	-----------	-------	-------

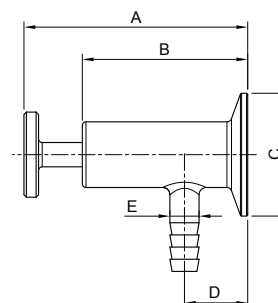

Información técnica
Technical information

Ref.2932



Válvula Esfera sanitaria extremo roscado/soldar

Construcción: acero inoxidable AISI 304. Extremos roscados DIN 11851 / Soldar. Asientos: PTFE, Junta: NBR. Presión máxima de trabajo: 10 bar. Temperatura máxima: 120°C. Accionamiento manual: 2 posiciones.

Sanitary ball valve end threaded/welded

Construction: stainless steel AISI 304. Threaded DIN 11851/welded end. Seats: PTFE, gasket: NBR. Maximum working pressure: 10 bar. Maximum temperature: 120°C. Manually operated: 2 position.

MED.	R	d	L	D	H	M
1"	52 x 1/6"	29	73	94	95	143
1 1/2"	65 x 1/6"	41	84	114	104	143
2"	78 x 1/6"	53	98	130	112	143
2 1/2"	95 x 1/6"	70	120	158	126	173
3"	110 x 1/4"	86	140	181	142	245

2932 06	1"	1.76	245,83
---------	----	------	--------

2932 08	1 1/2"	2.576	302,72
---------	--------	-------	--------

2932 09	2"	3.566	308,18
---------	----	-------	--------

2932 10	2 1/2"	6.923	417,07
---------	--------	-------	--------

2932 11	3"	9.34	587,06
---------	----	------	--------

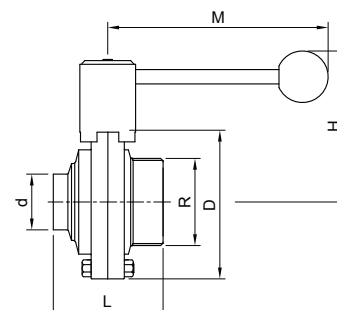

Información técnica
Technical information

Ref.2933



Válvula esfera 3 piezas extremos clamp

Const. acero inox. CF8M (316) microfusión. Asientos integrales y juntas eje: PTFE PN-25 (400 wog). Temp. -25°C +180°C. Mando manual por palanca con bloqueo de seguridad. Montaje directo S/ISO 5211.

3 pcs ball valve clamp ends

Stainless steel body CF8M (316). Investment casting integral seats and stem: PTFE PN-25 (400 wog). Temp: -25°C +180°C. Manually operated by handle with safety. Locking system. Direct mounting according ISO 5211.

MED.	B	C	E	H	I
1/2"	90	9,4	25,4	72	145
3/4"	90	15,6	25,4	77	145
1"	100	22,2	50,5	88	175
1 1/2"	125	35,6	50,5	105	190
2"	150	48,6	64	123	190
2 1/2"	190	60,3	77,5	150	260
3"	220	72,9	91	159	260
4"	270	97,6	119	198	400

CÓDIGO CODE	MEDIDA SIZE	PESO WEIGHT	P.V.P. € PRICE €
2933 04	1/2"	0.554	80,91
2933 05	3/4"	0.74	96,42
2933 06	1"	1.199	143,82
2933 08	1 1/2"	2.547	254,53
2933 09	2"	3.58	366,77
2933 10	2 1/2"	7.905	666,79
2933 11	3"	10.972	968,52
2933 12	4"	21.246	1825,10

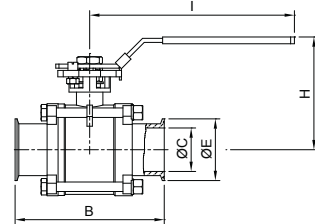

Información técnica
Technical information

Ref.2934

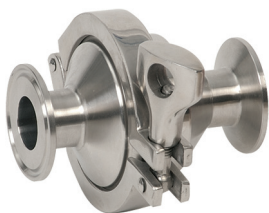

Válvula retención extremos clamp

Cuerpo: acero inox AISI 316L. Cierre EPDM - junta silicona. Extremos clamp en pulgadas. Pulido sanitario. Presión máx. de trabajo: 10 bar. Temp. máx. 120°C.

Check valve clamp ends

Stainless steel body 316L. EPDM sealing - silicone joint. Clamp ends in inches. Sanitary polish. Max. working pressure: 10 bar. Max. temp. 120°C.

MED.	A	B	C
1"	95,5	72	50,5
1 1/2"	97,5	87	50,5
2"	113,5	100	64
2 1/2"	119,5	115	77,5
3"	127,5	128	91
4"	151,5	164	119

2934 06	1"	0.767	160,35
2934 08	1 1/2"	0.939	175,28
2934 09	2"	1.331	226,30
2934 10	2 1/2"	1.731	329,91
2934 11	3"	2.256	495,30
2934 12	4"	3.53	694,97

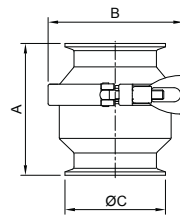

Información técnica
Technical information

Ref.2935



Válvula retención extremos soldar

Cuerpo: acero inox AISI 304. Cierre EPDM - junta silicona. Extremos soldar. Pulido sanitario. Presión máx. de trabajo: 10 bar. Temp. máx. 120°C.

Check valve welded end

Stainless steel body 304. EPDM sealing - silicone joint. Welded ends. Sanitary polish. Max. working pressure: 10 bar. Max. temp. 120°C.

DN	A	B	C	D
25	70	72	29	26
32	72	87	35	32
40	72	87	41	38
50	88	100	53	50
65	94	115	70	66
80	102	128	85	81
100	120	164	104	100

2935 06	DN 25	0.653	94,06
2935 07	DN 32	0.855	94,06
2935 08	DN 40	0.863	118,76
2935 09	DN 50	1.231	157,01
2935 10	DN 65	1.617	226,74
2935 11	DN 80	2.134	375,03
2935 12	DN 100	3.66	600,56

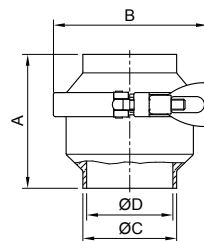

Información técnica
Technical information

Ref.2936



Válvula retención extremos roscar/soldar

Cuerpo: acero inox AISI 304. Cierre EPDM - junta silicona. Extremo: rosca DIN 11851 / soldar. Pulido sanitario. Presión máx. de trabajo: 10 bar. Temp. máx. 120°C.

Check valve end threaded/welded

Stainless steel body 304. EPDM sealing - silicone joint end threaded DIN 11851 / welded. Sanitary polish. Max. working pressure: 10 bar. Max. temp. 120°C.

DN	A	B	C	D	R
25	91	72	29	26	52 x 1/6"
32	93	87	35	32	58 x 1/6"
40	93	87	41	38	65 x 1/6"
50	110	100	53	50	78 x 1/6"
65	118	115	70	66	95 x 1/6"
80	128	128	85	81	110 x 1/4"
100	149	164	104	100	130 x 1/4"

2936 06	DN 25	0.764	114,00
2936 07	DN 32	0.98	114,00
2936 08	DN 40	1.018	129,97
2936 09	DN 50	1.432	167,47
2936 10	DN 65	1.929	235,56
2936 11	DN 80	2.517	407,72
2936 12	DN 100	5.78	616,92

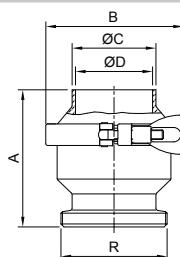

Información técnica
Technical information

Ref.2940



Válvula mariposa extremos clamp

Cuerpo acero inoxidable AISI 316L. Elastómero EPDM (otro material consultar). Extremos clamp en pulgadas. Pulido sanitario. Presión máx. de trabajo: 10 bar. Temp. máx.: 120°C. Accionamiento manual.

Butterfly valve clamp ends

Stainless steel body AISI 316L. EPDM elastomer (other material please consult us). Clamp ends in inches. Sanitary polish. Max. working pressure: 10 bar. Max. temp.: 120°C. Manually operated.

MED.	A	B	D	L	H
1"	66	78	50,5	130	82
1 1/2"	70	86	50,5	130	86
2"	76	102	64	140	96
2 1/2"	80	115	77,5	150	103
3"	84	128	91	150	110
4"	106	154	119	170	122

CÓDIGO CODE	MEDIDA SIZE	PESO WEIGHT	P.V.P. € PRICE €
2940 06	1"	1.293	127,12
2940 08	1 1/2"	1.27	138,65
2940 09	2"	1.806	175,08
2940 10	2 1/2"	2.221	238,27
2940 11	3"	2.618	279,04
2940 12	4"	3.407	377,92

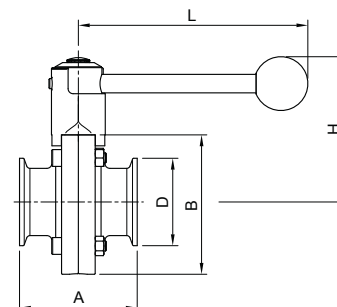

Información técnica
Technical information

Ref.2941E



Válvula mariposa extremos roscados

Cuerpo: acero inoxidable AISI 304. Elastómero: EPDM (otro material consultar). Extremos roscados DIN 11851. Presión máx. de trabajo: 10 bar. Temp. máx.: 120°C. Accionamiento manual: 3 posiciones.

Butterfly valve threaded ends

Stainless steel body AISI 304. EPDM elastomer (other material please consult us). Threaded ends DIN 11851. Max. working pressure 10 bar. Max. temp.: 120°C. Manually operated: 3 position.

MED.	DN	A	B	D	L	H
1"	25	66	78	52 x 1/6"	120	82
1 1/4"	32	70	86	58 x 1/6"	120	90
1 1/2"	40	74	90	65 x 1/6"	120	94
2"	50	76	106	78 x 1/6"	130	110
2 1/2"	65	84	124	95 x 1/6"	130	116
3"	80	90	139	110 x 1/4"	160	120
4"	100	108	159	130 x 1/4"	160	130

2941E 06	DN 25	1.325	86,26
2941E 07	DN 32	1.602	92,04
2941E 08	DN 40	1.732	103,58
2941E 09	DN 50	2.422	122,26
2941E 10	DN 65	3.036	153,53
2941E 11	DN 80	3.631	198,75
2941E 12	DN 100	5.059	300,66

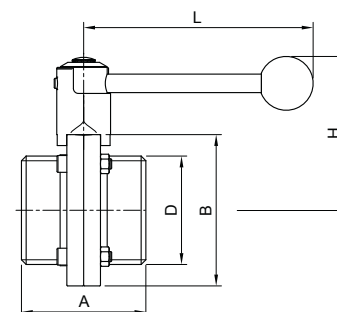

Información técnica
Technical information

Ref.2941EB



Válvula mariposa extremos roscados

Cuerpo: acero inoxidable AISI 304. Elastómero: NBR (otro material consultar). Extremos roscados DIN 11851. Presión máx. de trabajo: 10 bar. Temp. máx.: 120°C. Accionamiento manual: 3 posiciones.

Butterfly valve threaded ends

Stainless steel body AISI 304. NBR elastomer (other material please consult us). Threaded ends DIN 11851. Max. working pressure 10 bar. Max. temp.: 120°C. Manually operated: 3 position.

MED.	DN	A	B	D	L	H
1"	25	66	78	52 x 1/6"	120	82
1 1/4"	32	70	86	58 x 1/6"	120	90
1 1/2"	40	74	90	65 x 1/6"	120	94
2"	50	76	106	78 x 1/6"	130	110
2 1/2"	65	84	124	95 x 1/6"	130	116
3"	80	90	139	110 x 1/4"	160	120
4"	100	108	159	130 x 1/4"	160	130

2941EB 06	DN 25	1.325	93,16
2941EB 07	DN 32	1.602	-
2941EB 08	DN 40	1.732	111,87
2941EB 09	DN 50	2.422	132,05
2941EB 10	DN 65	3.036	165,82
2941EB 11	DN 80	3.631	214,65
2941EB 12	DN 100	5.059	-

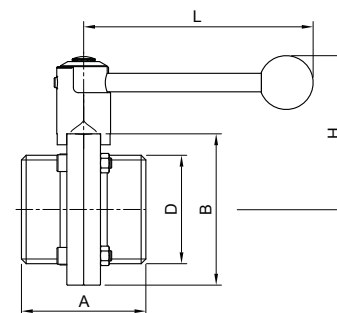

Información técnica
Technical information

Ref.2942E



Válvula mariposa extremo roscado/soldar

Cuerpo: acero inoxidable AISI 304. Elastómero: EPDM (otro material consultar). Extremos roscados DIN 11851/soldar. Presión máx. de trabajo 10 bar. Temp. máx.: 120°C. Accionamiento manual: 3 posiciones.

Butterfly valve end threaded/welded

Stainless steel body AISI 304. EPDM elastomer (other material please consult us). End threaded DIN 11851/welded. Max. working pressure 10 bar. Max. temp.: 120°C. Manually operated: 3 position.

MED.	DN	A	B	D	L	H
1"	25	58	78	52 x 1/6"	120	82
1 1/4"	32	60	86	58 x 1/6"	120	90
1 1/2"	40	62	90	65 x 1/6"	120	94
2"	50	64	106	78 x 1/6"	130	110
2 1/2"	65	70	124	95 x 1/6"	130	116
3"	80	75	139	110 x 1/4"	160	120
4"	100	86	159	130 x 1/4"	160	130

CÓDIGO CODE	MEDIDA SIZE	PESO WEIGHT	P.V.P. € PRICE €
2942E 06	DN 25	1.198	83,33
2942E 07	DN 32	1.436	92,30
2942E 08	DN 40	1.496	100,82
2942E 09	DN 50	2.105	116,77
2942E 10	DN 65	2.669	145,70
2942E 11	DN 80	3.15	192,32
2942E 12	DN 100	4.148	251,08

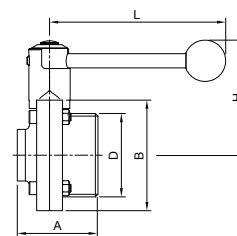

Información técnica
Technical information

Ref.2942EB



Válvula mariposa extremo roscado/soldar

Cuerpo: acero inoxidable AISI 304. Elastómero: NBR (otro material consultar). Extremos roscados DIN 11851/soldar. Presión máx. de trabajo 10 bar. Temp. máx.: 120°C. Accionamiento manual: 3 posiciones.

Butterfly valve end threaded/welded

Stainless steel body AISI 304. NBR elastomer (other material please consult us). End threaded DIN 11851/welded. Max. working pressure 10 bar. Max. temp.: 120°C. Manually operated: 3 position.

MED.	DN	A	B	D	L	H
1"	25	58	78	52 x 1/6"	120	82
1 1/4"	32	60	86	58 x 1/6"	120	90
1 1/2"	40	62	90	65 x 1/6"	120	94
2"	50	64	106	78 x 1/6"	130	110
2 1/2"	65	70	124	95 x 1/6"	130	116
3"	80	75	139	110 x 1/4"	160	120
4"	100	86	159	130 x 1/4"	160	130

2942EB 06	DN 25	1.2	90,00
2942EB 07	DN 32	1.449	99,68
2942EB 08	DN 40	1.507	108,89
2942EB 09	DN 50	2.116	126,11
2942EB 10	DN 65	2.659	157,36
2942EB 11	DN 80	3.15	207,71
2942EB 12	DN 100	4.133	271,17

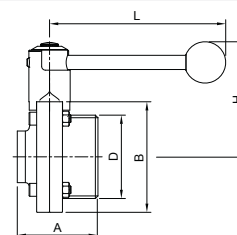

Información técnica
Technical information

Ref.2943E



Válvula mariposa extremo soldar/soldar

Cuerpo: acero inoxidable AISI 304. Elastómero: EPDM (otro material consultar). Extremos soldar/soldar. Presión máx. de trabajo 10 bar. Temp. máx. de 120°C. Accionamiento manual: 3 posiciones.

Butterfly valve end welded/welded

Stainless steel body AISI 304. EPDM elastomer (other material please consult us). End welded/welded. Max. working pressure 10 bar. Max. temp. 120°C. Manually operated: 3 position.

MED.	DN	A	B	D	L	H
1"	25	50	78	28	120	82
1 1/4"	32	50	86	34	120	90
1 1/2"	40	50	90	40	120	94
2"	50	52	106	52	130	110
2 1/2"	65	56	124	70	130	116
3"	80	60	139	85	160	120
4"	100	64	159	104	160	130

2943E 06	DN 25	1.068	78,93
2943E 07	DN 32	1.262	90,16
2943E 08	DN 40	1.262	96,05
2943E 09	DN 50	1.789	104,77
2943E 10	DN 65	2.267	127,85
2943E 11	DN 80	2.684	173,82
2943E 12	DN 100	3.2	210,20

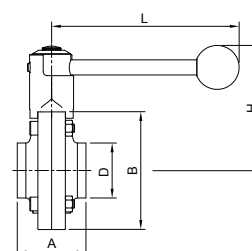

Información técnica
Technical information

Ref.2943EB



Válvula mariposa extremo soldar/soldar

Cuerpo: acero inoxidable AISI 304. Elastómero: NBR (otro material consultar). Extremos soldar/soldar. Presión máx. de trabajo 10 bar. Temp. máx. de 120°C. Accionamiento manual: 3 posiciones.

Butterfly valve end welded/welded

Stainless steel body AISI 304. NBR elastomer (other material please consult us). End welded/welded. Max. working pressure 10 bar. Max. temp. 120°C. Manually operated: 3 position.

MED.	DN	A	B	D	L	H
1"	25	50	78	28	120	82
1 1/4"	32	50	86	34	120	90
1 1/2"	40	50	90	40	120	94
2"	50	52	106	52	130	110
2 1/2"	65	56	124	70	130	116
3"	80	60	139	85	160	120
4"	100	64	159	104	160	130

2943EB 06	DN 25	1.09	85,25
2943EB 07	DN 32	1.279	97,38
2943EB 08	DN 40	1.271	103,74
2943EB 09	DN 50	1.788	113,15
2943EB 10	DN 65	2.278	138,08
2943EB 11	DN 80	2.713	187,73
2943EB 12	DN 100	3.238	227,01

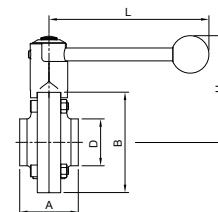

Información técnica
Technical information

Ref.2945



Válvula diafragma extremos clamp

Cuerpo acero inoxidable AISI 316L. Diafragma silicona (otro material consultar). Extremos: clamp en pulgadas. Pulido sanitario. Presión máx. de trabajo: 10 bar. Temp. máx.: 95°C. Accionamiento manual.

Diaphragm valve clamp ends

Stainless steel body AISI 316L. Silicone diaphragm. Clamp ends in inches. Sanitary polish. (ask for another material). Max. working pressure: 10 bar. Max. temp. max: 95°C. Manually operated.

MED.	A	B	F
1/2"	99,6	25,4	92/106
3/4"	99,6	25,4	92/106
1"	129	50,5	110/123
1 1/2"	159	50,5	139/159
2"	191	64	159/186

CÓDIGO CODE	MEDIDA SIZE	PESO WEIGHT	P.V.P. € PRICE €
2945 04	1/2"	0.692	121,49
2945 05	3/4"	0.608	114,19
2945 06	1"	0.952	132,15
2945 08	1 1/2"	1.54	198,17
2945 09	2"	2.355	297,24

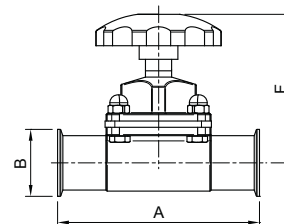

Información técnica
Technical information

Ref.2946

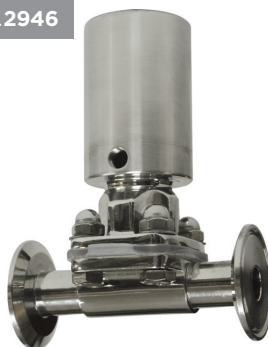

Válvula a diafragma extremos clamp accionamiento neumático simple efecto N.C.

Cuerpo válvula: acero inoxidable 316L (art. 2945). Cuerpo de actuador acero inoxidable 304. Extremos: clamp en pulgadas. Pulido sanitario. Accionamiento neumático a 5 bar.

Diaphragm valve clamp ends pneumatically operated. Spring return actuator N.C.

Body valve: stainless steel body 316L (art. 2945). Actuator: stainless steel body 304. Clamp ends in inches. Sanitary polish. Pneumatic operated at 5 bar.

MED.	A	B	C
1"	180	129	50,5
1 1/2"	220	159	50,5
2"	250	191	64

2946 06	1"	2.32	503,23
2946 08	1 1/2"	4.15	686,19
2946 09	2"	5.02	784,24

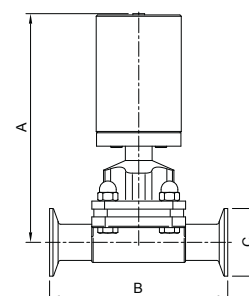

Información técnica
Technical information

Ref.2946E



Válvula a diafragma extremos clamp accionamiento neumático simple efecto N.C.

Cuerpo válvula: acero inoxidable 316L. Cuerpo de actuador acero inoxidable 304. Extremos: clamp en pulgadas. Pulido sanitario interno. Presión máx. de trabajo: 6bar. Temp. máx.: 130 °C. Accionamiento neumático 5-7 bar.

Diaphragm valve clamp ends pneumatically operated. Spring return actuator N.C.

Body valve: stainless steel body 316L. Actuator: stainless steel body 304. Clamp ends in inches. Internal sanitary polish. Max. working pressure: 6 bar. Max. temp: 130 °C. Pneumatic operated at 5-7 bar.

MED.	A	B	C
1"	165	127	50,5
1 1/2"	211	159	50,5
2"	225	190	64

2946E 06	1"	3.8	912,38
2946E 08	1 1/2"	7.275	1196,15
2946E 09	2"	8.6	1353,13

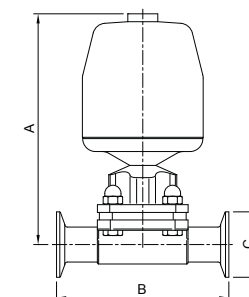

Información técnica
Technical information

Ref.2952



Esfera de limpieza

Cuerpo: acero inoxidable 316L. Extremo roscado ISO 7-1 (EN 10226-1). Ángulo de limpieza 360°. Pulido sanitario. Giro sobre rodamientos (2).

Cleaning ball

Body: stainless steel 316L. Threaded ends ISO 7-1 (EN 10226-1). Cleaning angle 360°. Sanitary polish. Double bearing (2).

MED.	DN	A	B	C	D
1"	25	146	52	1" BSP	22
1 1/2"	40	173	63	1 1/2" BSP	27
2"	50	202	75	2" BSP	34

2952 06	1"	0.321	90,77
2952 08	1 1/2"	0.651	169,74
2952 09	2"	0.958	259,78

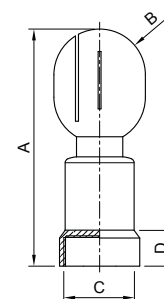

Información técnica
Technical information

Ref.2954



Tuerca roscada para racor soldar

Normativa aplicable: DIN 11851. Material: acero inoxidable 304. Terminación superficial: pulido.

Threaded ring for welded connector

Standards applied: DIN 11851. Stainless steel body AISI 304. Surface finishing ending: polish.

MED.	DN	A	B	C	D1
1/2"	15	18	44	25	34 x 1/8"
3/4"	20	20	54	31	44 x 1/6"
1"	25	21	63	36	52 x 1/6"
1 1/4"	32	21	70	42	58 x 1/6"
1 1/2"	40	21	78	49	65 x 1/6"
2"	50	22	92	62	78 x 1/6"
2 1/2"	65	25	112	80	95 x 1/6"
3"	80	29	127	94	110 x 1/4"
4"	100	31	148	115	130 x 1/4"

CÓDIGO CODE	MEDIDA SIZE	PESO WEIGHT	P.V.P. € PRICE €
2954 04	DN 15	0.087	12,71
2954 05	DN 20	0.123	12,71
2954 06	DN 25	0.183	12,71
2954 07	DN 32	0.218	12,75
2954 08	DN 40	0.259	12,75
2954 09	DN 50	0.365	16,27
2954 10	DN 65	0.523	23,15
2954 11	DN 80	0.678	30,63
2954 12	DN 100	0.99	44,51

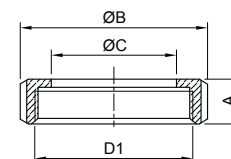

Información técnica
Technical information

Ref.2955



Conexión macho para soldar

Normativa aplicable: DIN 11851. Material: acero inoxidable 304. Terminación superficial: pulido.

Male connection for welding

Standards applied: DIN 11851. Stainless steel body AISI 304. Surface finishing: polish.

MED.	DN	A	B	C	D
1/2"	15	21	16	34 x 1/8"	21
3/4"	20	25	20	44 x 1/6"	24
1"	25	31	26	52 x 1/6"	29
1 1/4"	32	37	32	58 x 1/6"	32
1 1/2"	40	43	38	65 x 1/6"	33
2"	50	55	50	78 x 1/6"	35
2 1/2"	65	72	66	95 x 1/6"	40
3"	80	87	81	110 x 1/4"	45
4"	100	106	100	130 x 1/4"	54

CÓDIGO CODE	MEDIDA SIZE	PESO WEIGHT	P.V.P. € PRICE €
2955 04	DN 15	0.047	9,13
2955 05	DN 20	0.086	10,46
2955 06	DN 25	0.119	10,51
2955 07	DN 32	0.147	11,72
2955 08	DN 40	0.18	11,83
2955 09	DN 50	0.247	14,63
2955 10	DN 65	0.37	21,65
2955 11	DN 80	0.561	29,84
2955 12	DN 100	0.745	40,63

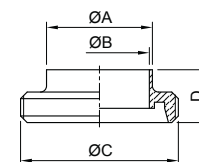

Información técnica
Technical information

Ref.2956



Casquillo para soldar

Normativa aplicable: DIN 11851. Material: acero inoxidable 304. Terminación superficial: pulido.

Clamp for welding

Standards applied: DIN 11851. Stainless steel body AISI 304. Surface finishing: polish.

MED.	DN	A	B	D	E
1/2"	15	16	21	28,5	17
3/4"	20	20	25	36,5	18
1"	25	26	31	44	22
1 1/4"	32	32	37	50	25
1 1/2"	40	38	43	56	26
2"	50	50	55	68,5	28
2 1/2"	65	66	72	86	32
3"	80	81	87	100	37
4"	100	100	106	121	44

CÓDIGO CODE	MEDIDA SIZE	PESO WEIGHT	P.V.P. € PRICE €
2956 04	DN 15	0.031	8,33
2956 05	DN 20	0.057	7,85
2956 06	DN 25	0.091	7,85
2956 07	DN 32	0.114	8,05
2956 08	DN 40	0.135	9,09
2956 09	DN 50	0.191	10,71
2956 10	DN 65	0.301	16,25
2956 11	DN 80	0.394	22,44
2956 12	DN 100	0.625	30,71

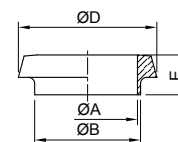

Información técnica
Technical information

Ref.2957



Junta para racor DIN 11851

Material: EPDM.

O'ring for DIN 11851 connector

Material: EPDM.

MED.	DN	A	B	C
1/2"	15	4,5	18	26
3/4"	20	4,5	23	33
1"	25	5	30	40
1 1/4"	32	5	36	46
1 1/2"	40	5	42	52
2"	50	5	54	64
2 1/2"	65	5	71	81
3"	80	5	85	95
4"	100	5	104	114

CÓDIGO CODE	MEDIDA SIZE	PESO WEIGHT	P.V.P. € PRICE €
2957 04	DN 15	0.002	0,62
2957 05	DN 20	0.002	0,61
2957 06	DN 25	0.003	0,61
2957 07	DN 32	0.003	0,67
2957 08	DN 40	0.004	0,91
2957 09	DN 50	0.005	1,25
2957 10	DN 65	0.006	1,57
2957 11	DN 80	0.007	2,14
2957 12	DN 100	0.011	2,43

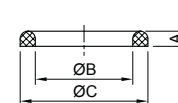

Información técnica
Technical information

Ref.2981



Casquillo para soldar clamp

Material acero inoxidable 316L. Clamp en pulgadas. Pulido sanitario.

Clamp welding socket

Stainless steel 316L. Clamp ends in inches sanitary polish.

MED.	C	L	A
1/2"	25,4	28,6	12,7
3/4"	25,4	28,6	19,05
1"	50,4	28,6	25,4
1 1/2"	50,4	28,6	38,1
2"	63,6	28,6	50,8
2 1/2"	77,5	28,6	63,5
3"	90,8	28,6	76,2
4"	118,5	28,6	101,6



Información técnica
Technical information

CÓDIGO CODE	MEDIDA SIZE	PESO WEIGHT	P.V.P. € PRICE €
2981 04	1/2"	0.024	11,12
2981 05	3/4"	0.025	11,12
2981 06	1"	0.083	11,44
2981 08	1 1/2"	0.067	11,77
2981 09	2"	0.091	12,64
2981 10	2 1/2"	0.118	16,89
2981 11	3"	0.144	20,79
2981 12	4"	0.243	29,79

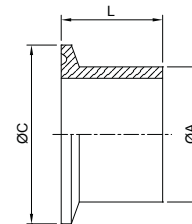

Ref.2982



Tapa ciega clamp

Material acero inoxidable 316L. Clamp en pulgadas. Pulido sanitario.

Clamp blind lid

Stainless steel 316L. Clamp ends in inches. Sanitary polish.

MED.	A	B
1/2"-3/4"	25,4	6,4
1"	50,5	6,4
1 1/2"	50,5	6,4
2"	64	6,4
2 1/2"	77,5	6,4
3"	91	6,4
4"	119	6,4



Información técnica
Technical information

2982 04	1/2"-3/4"	0.016	8,17
2982 06	1"	0.079	6,91
2982 08	1 1/2"	0.078	6,91
2982 09	2"	0.134	9,83
2982 10	2 1/2"	0.2	12,72
2982 11	3"	0.283	16,68
2982 12	4"	0.599	31,19

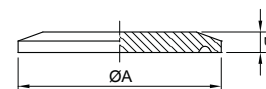

Ref.2983



Accesorios línea sanitaria codo 90° clamp

Material: acero inoxidable 316L. Clamp en pulgadas. Pulido sanitario.

Sanitary accessories clamp 90° elbow

Stainless steel 316L. Clamp ends in inches. Sanitary polish.

MED.	A	B	C
1/2"	25,4	9,5	41
3/4"	25,4	15,4	41
1"	50,5	22,4	55
1 1/2"	50,5	35,1	70
2"	64	47,8	82
2 1/2"	77,5	59,5	105
3"	91	72,2	110
4"	119	97,6	148



Información técnica
Technical information

2983 04	1/2"	0.054	42,36
2983 05	3/4"	0.056	42,36
2983 06	1"	0.18	31,91
2983 08	1 1/2"	0.192	38,84
2983 09	2"	0.319	48,66
2983 10	2 1/2"	0.63	73,29
2983 11	3"	0.75	92,37
2983 12	4"	1.383	152,46

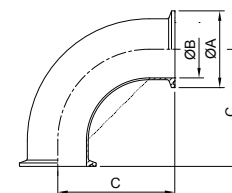

Ref.2984



Accesorios línea sanitaria codo 45° clamp

Material: acero inoxidable 316L. Clamp en pulgadas. Pulido sanitario.

Sanitary accessories clamp 45° elbow

Stainless steel 316L. Clamp ends in inches. Sanitary polish.

MED.	A	B
1"	50,5	35,5
1 1/2"	50,5	41,6
2"	64	46,6
2 1/2"	77,5	56
3"	91	58
4"	119	81



Información técnica
Technical information

2984 06	1"	0.153	31,91
2984 08	1 1/2"	0.14	38,84
2984 09	2"	0.223	48,66
2984 10	2 1/2"	0.339	73,29
2984 11	3"	0.459	92,37
2984 12	4"	1.03	152,46

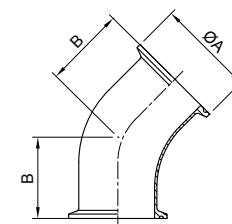

Ref.2985



Accesorios línea sanitaria "T" clamp

Material: acero inoxidable 316L. Clamp en pulgadas. Pulido sanitario.

Sanitary accessories "T" clamp

Stainless steel 316L. Clamp ends in inches. Sanitary polish.

MED.	A	B	C
1/2"	25,4	9,5	57
3/4"	25,4	15,4	60
1"	50,5	22,4	55
1 1/2"	50,5	35,1	70
2"	64	47,8	82
2 1/2"	77,5	59,5	105
3"	91	72,2	110
4"	119	97,6	148

CÓDIGO CODE	MEDIDA SIZE	PESO WEIGHT	P.V.P. € PRICE €
2985 04	1/2"	0.108	56,73
2985 05	3/4"	0.122	56,73
2985 06	1"	0.281	46,23
2985 08	1 1/2"	0.303	51,97
2985 09	2"	0.491	70,85
2985 10	2 1/2"	0.94	96,14
2985 11	3"	1.19	119,19
2985 12	4"	2.21	203,35

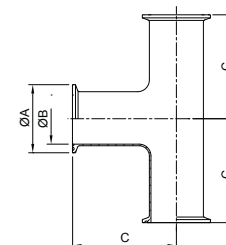

Información técnica
Technical information

Ref.2986



Abrazadera cierre rápido clamp

Material acero inoxidable 304. Aplicación clamp en pulgadas. Pulido sanitario.

Quick locking binding clamp

Stainless steel 304. Clamp ends in inches. Sanitary polish.

MED.	C	A
1/2"-3/4"	28,2	57,5
1"-1/2"	53,6	83
2"	67	95,7
2 1/2"	80,6	109,8
3"	94,2	123,1
4"	122,1	151,8

2986 04	1/2"-3/4"	0.119	12,63
2986 06	1"-1 1/2"	0.16	13,14
2986 09	2"	0.218	16,06
2986 10	2 1/2"	0.266	18,47
2986 11	3"	0.301	20,42
2986 12	4"	0.403	24,65

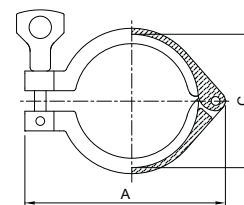

Información técnica
Technical information

Ref.2987



Junta para extremos clamp

Material silicona. Aplicación clamp en pulgadas.

Clamp ends joint

Silicone body. Clamp ends in inches.

MED.	D	C	E
1/2"	9,5	22	4,5
3/4"	15,9	22	4,5
1"	22,2	50,4	5,5
1 1/2"	35	50,4	5,5
2"	47,6	63,6	5,5
2 1/2"	60,2	77,5	5,5
3"	73	90,8	5,5
4"	97,4	118,5	5,5

2987 04	1/2"	0.001	0,98
2987 05	3/4"	0.001	1,19
2987 06	1"	0.005	1,19
2987 08	1 1/2"	0.003	1,19
2987 09	2"	0.005	1,56
2987 10	2 1/2"	0.006	1,96
2987 11	3"	0.008	2,39
2987 12	4"	0.012	2,97

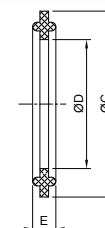

Información técnica
Technical information

Ref.2988



Reducción concéntrica clamp

Material: acero inoxidable 316L. Clamp en pulgadas. Pulido sanitario.

Concentric clamp reduction

Stainless steel 316L. Clamp in inches. Sanitary polish.

MED.	A	B	C
1 1/2" x 1"	76	50,5	50,5
2" x 1"	127	64	50,5
2" x 1 1/2"	76	64	50,5
2 1/2" x 1 1/2"	127	77,5	50,5
2 1/2" x 2"	76	77,5	64
3" x 2"	127	91	64
3" x 2 1/2"	76	91	77,5
4" x 3"	130	119	91

2988 08 06	1 1/2" x 1"	0.167	32,06
2988 09 06	2" x 1"	0.296	44,73
2988 09 08	2" x 1 1/2"	0.189	44,73
2988 10 08	2 1/2" x 1 1/2"	0.36	60,28
2988 10 09	2 1/2" x 2"	0.258	60,28
2988 11 09	3" x 2"	0.432	73,93
2988 11 10	3" x 2 1/2"	0.309	73,93
2988 12 11	4" x 3"	0.712	118,61

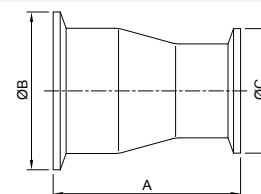

Información técnica
Technical information

Ref.5940



Válvula mariposa extremos clamp con actador inoxidable

Características de válvula ver art. 2940.
Características de actuador ver art. 2944/2949.
Actuador simple efecto o doble efecto.

Butterfly valve clamp ends with inox actuator.

Valve characteristics see art. 2940.
Actuator characteristics see art. 2944/2949.
Spring return or double acting actuator.

MED.	A	B
1"	232	85
1 1/2"	236	85
2"	240	85
2 1/2"	249	85
3"	255	85
4"	269	85

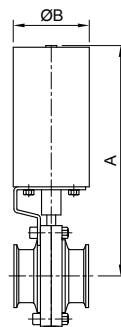

CÓDIGO CODE	MEDIDA SIZE	PESO WEIGHT	P.V.P. € PRICE €
-------------	-------------	-------------	------------------

Simple efecto / Spring return			
5940 06 44	1"	4	591,27
5940 08 44	1 1/2"	5.12	595,02
5940 09 44	2"	4.5	634,98
5940 10 44	2 1/2"	4.9	694,79
5940 11 44	3"	5.25	744,11
5940 12 44	4"	6.25	866,57
Doble efecto / Double acting			
5940 06 49	1"	4	591,27
5940 08 49	1 1/2"	4	595,02
5940 09 49	2"	4.5	634,98
5940 10 49	2 1/2"	5.44	694,79
5940 11 49	3"	5.25	744,11
5940 12 49	4"	7	866,57



Información técnica
Technical information

Ref.5941E



Válvula mariposa extremos roscados

Características de válvula ver art. 2941E.
Características de actuador ver art. 2944/2949.
Actuador simple efecto o doble efecto.

Butterfly valve threaded ends

Valve characteristics see art. 2941E.
Actuator characteristics see art. 2944/2949.
Spring return or double acting actuator.

MED.	DN	A	B
1"	25	232	85
1 1/4"	32	236	85
1 1/2"	40	238	85
2"	50	246	85
2 1/2"	65	253	85
3"	80	260	85
4"	100	271	85

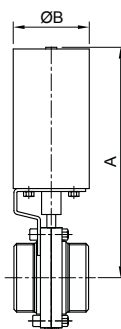

Simple efecto / Spring return			
5941E 06 44	1"	5	560,34
5941E 07 44	1 1/4"	5.3	579,18
5941E 08 44	1 1/2"	4.4	580,55
5941E 09 44	2"	5.1	603,46
5941E 10 44	2 1/2"	5.85	643,32
5941E 11 44	3"	6.5	684,93
5941E 12 44	4"	8.1	807,60
Doble efecto / Double acting			
5941E 06 49	1"	3.609	560,34
5941E 07 49	1 1/4"	3.709	579,18
5941E 08 49	1 1/2"	4.1	580,55
5941E 09 49	2"	4.8	603,46
5941E 10 49	2 1/2"	5.5	643,32
5941E 11 49	3"	6.1	684,93
5941E 12 49	4"	8.1	807,60



Información técnica
Technical information

Ref.5942E



Válvula mariposa extremos roscados/soldar

Características de válvula ver art. 2942E.
Características de actuador ver art. 2944/2949.
Actuador simple efecto o doble efecto.

Butterfly valve end threaded/welded

Valve characteristics see art. 2942E.
Actuator characteristics see art. 2944/2949.
Spring return or double acting actuator.

MED.	DN	A	B
1"	25	232	85
1 1/4"	32	236	85
1 1/2"	40	238	85
2"	50	246	85
2 1/2"	65	253	85
3"	80	260	85
4"	100	271	85

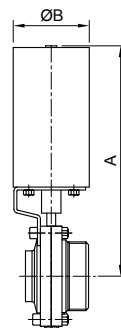

Simple efecto / Spring return			
5942E 06 44	1"	3.93	554,16
5942E 07 44	1 1/4"	3.9	563,79
5942E 08 44	1 1/2"	4.13	568,34
5942E 09 44	2"	4.73	592,98
5942E 10 44	2 1/2"	5.35	625,00
5942E 11 44	3"	5.8	657,98
5942E 12 44	4"	6.9	747,05
Doble efecto / Double acting			
5942E 06 49	1"	0.01	554,16
5942E 07 49	1 1/4"	0.01	563,79
5942E 08 49	1 1/2"	0.01	568,34
5942E 09 49	2"	0.01	592,98
5942E 10 49	2 1/2"	0.01	625,00
5942E 11 49	3"	0.01	657,98
5942E 12 49	4"	0.01	747,05



Información técnica
Technical information

Ref.5943E



Válvula mariposa extremos soldar/soldar

Características de válvula ver art. 2943E.
Características de actuador ver art. 2944/2949.
Actuador simple efecto o doble efecto.

Butterfly valve end welded/welded

Valve characteristics see art. 2943E.
Actuator characteristics see art. 2944/2949.
Spring return or double acting actuator.

MED.	DN	A	B
1"	25	232	85
1 1/4"	32	236	85
1 1/2"	40	238	85
2"	50	246	85
2 1/2"	65	253	85
3"	80	260	85
4"	100	271	85

CÓDIGO CODE	MEDIDA SIZE	PESO WEIGHT	P.V.P. € PRICE €
----------------	----------------	----------------	---------------------

Simple efecto / Spring return

5943E 06 44	1"	4.9	547,99
5943E 07 44	1 1/4"	3.93	548,35
5943E 08 44	1 1/2"	3.94	556,12
5943E 09 44	2"	4.35	582,52
5943E 10 44	2 1/2"	4.75	606,57
5943E 11 44	3"	5.05	631,03
5943E 12 44	4"	5.7	686,59

Doble efecto / Double acting

5943E 06 49	1"	0.01	547,99
5943E 07 49	1 1/4"	0.01	548,35
5943E 08 49	1 1/2"	0.01	556,12
5943E 09 49	2"	0.01	582,52
5943E 10 49	2 1/2"	0.01	606,57
5943E 11 49	3"	5.05	631,03
5943E 12 49	4"	0.01	686,59

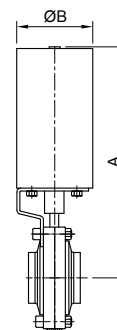

02 LÍNEA SANITARIA
SANITARY LINE



Información técnica
Technical information

Ref.5013



Válvula esfera 3 piezas (clamp)

Características de válvula ver art. 2933.

3 pieces ball valve (clamp)

Valve characteristics see art. 2933.

GNP						
MED.	MOD. ACT	A	E	L	D	
1/2"	GNP-14	145	90	122	65	
3/4"	GNP-14	151	90	122	65	
1"	GNP-14	174	90	122	65	
1 1/2"	GNP-44	212,5	117,5	168	83	
2"	GNP-44	227,5	117,5	168	83	
2 1/2"	GNP-94	278,5	138,5	204	103	
3"	GNP-94	292,5	138,5	204	103	
4"	GNP-198	362	163	268	121,5	

GNP						
MED.	MOD. ACT	A	E	L	D	
1/2"	GNP-24/S4	157	102	147	71,5	
3/4"	GNP-44/S4	178,5	117,5	168	83	
1"	GNP-44/S5	201,5	117,5	168	83	
1 1/2"	GNP-94/S5	233,5	138,5	204	103	
2"	GNP-135/S5	257	147	262	108,5	
2 1/2"	GNP-198/S4	302	103	268	121,5	
3"	GNP-300/S5	338	185	296	142	
4"	GNP-513/S5	400,5	201,5	390	152	

CÓDIGO CODE	MEDIDA SIZE	TIPO ACT. ACT. TYPE	PESO WEIGHT	P.V.P. € PRICE €
----------------	----------------	------------------------	----------------	---------------------

GNP Doble efecto / GNP Double acting

5013 04 122	1/2"	GNP-14	1.624	178,01
5013 05 122	3/4"	GNP-14	0.001	183,01
5013 06 122	1"	GNP-14	2.31	223,61
5013 08 128	1 1/2"	GNP-44	5.05	357,28
5013 09 128	2"	GNP-44	6.5	452,56
5013 10 142	2 1/2"	GNP-94	13.06	754,89
5013 11 142	3"	GNP-94	14.06	1013,36
5013 12 150	4"	GNP-198	26	1864,57

GNP Simple efecto / GNP Spring return

5013 04 126	1/2"	GNP-24/S5	2.24	206,60
5013 05 134	3/4"	GNP-44/S4	3.83	246,03
5013 06 136	1"	GNP-44/S5	3.84	279,02
5013 08 144	1 1/2"	GNP-94/S5	7.08	459,30
5013 09 148	2"	GNP-135/S5	10.4	590,91
5013 10 152	2 1/2"	GNP-198/S4	15.1	909,03
5013 11 160	3"	GNP-300/S5	31.88	1278,81
5013 12 164	4"	GNP-513/S5	43.08	2220,28

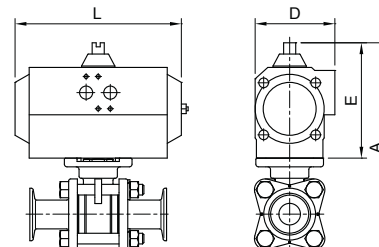

Información técnica
Technical information

Ref.5032

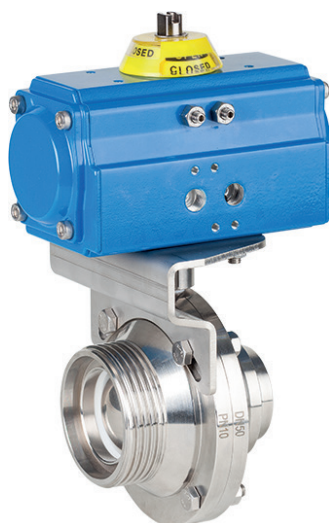

Válvula de esfera extremos roscados/soldar

Características de válvula ver art. 2932.

Ball valve threaded/welded end

Valve characteristics see art. 2932.

GNP					
MED.	MOD. ACT	A	E	L	D
1"	GNP-14	210	90	122	65
1 1/2"	GNP-44	253,5	117,5	168	83
2"	GNP-44	279,5	117,5	168	83
2 1/2"	GNP-94	330,5	138,5	204	103
3"	GNP-94	353,5	138,5	204	103

GNP					
MED.	MOD. ACT	A	E	L	D
1"	GNP-44/S5	237,5	117,5	168	83
1 1/2"	GNP-94/S5	274,5	138,5	204	103
2"	GNP-135/S5	309	147	262	108
2 1/2"	GNP-198/S4	355	163	268	121,5
3"	GNP-300/S5	400	185	296	142

CÓDIGO CODE	MEDIDA SIZE	TIPO ACT. ACT. TYPE	PESO WEIGHT	P.V.P. € PRICE €
----------------	----------------	------------------------	----------------	---------------------

GNP Doble efecto / GNP Double acting				
5032 06 122	1"	GNP-14	3.49	341,01
5032 08 128	1 1/2"	GNP-44	4.9	386,21
5032 09 128	2"	GNP-44	5.87	444,64
5032 10 142	2 1/2"	GNP-94	9.94	552,03
5032 11 142	3"	GNP-94	2	714,53
GNP Simple efecto / GNP Spring return				
5032 06 136	1"	GNP-44/S5	4.3	365,82
5032 08 144	1 1/2"	GNP-94/S5	6.93	473,01
5032 09 148	2"	GNP-135/S5	9.77	513,04
5032 10 152	2 1/2"	GNP-198/S4	11.98	620,43
5032 11 160	3"	GNP-300/S5	20	803,70

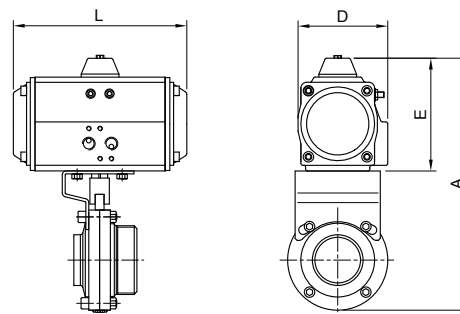

Información técnica
Technical information

02 LÍNEA SANITARIA
SANITARY LINE

Ref.5940

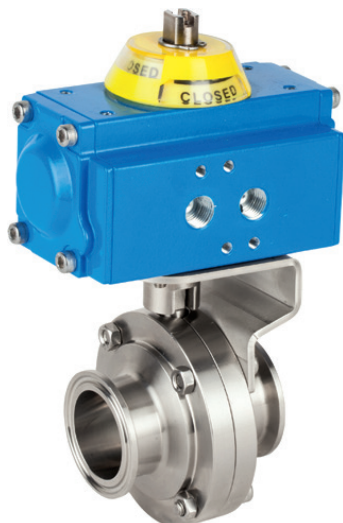

Válvula mariposa extremos clamp con actuador GNP

Características de válvula ver art. 2940.

Butterfly valve clamp ends with GNP actuator

Valve characteristics see art. 2940.

GNP					
MED.	MOD. ACT	A	E	L	D
1"	GNP-14	194	90	122	65
1 1/2"	GNP-14	202	90	122	65
2"	GNP-14	224	90	122	65
2 1/2"	GNP-24	249	102	147	72
3"	GNP-24	263	102	147	72
4"	GNP-44	308	118	168	83

GNP					
MED.	MOD. ACT	A	E	L	D
1"	GNP-24/S4	206	102	147	72
1 1/2"	GNP-24/S4	214	102	147	72
2"	GNP-44/S4	252	118	168	83
2 1/2"	GNP-60/S5	277	130	184	95
3"	GNP-60/S5	291	130	184	95
4"	GNP-94/S5	329	139	204	103

GNP Doble efecto / GNP Double acting				
5940 06 122	1"	GNP-14	2.4	264,85
5940 08 122	1 1/2"	GNP-14	2.2	275,03
5940 09 122	2"	GNP-14	3.06	309,39
5940 10 125	2 1/2"	GNP-24	3.63	382,96
5940 11 125	3"	GNP-24	4.8	430,25
5940 12 128	4"	GNP-44	5.63	530,00
GNP Simple efecto / GNP Spring return				
5940 06 126	1"	GNP-24/S4	2.8	289,65
5940 08 126	1 1/2"	GNP-24/S4	3.8	299,83
5940 09 134	2"	GNP-44/S4	3.9	395,59
5940 10 140	2 1/2"	GNP-60/S5	5.15	451,35
5940 11 140	3"	GNP-60/S5	5.6	498,63
5940 12 144	4"	GNP-94/S5	7.2	619,17

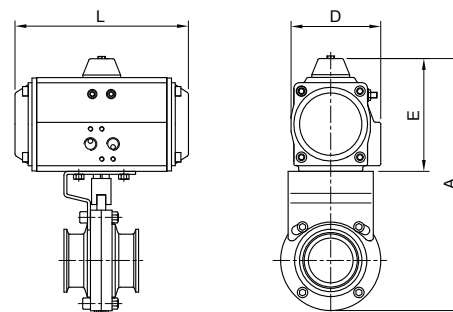

Información técnica
Technical information

Ref.5941E



Válvula mariposa extremos roscados

Características de válvula ver art. 2941E.

Butterfly valve threaded ends

Valve characteristics see art. 2941E.

GNP					
MED.	MOD. ACT	A	E	L	D
1"	GNP-14	194	90	122	65
1 1/4"	GNP-14	202	90	122	65
1 1/2"	GNP-14	202	90	122	65
2"	GNP-14	228	90	122	65
2 1/2"	GNP-24	260	102	147	72
3"	GNP-44	275	102	147	72
4"	GNP-44	314	118	168	83

GNP					
MED.	MOD. ACT	A	E	L	D
1"	GNP-24/S4	206	102	147	72
1 1/4"	GNP-24/S4	214	102	147	72
1 1/2"	GNP-24/S4	214	102	147	72
2"	GNP-44/S4	256	118	168	83
2 1/2"	GNP-60/S5	288	130	184	95
3"	GNP-60/S5	303	130	184	95
4"	GNP-94/S5	335	139	204	103

CÓDIGO CODE	MEDIDA SIZE	TIPO ACT. ACT. TYPE	PESO WEIGHT	P.V.P. € PRICE €
----------------	----------------	------------------------	----------------	---------------------

GNP Doble efecto / GNP Double acting				
5941E 06 122	1"	GNP-14	2.4	228,80
5941E 07 122	1 1/4"	GNP-14	2.85	233,89
5941E 08 122	1 1/2"	GNP-14	2.8	244,08
5941E 09 122	2"	GNP-14	3.5	262,79
5941E 10 125	2 1/2"	GNP-24	4.58	308,17
5941E 11 125	3"	GNP-44	5.45	360,87
5941E 12 128	4"	GNP-44	7.7	461,82
GNP Simple efecto / GNP Spring return				
5941E 06 126	1"	GNP-24/S4	3.44	253,61
5941E 07 126	1 1/4"	GNP-24/S4	2.9	258,71
5941E 08 126	1 1/2"	GNP-24/S4	3.25	268,88
5941E 09 134	2"	GNP-44/S4	4.5	348,98
5941E 10 140	2 1/2"	GNP-60/S5	6.15	376,58
5941E 11 140	3"	GNP-60/S5	6.8	429,28
5941E 12 144	4"	GNP-94/S5	8.7	550,97

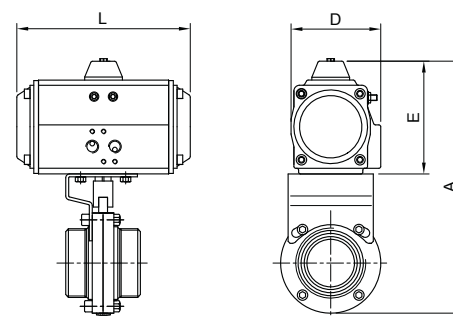

02 LÍNEA SANITARIA
SANITARY LINE



Información técnica
Technical information

Ref.5942E

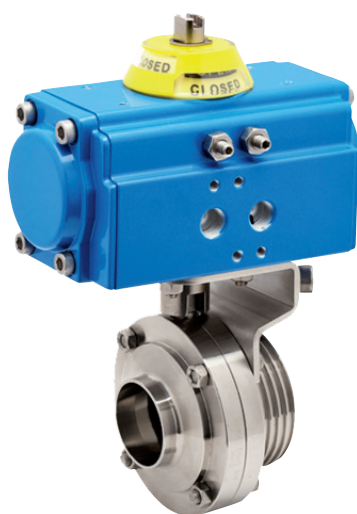

Válvula mariposa extremos roscados/soldar

Características de válvula ver art. 2942E.

Butterfly valve end threaded/welded

Valve characteristics see art. 2942E.

GNP					
MED.	MOD. ACT	A	E	L	D
1"	GNP-14	194	90	122	65
1 1/4"	GNP-14	202	90	122	65
1 1/2"	GNP-14	202	90	122	65
2"	GNP-14	228	90	122	65
2 1/2"	GNP-24	260	102	147	72
3"	GNP-44	275	102	147	72
4"	GNP-44	314	118	168	83

GNP					
MED.	MOD. ACT	A	E	L	D
1"	GNP-24/S4	206	102	147	72
1 1/4"	GNP-24/S4	214	102	147	72
1 1/2"	GNP-24/S4	214	102	147	72
2"	GNP-44/S4	256	118	168	83
2 1/2"	GNP-60/S5	288	130	184	95
3"	GNP-60/S5	303	130	184	95
4"	GNP-94/S5	335	139	204	103

GNP Doble efecto / GNP Double acting				
5942E 06 122	1"	GNP-14	2.08	226,22
5942E 07 122	1 1/4"	GNP-14	2.05	234,14
5942E 08 122	1 1/2"	GNP-14	2.28	241,64
5942E 09 122	2"	GNP-14	2.88	257,94
5942E 10 125	2 1/2"	GNP-24	4.08	301,29
5942E 11 125	3"	GNP-44	4.53	355,21
5942E 12 128	4"	GNP-44	6.28	418,07
GNP Simple efecto / GNP Spring return				
5942E 06 126	1"	GNP-24/S4	2.73	251,02
5942E 07 126	1 1/4"	GNP-24/S4	2.7	258,95
5942E 08 126	1 1/2"	GNP-24/S4	2.93	266,46
5942E 09 134	2"	GNP-44/S4	4.13	344,13
5942E 10 140	2 1/2"	GNP-60/S5	0.01	369,69
5942E 11 140	3"	GNP-60/S5	6.05	423,61
5942E 12 144	4"	GNP-94/S5	7.85	507,25

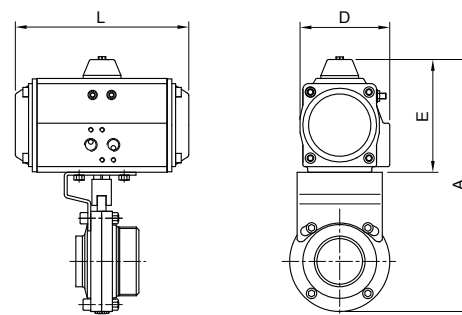

Información técnica
Technical information

Ref.5943E

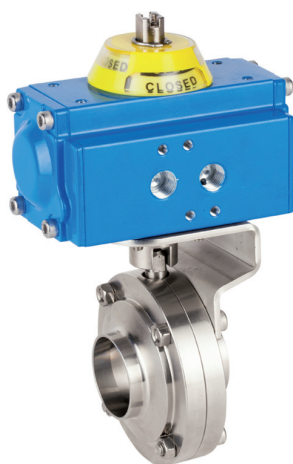

Válvula mariposa extremos soldar/soldar

Características de válvula ver art. 2943E.

Butterfly valve end welded/welded

Valve characteristics see art. 2943E.

GNP					
MED.	MOD. ACT	A	E	L	D
1"	GNP-14	194	90	122	65
1 1/4"	GNP-14	202	90	122	65
1 1/2"	GNP-14	202	90	122	65
2"	GNP-14	228	90	122	65
2 1/2"	GNP-24	260	102	147	72
3"	GNP-44	275	102	147	72
4"	GNP-44	314	118	168	83

GNP					
MED.	MOD. ACT	A	E	L	D
1"	GNP-24/S4	206	102	147	72
1 1/4"	GNP-24/S4	214	102	147	72
1 1/2"	GNP-24/S4	214	102	147	72
2"	GNP-44/S4	256	118	168	83
2 1/2"	GNP-60/S5	288	130	184	95
3"	GNP-60/S5	303	130	184	95
4"	GNP-94/S5	335	139	204	103

CÓDIGO CODE	MEDIDA SIZE	TIPO ACT. ACT. TYPE	PESO WEIGHT	P.V.P. € PRICE €
----------------	----------------	------------------------	----------------	---------------------

GNP Doble efecto / GNP Double acting				
5943E 06 122	1"	GNP-14	1.89	222,32
5943E 07 122	1 1/4"	GNP-14	2.08	232,24
5943E 08 122	1 1/2"	GNP-14	2.3	237,44
5943E 09 122	2"	GNP-14	3	247,35
5943E 10 125	2 1/2"	GNP-24	3.48	285,51
5943E 11 125	3"	GNP-44	4.9	338,90
5943E 12 128	4"	GNP-44	5.08	381,98
GNP Simple efecto / GNP Spring return				
5943E 06 126	1"	GNP-24/S4	2.54	247,13
5943E 07 126	1 1/4"	GNP-24/S4	2.73	257,07
5943E 08 126	1 1/2"	GNP-24/S4	2.74	262,25
5943E 09 134	2"	GNP-44/S4	3.75	333,55
5943E 10 140	2 1/2"	GNP-60/S5	5.278	353,93
5943E 11 140	3"	GNP-60/S5	5.85	407,29
5943E 12 144	4"	GNP-94/S5	7	471,15

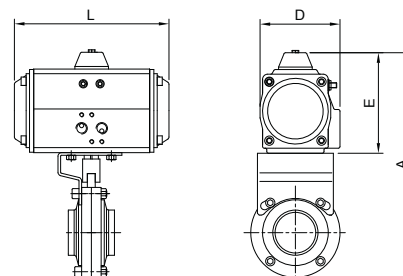

Información técnica
Technical information

Ref.5613



Válvula esfera 3 piezas (Clamp)

Características de válvula ver art. 2933.
Especificar tensión de alimentación necesaria.

3 pieces Clamp ended ball valve

Valve characteristics see art. 2933.
The required tension supply to be specified.

MED.	A	E	L1	D
1/2"	226	171	177	110
3/4"	232	171	177	110
1"	255	171	177	110
1 1/2"	266	171	177	110
2"	306	196	177	110
2 1/2"	335	196	177	110
3"	349	196	177	127
4"	453	254	235	214

5613 04 51	1/2"	GE-0	2.542	409,87
5613 05 51	3/4"	GE-0	2.7	424,33
5613 06 51	1"	GE-0	3	622,13
5613 08 47	1 1/2"	GE-05	4.5	725,24
5613 09 52	2"	GE-1	7.5	1262,46
5613 10 52	2 1/2"	GE-1	12.2	1540,73
5613 11 48	3"	GE-15	17.2	2057,44
5613 12 53	4"	GE-2	25.3	2819,99

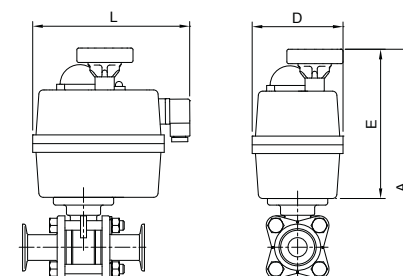

Información técnica
Technical information

Ref.5632



Válvula de esfera extremos roscados/soldar

Características de válvula ver art. 2932.
Especificar tensión de alimentación necesaria.

Ball valve threaded/welded end

Valve characteristics see art. 2932.
The required tension supply to be specified.

MED.	A	E	L1	D
1"	291	171	177	110
1 1/2"	307	171	177	110
2"	358	196	177	110
2 1/2"	388	196	177	110
3"	411	196	177	127

5632 06 51	1"	GE-0	2.13	613,53
5632 08 47	1 1/2"	GE-05	4.35	664,43
5632 09 52	2"	GE-1	6	708,91
5632 10 52	2 1/2"	GE-1	5.33	828,22
5632 11 48	3"	GE-15	12.15	1096,51

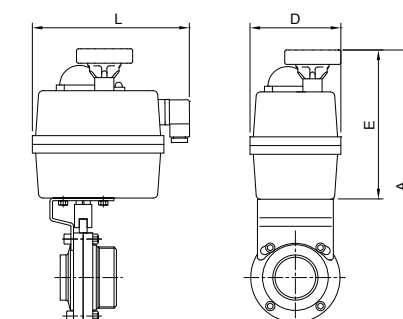

Información técnica
Technical information

Ref.5650



Válvula mariposa extremos Clamp
Características de válvula ver art. 2940.
Especificar tensión de alimentación necesaria.

Butterfly valve Clamp ends
Valve characteristics see art. 2940.
The required tension supply to be specified.

MED.	A	E	L	D
1"	253	149	177	110
1 1/2"	261	149	177	110
2"	283	149	177	110
2 1/2"	296	149	177	110
3"	332	171	177	110
4"	361	171	177	110

CÓDIGO CODE	MEDIDA SIZE	TIPO ACT. ACT. TYPE	PESO WEIGHT	P.V.P. € PRICE €
----------------	----------------	------------------------	----------------	---------------------

5650 06 51	1"	GE-0	3	528,90
5650 08 51	1 1/2"	GE-0	3	540,22
5650 09 51	2"	GE-0	3.6	578,41
5650 10 51	2 1/2"	GE-0	3.75	640,37
5650 11 47	3"	GE-05	4.5	692,91
5650 12 47	4"	GE-05	5.4	891,48

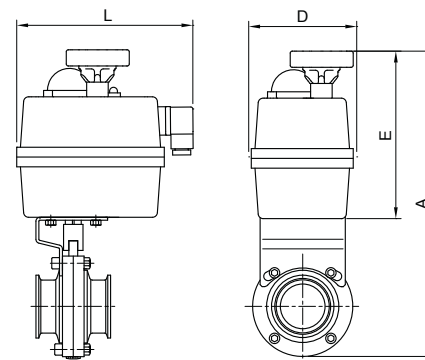

Información técnica
Technical information

Ref.5651E



Válvula mariposa extremos roscados
Características de válvula ver art. 2941E.
Especificar tensión de alimentación necesaria.

Butterfly valve threaded ends
Valve characteristics see art. 2941E.
The required tension supply to be specified.

MED.	A	E	L	D
1"	253	149	177	110
1 1/4"	261	149	177	110
1 1/2"	261	149	177	110
2"	287	149	177	110
2 1/2"	307	149	177	110
3"	344	171	177	110
4"	367	171	177	110

5651E 06 51	1"	GE-0	2.85	488,85
5651E 07 51	1 1/4"	GE-0	3	494,53
5651E 08 51	1 1/2"	GE-0	3.4	505,85
5651E 09 51	2"	GE-0	4	526,64
5651E 10 51	2 1/2"	GE-0	6	557,27
5651E 11 47	3"	GE-05	0.01	615,84
5651E 12 47	4"	GE-05	1	815,71

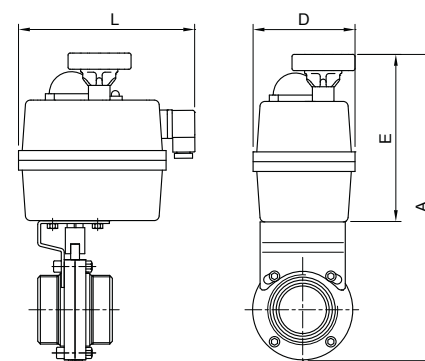

Información técnica
Technical information

Ref.5652E



Válvula mariposa extremos roscado/soldar
Características de válvula ver art. 2942E.
Especificar tensión de alimentación necesaria.

Butterfly valve threaded end/welded
Valve characteristics see art. 2942E.
The required tension supply to be specified.

MED.	A	E	L	D
1"	253	149	177	110
1 1/4"	261	149	177	110
1 1/2"	261	149	177	110
2"	287	149	177	110
2 1/2"	307	149	177	110
3"	344	171	177	110
4"	367	171	177	110

5652E 06 51	1"	GE-0	2.78	485,98
5652E 07 51	1 1/4"	GE-0	2.75	494,79
5652E 08 51	1 1/2"	GE-0	2.98	503,12
5652E 09 51	2"	GE-0	3.58	521,24
5652E 10 51	2 1/2"	GE-0	4.2	549,62
5652E 11 47	3"	GE-05	4.95	609,54
5652E 12 47	4"	GE-05	6.05	767,11

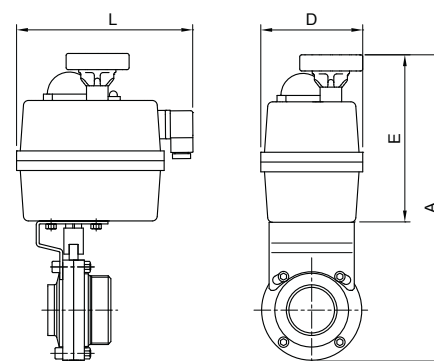

Información técnica
Technical information

Ref.5653E



Válvula mariposa extremos soldar/soldar

Características de válvula ver art. 2943E.
Especificar tensión de alimentación necesaria.

Butterfly valve end welded/welded

Valve characteristics see art. 2943E.
The required tension supply to be specified.

MED.	A	E	L	D
1"	253	149	177	110
1 1/4"	261	149	177	110
1 1/2"	261	149	177	110
2"	287	149	177	110
2 1/2"	307	149	177	110
3"	344	171	177	110
4"	367	171	177	110

CÓDIGO CODE	MEDIDA SIZE	TIPO ACT. ACT. TYPE	PESO WEIGHT	P.V.P. € PRICE €
5653E 06 51	1"	GE-0	3.6	481,66
5653E 07 51	1 1/4"	GE-0	4	492,70
5653E 08 51	1 1/2"	GE-0	2.79	498,47
5653E 09 51	2"	GE-0	4.35	509,48
5653E 10 51	2 1/2"	GE-0	3.6	532,09
5653E 11 47	3"	GE-05	4.2	591,40
5653E 12 47	4"	GE-05	0.01	727,02

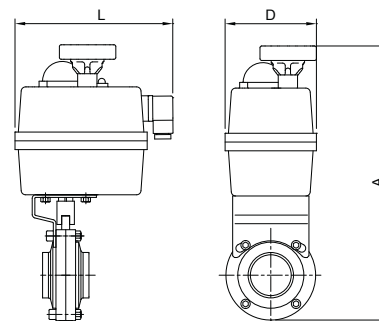

Información técnica
Technical information

Ref.2944 - 2949



Actuador neumático simple efecto para válvulas mariposa línea sanitaria

Extremos clamp/rosca DIN 11851/soldar. Cuerpo de actuador: acero inoxidable 304. Accionamiento neumático a 5 bar.

Pneumatic actuator single acting for butterfly sanitary valves

Ends clamp/threaded DIN 11851/welded. Actuator body: stainless steel 304. Pneumatic operated at 5 bar.

Actuador neumático doble efecto para válvulas mariposa línea sanitaria

Extremos clamp/rosca DIN 11851/soldar. Cuerpo de actuador: acero inoxidable 304. Accionamiento neumático a 5 bar.

Pneumatic actuator double acting for butterfly sanitary valves

Ends clamp/threaded DIN 11851/welded. Actuator body: stainless steel 304. Pneumatic operated at 5 bar.

MED.	DN	A	D
1"-2"	25-50	193	85

MED.	1"-2"	2 1/2"-3"	4"
DN	25-50	65-80	100

CÓDIGO CODE	MEDIDA SIZE	PESO WEIGHT	P.V.P. € PRICE €
2944	1"-4"	2.745	446,21

2949	1"-4"	2.554	446,21
------	-------	-------	---------------

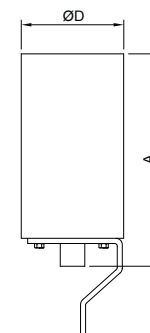

Información técnica
Technical information

Ref.5944 - 5949



Microrruptor final de carrera con actuador simple efecto

Cabezal de control con 2 detectores.
Cabezal de control con 2 detectores y 1 electroválvula incorporada.

Microswitch end stop with spring return actuator

Control top with 2 switch.
Control top with 2 switch and 1 solenoid valve inside.

Microrruptor final de carrera con actuador doble efecto

Cabezal de control con 2 detectores.
Cabezal de control con 2 detectores y 2 electroválvulas incorporadas.

Microswitch end stop with double acting actuator

Control top with 2 switch.
Control top with 2 switch and 2 solenoid valves inside.

CÓDIGO CODE	MEDIDA SIZE	TIPO ACT. ACT. TYPE	PESO WEIGHT	P.V.P. € PRICE €
----------------	----------------	------------------------	----------------	---------------------

5944 01	-	-	3.55	776,33
5944 02	-	-	3.55	981,19

5949 01	-	-	3.05	776,33
5949 02	-	-	3.045	1175,93



Información técnica
Technical information

03.

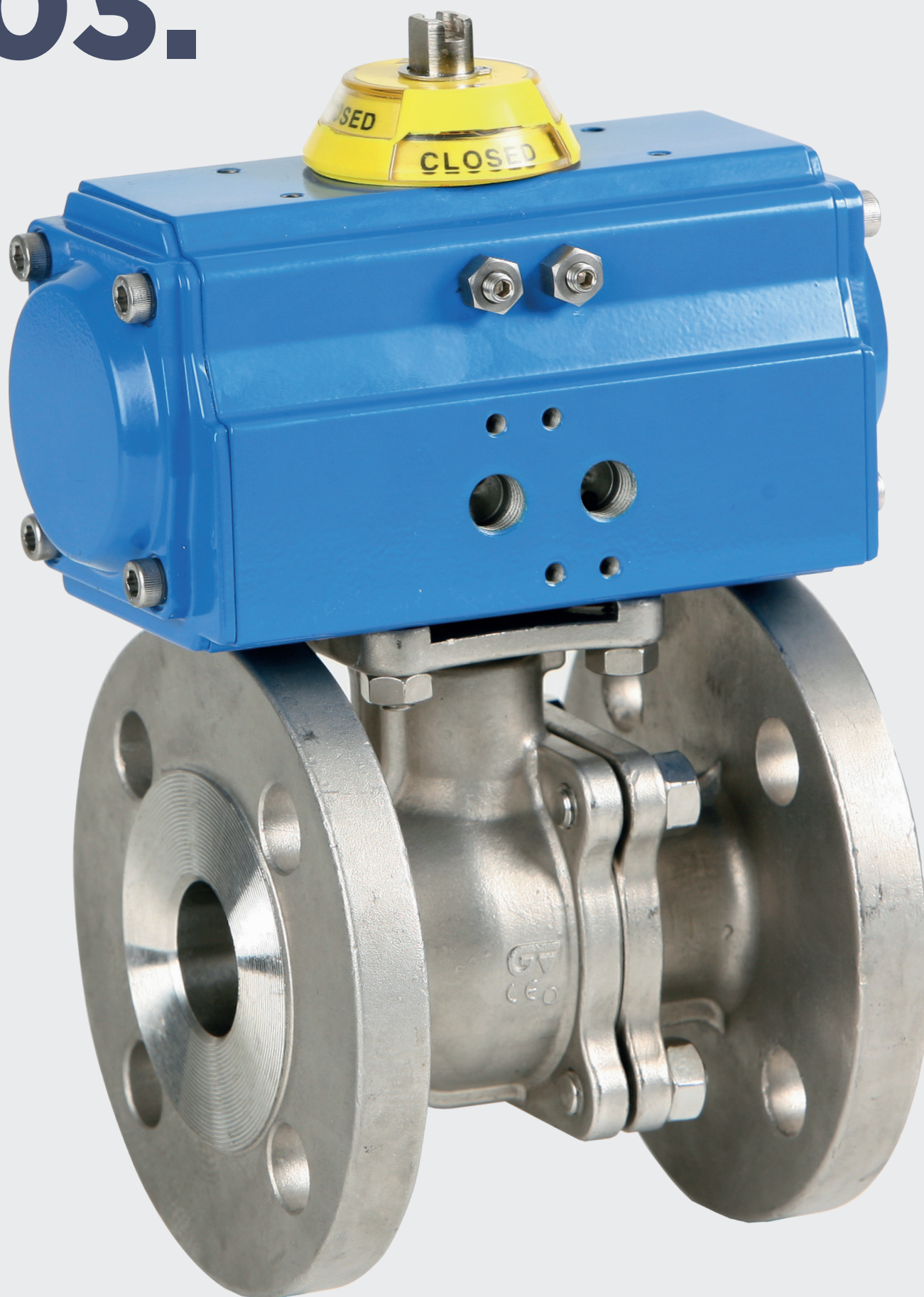

AUTOMATIZACIÓN Y CONTROL

Automation & Control

Válvulas equipadas con actuador neumático rotativo giro 90°. Simple efecto y doble efecto para accionamiento automático y a distancia.

Valves equipped with 90° rotation pneumatic actuator, spring return and double acting for automatic and remote operation.

Válvulas neumáticas / Pneumatic valves	p. 93
Actuador neumático / Pneumatic actuators	p. 94
Electroválvulas / Solenoid valves	p. 114
Posicionadores / Positioners	p. 116
Reductores / Gear operators	p. 117
Microrruptores final de carrera / Limit switch box	p. 118
Extensor para válvula automatizada - actuador pнемático / Extension for automated valve - pneumatic actuator	p. 121
Actuador eléctrico monofásico / Single phase electric actuators	p. 124-135
Actuador eléctrico trifásico / Three-phase electric actuators	p. 127-136
Extensor para válvula automatizada - actuador eléctrico / Extension for automated valve - electric actuator	p. 137

Automatización y control

Automation and control

Válvulas equipadas con actuador neumático rotativo giro 90°. Simple efecto y doble efecto para accionamiento automático y a distancia.

Valves equipped with 90° rotation pneumatic actuator, spring return and double acting for automatic and remote operation

Características de los actuadores

Actuadores neumáticos con piñón y cremallera cuarto de vuelta (90°).

Toda la serie de actuadores han sido proyectados según las normas NAMUR, VDI/VDE 3845 e ISO 5211.

Pueden ser accionados con aire comprimido o gases no corrosivos a presión de 8 y 10 bar según modelo.

Tipos de actuadores

- D.A.**
- Doble efecto
 - Presión aire para abrir y cerrar
- S.R.**
- Simple efecto N.A.
 - Presión aire para cerrar válvula
 - Normal abierto
 - Retorno a posición abierta por muelles
- S.R.**
- Simple efecto N.C.
 - Presión aire para abrir válvula
 - Normal cerrado
 - Retorno a posición cerrada por muelles

Modelos de actuadores

GN / GN-S. Aluminio extrusionado ASTM 6005 con anodizado exterior e interior. Presión de 4 a 10 bar. Temperatura: -20°C +80°C.

GNP / GNP-S. Cuerpo y tapas en aleación de aluminio anodizado y posterior recubrimiento externo con pintura de poliéster en polvo para resistencia a la corrosión.

Presión de trabajo de 2,5 a 8 bar. Temperatura de trabajo -20°C + 80°C.

Homologación ATEX. Según Directiva 94/9/CE para atmósferas explosivas: Categoría II2 GDT5 (Zona 1,2/ 21,22).

Notas importantes

Los equipos actuador/válvula que presentamos en esta tarifa, corresponden a las siguientes condiciones de trabajo:

- Líquidos limpios y no agresivos.
- Presión diferencial máx.: 16 Kgs./cm².
- Presión de alimentación mínima: 6 Bar.

Para otras condiciones de trabajo, rogamos nos consulten.

Dispositivos de control - Opcionales

Mando manual de emergencia.

Electroválvulas 3 y 5 vías "Namur" IP-65.

Finales de carrera (Electromecánicos- Inductivos).

Posicionadores neumáticos, señal 3-15 psi.

Posicionadores electroneumáticos, señal 4-20 mA.

Characteristics of the actuators

Pneumatic actuators with rack and pinion quarter turn (90°).

The whole actuator series has been projected according to the standard NAMUR, VDI/VDE 3845 and ISO 5211.

They can be operated with compressed air or any other noncorrosive gases under pressure of 8 and 10 bars according to the model.

Type of actuators

- D.A.**
- Double acting
 - Air pressure for opening and closing
- S.R.**
- Spring Return NA
 - Air pressure for closing valve
 - Normal open
 - Return to open position with springs
- S.R.**
- Spring Return NC
 - Air pressure for opening valve
 - Normal closed
 - Return to closed position with springs

Actuator models

GN / GN-S. Extruded aluminium ASTM 6005 with all internal and external surfaces anodized for corrosion resistance.

Except for Mod. GN10 and GN 10/S. Technopolymer construction with aluminium end. Pressure from 4 to 10 bar. Temperature from -20°C to +80°C.

GNP / GNP-S. Aluminium alloy body and caps with all anodized surface and external surface with powder polyester painted for corrosion resistance. Working pressure from 2.5 to 8 bar. Working temperature -20°C + 80°C.

ATEX certification according. To 94/9/CE for explosives atmospheres: Class II2 GDT5 (Zones 1,2/ 21, 22).

Important

The actuator / valve equipment that we present in this PRICE LIST are suitable for the following working conditions:

- Clean, non-aggressive liquids.
- Differential pressure max. 16 kg/cm².
- Minimum feed pressure: 6 bar.

For other working conditions, please contact us.

Safety devices - Optional

Manual emergency control.

3 and 5 way "Namur" solenoid valve IP-65.

Microswitches (Electromechanical- Inductive).

Pneumatic positioners, signal 3-15 psi.

Electropneumatic positioners, signal 4-20 mA.

Ref. 5060 - 5060N



Válvula asiento inclinado con actuador neumático de simple efecto También disponible con rosca NPT (5060N). Extremos rosca gas ISO 228-1, PN-16. Const.: acero inox. AISI 316 microfundición. Junta actuador: NBR. Presión mando. Actuador: 3-10 kg/cm². Rango temp. trabajo: -10°C +180°C.

Angle seat valve with spring return actuator Also available in NPT thread (5060N). Gas threaded ends ISO 228-1, PN-16. Constr.: stainless steel AISI 316 investment casting. Actuator seal: NBR. Working temp. range: -10°C +180°C. Pressure control actuator: 3-10 kg/cm².

MED.	A	B	L	D
1/2"	133	126	68	60
3/4"	137	131	75	60
1"	149	140	90	60
1 1/4"	188	175	116	75
1 1/2"	190	178	116	75
2"	203	184	138	75

CÓDIGO CODE	MEDIDA SIZE	PESO WEIGHT	P.V.P. € PRICE €
5060 04	1/2"	0.974	168,68
5060 05	3/4"	1.077	175,87
5060 06	1"	1.318	182,63
5060 07	1 1/4"	2.351	279,48
5060 08	1 1/2"	2.569	296,50
5060 09	2"	3.365	361,19

Precios rosca NPT a consultar / NPT thread prices on request

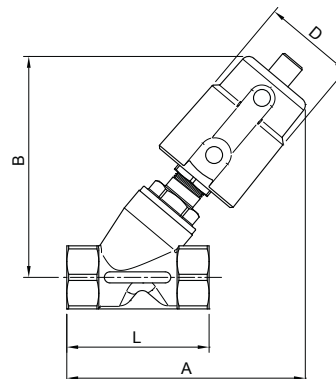

Información técnica
Technical information

Ref. 5062 - 5062N



Válvula neumática de corredera

Construcción en acero inoxidable AISI 304. Extremos rosca gas ISO 228-1. Material de cierre: EPDM. Conexión neumática Namur. Presión máxima de trabajo 16 PN. Accionamiento simple efecto (retorno a resorte).

Pneumatic shuttle valve

Stainless steel material AISI 304. Gas thread ends ISO 228-1. Seat EPDM material. Namur pneumatic connection. Maximum working pressure 16 PN. Control by single action (spring return).

MED.	A	B	D	L
3/8"	54	31	46	98
1/2"	59	33	52	112
3/4"	70	38	64	135
1"	76	41	69	143
1 1/4"	92	49	86	165
1 1/2"	102	54	96	180
2"	114	60	108	207

5062 03	3/8"	0.8	126,12
5062 04	1/2"	1.045	141,84
5062 05	3/4"	1.51	170,14
5062 06	1"	1.906	195,62
5062 07	1 1/4"	3.023	249,86
5062 08	1 1/2"	3.9	301,73
5062 09	2"	5.509	402,17

Precios rosca NPT a consultar / NPT thread prices on request

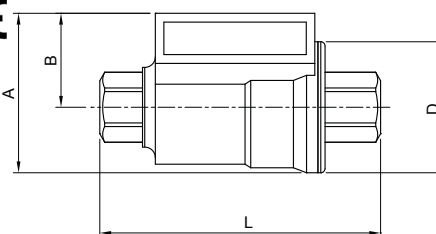

Información técnica
Technical information

Ref. 5065



Válvula neumática 2 vías modulante

Construcción en acero al carbono WCB. Extremos bridados DIN PN 16. Asiento PPL. Temperatura de trabajo -20°C/+230°C.

2 ways modulate pneumatic valve

Body: carbon steel WCB. DIN PN 16 flange ends. Seat material: PPL. Working temperature -20°C/+230°C.

MED.	A	B	H	L
1/2"	95	228	475	150
3/4"	105	228	480	150
1"	115	228	480	160
1 1/4"	140	228	480	180
1 1/2"	150	272	552	200
2"	165	272	552	230
2 1/2"	185	272	592	290
3"	200	272	592	310
4"	220	272	592	350

5065 04	1/2"	17.793	1069,08
5065 05	3/4"	19.681	1139,01
5065 06	1"	19.068	1177,68
5065 07	1 1/4"	20.521	1271,71
5065 08	1 1/2"	30.162	1405,65
5065 09	2"	33.294	1565,92
5065 10	2 1/2"	48.12	2196,83
5065 11	3"	50.069	3747,57
5065 12	4"	58.15	4860,89

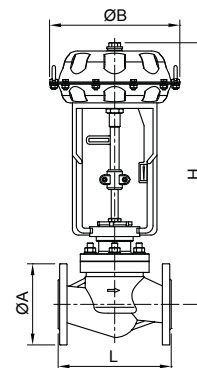

Información técnica
Technical information

Ref. 5065A



Válvula neumática 2 vías modulante

Construcción en acero al carbono WCB.
Extremos bridados ANSI S-150.
Asientos PPL.
Temperatura de trabajo: -10°C/+230°C.

2 ways modulate pneumatic valve

Body: carbon steel WCB.
ANSI S-150 Flange ends.
Seat material: PPL.
Working temperature: -10°C/+230°C

MED.	A	B	H	L
3/4"	98,6	228	535	184
1"	108	228	535	184
1 1/4"	117	228	480	200
1 1/2"	127	272	552	222
2"	152,5	272	552	254
2 1/2"	177,8	272	592	276
3"	190,5	272	592	298
4"	228,6	272	592	352

CÓDIGO CODE	MEDIDA SIZE	PESO WEIGHT	P.V.P. € PRICE €
5065A 05	3/4"	18.416	1443,45
5065A 06	1"	19.25	1491,91
5065A 07	1 1/4"	19.367	1598,47
5065A 08	1 1/2"	29.457	1763,14
5065A 09	2"	32.481	1908,48
5065A 10	2 1/2"	46.663	2736,77
5065A 11	3"	50.375	4092,07
5065A 12	4"	66.31	5725,42

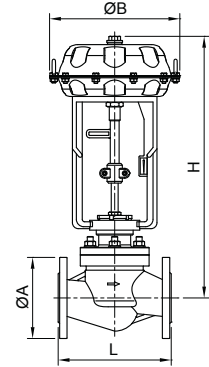

Información técnica
Technical information

Ref. 5015



Válvula esfera 2 piezas / Actuador GNP

Características de la válvula ver artículo 2015

2 pieces ball valve / GNP Actuator
Valve characteristics see art. 2015

GNP					
MED.	MOD. ACT	A	E	L	D
1/4"	GNP-14	132	80	122	65
3/8"	GNP-14	132	80	122	65
1/2"	GNP-14	165	80	122	65
3/4"	GNP-14	174	80	122	65
1"	GNP-14	180	80	122	65
1 1/4"	GNP-44	202,5	117,5	168	83
1 1/2"	GNP-44	214,5	177,5	168	83
2"	GNP-44	228,5	177,5	168	83

GNP					
MED.	MOD. ACT	A	E	L	D
1/4"	GNP-24/S4	154	102	147	71,5
3/8"	GNP-24/S4	154	102	147	71,5
1/2"	GNP-24/S4	157	102	147	71,5
3/4"	GNP-44/S4	181,5	117,5	168	83
1"	GNP-44/S5	186,5	117,5	168	83
1 1/4"	GNP-60/S5	214,5	129,5	184	92
1 1/2"	GNP-94/S5	235,5	138,5	204	103
2"	GNP-135/S5	258	147	262	108,5

CÓDIGO CODE	MEDIDA SIZE	TIPO ACT. ACT. TYPE	PESO WEIGHT	P.V.P. € PRICE €
GNP Doble efecto / GNP Double acting				
5015 02 120	1/4"	GNP-14	1.3	123,00
5015 03 120	3/8"	GNP-14	1.43	123,00
5015 04 122	1/2"	GNP-14	1.31	123,70
5015 05 122	3/4"	GNP-14	1.63	130,74
5015 06 122	1"	GNP-14	2.02	143,57
5015 07 128	1 1/4"	GNP-44	3.68	188,21
5015 08 128	1 1/2"	GNP-44	4.01	205,44
5015 09 128	2"	GNP-44	4.93	257,02
GNP Simple efecto / GNP Spring return				
5015 02 124	1/4"	GNP-24/S4	1.795	141,12
5015 03 124	3/8"	GNP-24/S4	2.61	141,12
5015 04 126	1/2"	GNP-24/S4	2.1	169,23
5015 05 132	3/4"	GNP-44/S4	3.8	184,60
5015 06 136	1"	GNP-44/S5	3.21	204,18
5015 07 140	1 1/4"	GNP-60/S5	4.25	254,72
5015 08 144	1 1/2"	GNP-94/S5	5.51	299,84
5015 09 148	2"	GNP-135/S5	8.33	366,02

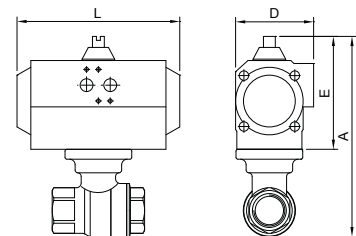

Información técnica
Technical information

Ref. 5025 - 5026 - 5027

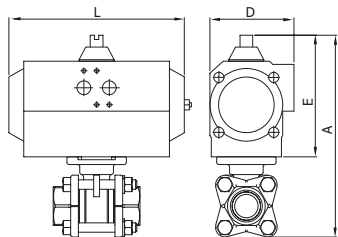

Válvula esfera 3 piezas / Actuador Gen-Air

Características de la válvula ver artículos 2025/2026/2027

3 piezas ball valve / Gen-Air actuator

Valve characteristics see articles 2025/2026/2027

GN					
MED.	MOD. ACT	A	E	L	D
1/4"	GN-05	157	101	119	67
3/8"	GN-05	157	101	119	67
1/2"	GN-05	190	101	119	67
3/4"	GN-05	199	101	119	67
1"	GN-05	204	101	119	67
1 1/4"	GN-15	201	111	165	81
1 1/2"	GN-15	211	111	165	81
2"	GN-17	224	111	197	81
2 1/2"	GN-20	300	128	177	96
3"	GN-25	321	128	239	96
4"	GN-35	391	184	246	131

GN					
MED.	MOD. ACT	A	E	L	D
1/4"	GN-05/S2	157	101	119	67
3/8"	GN-05/S2	157	101	119	67
1/2"	GN-15/S3	170	111	165	81
3/4"	GN-15/S4	179	111	165	81
1"	GN-17/S4	184	111	197	81
1 1/4"	GN-20/S4	218	128	177	96
1 1/2"	GN-25/S4	228	128	239	96
2"	GN-30/S4	260	147	230	114
2 1/2"	GN-35/S3	356	184	246	131
3"	GN-40/S4	377	184	290	131
4"	GN-45/S4	458	198	351	145



Información técnica
Technical information

CÓDIGO CODE	MEDIDA SIZE	TIPO ACT. ACT. TYPE	PESO WEIGHT	P.V.P. € PRICE €
----------------	----------------	------------------------	----------------	---------------------

5025 / 5026 / 5027 Gen-Air Doble efecto / Gen-Air Double acting

5025 04 44	1/2"	GN-05	1.613	136,83
5025 05 44	3/4"	GN-05	2.06	144,10
5025 06 44	1"	GN-05	2.28	152,35
5025 07 48	1 1/4"	GN-15	3.65	206,89
5025 08 48	1 1/2"	GN-15	4.18	230,41
5025 09 52	2"	GN-17	7.08	276,31
5025 10 64	2 1/2"	GN-20	11.37	513,94
5025 11 65	3"	GN-25	16.4	680,32
5025 12 67	4"	GN-35	28.93	1124,51

5025 / 5026 / 5027 Gen-Air Simple efecto / Gen-Air Spring return

5025 02 45	1/4"	GN-05/S2	1.335	146,28
5025 03 45	3/8"	GN-05/S2	1.335	146,28
5025 04 73	1/2"	GN-15/S3	2.66	179,98
5025 05 74	3/4"	GN-15/S4	2.82	200,74
5025 06 49	1"	GN-17/S4	3.61	202,37
5025 07 76	1 1/4"	GN-20/S4	5	287,52
5025 08 77	1 1/2"	GN-25/S4	6.35	341,93
5025 09 78	2"	GN-30/S4	9.05	404,32
5025 10 79	2 1/2"	GN-35/S3	15.83	696,49
5025 11 80	3"	GN-40/S4	21.2	900,25
5025 12 81	4"	GN-45/S4	36.37	1330,78

*Precios rosca NPT ref 5025N a consultar / *NPT thread ref. 5025N prices on request

Ref. 5025 - 5026 - 5027

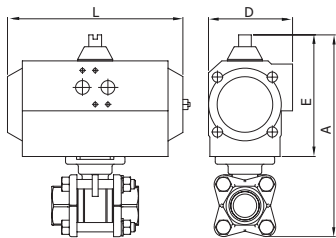

Válvula esfera 3 piezas / Actuador GNP

Características de la válvula ver artículos 2025/2026/2027

3 piezas ball valve / GNP Actuator

Valve characteristics see articles 2025/2026/2027

GNP					
MED.	MOD. ACT	A	E	L	D
1/4"	GNP-14	136	80	122	65
3/8"	GNP-14	136	80	122	65
1/2"	GNP-14	169	80	122	65
3/4"	GNP-14	178	80	122	65
1"	GNP-14	183	80	122	65
1 1/4"	GNP-44	207,5	117,5	168	83
1 1/2"	GNP-44	217,5	117,5	168	83
2"	GNP-44	230,5	117,5	168	83
2 1/2"	GNP-94	310,5	138,5	204	103
3"	GNP-94	331,5	138,5	204	103
4"	GNP-198	423	163	268	121,5

GNP					
MED.	MOD. ACT	A	E	L	D
1/4"	GNP-24/S4	158	102	147	71,5
3/8"	GNP-24/S4	158	102	147	71,5
1/2"	GNP-24/S4	161	102	147	71,5
3/4"	GNP-44/S4	185,5	117,5	168	83
1"	GNP-44/S5	190,5	117,5	168	83
1 1/4"	GNP-60/S5	219,5	129,5	184	92
1 1/2"	GNP-94/S5	238,5	138,5	204	103
2"	GNP-135/S5	260	147	262	108,5
2 1/2"	GNP-198/S4	335	163	268	121,5
3"	GNP-300/S5	378	185	296	142
4"	GNP-513/S5	461,5	201,5	390	152



Información técnica
Technical information

5025 / 5026 / 5027 GNP Doble efecto / GNP Double acting

5025 02 120	1/4"	GNP-14	1.415	123,03
5025 03 120	3/8"	GNP-14	1.18	123,03
5025 04 122	1/2"	GNP-14	1.76	125,18
5025 05 122	3/4"	GNP-14	1.826	129,58
5025 06 122	1"	GNP-14	2.165	137,03
5025 07 128	1 1/4"	GNP-44	3.92	196,37
5025 08 128	1 1/2"	GNP-44	4.45	217,54
5025 09 128	2"	GNP-44	5.55	253,49
5025 10 142	2 1/2"	GNP-94	11.8	503,30
5025 11 142	3"	GNP-94	15.7	603,27
5025 12 150	4"	GNP-198	27.25	1005,75

5025 / 5026 / 5027 GNP Simple efecto / GNP Spring return

5025 02 124	1/4"	GNP-24/S4	1.9	139,56
5025 03 124	3/8"	GNP-24/S4	1.9	139,56
5025 04 126	1/2"	GNP-24/S4	2.8	175,17
5025 05 132	3/4"	GNP-44/S4	3	187,74
5025 06 136	1"	GNP-44/S5	3.22	204,40
5025 07 140	1 1/4"	GNP-60/S5	4.65	263,64
5025 08 144	1 1/2"	GNP-94/S5	6.06	312,71
5025 09 148	2"	GNP-135/S5	8.98	376,01
5025 10 152	2 1/2"	GNP-198/S4	15.2	622,16
5025 11 160	3"	GNP-300/S5	22.79	850,34
5025 12 164	4"	GNP-513/S5	35.75	1267,74

*Precios rosca NPT ref 5025N a consultar / *NPT thread ref. 5025N prices on request

Ref.5029

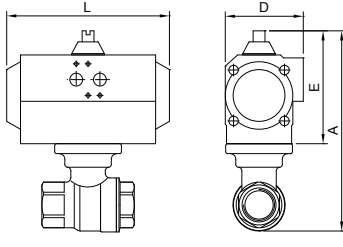

Válvula esfera 2 piezas / Actuador GNP

Características de la válvula ver artículo 3023 hasta 2" y ver art. 3029 de 2 1/2" a 4".

2 pieces ball valve / GNP Actuator

Valve characteristics see art. 3023 until 2" and see art. 3029 from 2 1/2" to 4".

GNP					
MED.	MOD. ACT	A	E	L	D
1/2"	GNP-14	123	80	122	65
3/4"	GNP-14	130	80	122	65
1"	GNP-14	137	80	122	65
1 1/4"	GNP-44	187,5	117,5	168	83
1 1/2"	GNP-44	198,5	117,5	168	83
2"	GNP-44	216,5	117,5	168	83
2 1/2"	GNP-94	296,5	138,5	204	105
3"	GNP-135	331	147	262	108,5
4"	GNP-300	410	185	296	142

GNP					
MED.	MOD. ACT	A	E	L	D
1/2"	GNP-24/S4	145	102	147	71,5
3/4"	GNP-24/S4	152	102	147	71,5
1"	GNP-44/S4	174,5	117,5	168	83
1 1/4"	GNP-44/S4	187,5	117,5	168	83
1 1/2"	GNP-60/S5	200,5	119,5	184	95
2"	GNP-94/S5	228	129	204	103
2 1/2"	GNP-300/S5	349	185	296	142
3"	GNP-513/S5	385,5	201,5	390	152
4"	GNP-1280/S5	480	260	525	206

CÓDIGO CODE	MEDIDA SIZE	TIPO ACT. ACT. TYPE	PESO WEIGHT	P.V.P. € PRICE €
-------------	-------------	---------------------	-------------	------------------

GNP Doble efecto / GNP Double acting

5029 04 120	1/2"	GNP-14	1.74	128,27
5029 05 120	3/4"	GNP-14	1.145	133,30
5029 06 122	1"	GNP-14	1.92	141,62
5029 07 128	1 1/4"	GNP-44	2.98	190,88
5029 08 128	1 1/2"	GNP-44	4.1	199,66
5029 09 128	2"	GNP-44	4.2	236,74
5029 10 142	2 1/2"	GNP-94	6.95	416,72
5029 11 146	3"	GNP-135	10.1	502,33
5029 12 158	4"	GNP-300	15.94	687,19

GNP Simple efecto / GNP Spring return

5029 04 124	1/2"	GNP-24/S4	1.73	141,27
5029 05 124	3/4"	GNP-24/S4	1.84	146,30
5029 06 134	1"	GNP-44/S4	3.6	178,77
5029 07 132	1 1/4"	GNP-44/S4	3.08	214,26
5029 08 140	1 1/2"	GNP-60/S5	4.17	254,20
5029 09 144	2"	GNP-94/S5	5.7	319,16
5029 10 160	2 1/2"	GNP-300/S5	14.05	639,69
5029 11 164	3"	GNP-513/S5	19.5	863,29
5029 12 172	4"	GNP-1280/S5	54.65	1513,05



Información técnica
Technical information

Ref.5070



Válvula de esfera 3 vías "L" / Actuador GNP

Características de la válvula ver artículo 3272E

"L" 3 ways ball valve / GNP Actuator

Valve characteristics see articles 3272E

GNP					
MED.	MOD. ACT	A	E	L	D
1/2"	GNP-14	131	80	122	65
3/4"	GNP-14	140	80	122	65
1"	GNP-24	172	102	147	71,5

GNP					
MED.	MOD. ACT	A	E	L	D
1/2"	GNP-24/S4	153	102	147	71,5
3/4"	GNP-44/S4	177	117,5	168	83
1"	GNP-44/S4	188	117,5	168	83

GNP Doble efecto / GNP Double acting

5070 04 120	1/2"	GNP-14	1.28	131,03
5070 05 122	3/4"	GNP-14	2.52	141,57
5070 06 125	1"	GNP-24	2.36	204,26

GNP Simple efecto / GNP Spring return

5070 04 124	1/2"	GNP-24/S4	1.98	151,57
5070 05 134	3/4"	GNP-44/S4	2.94	187,39
5070 06 134	1"	GNP-44/S4	4.42	209,69

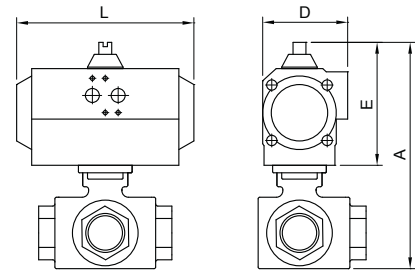

Información técnica
Technical information



Ref.5080

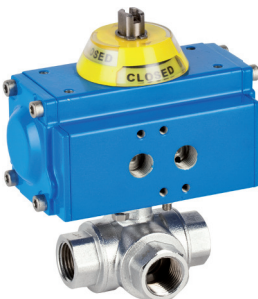

Válvula esfera 3 vías "T" / Actuador GNP

Características de la válvula ver artículo 3282E

"T" 3 ways ball valve

Valve characteristics see article 3282E

GNP					
MED.	MOD. ACT	A	E	L	D
1/2"	GNP-14	131	80	122	65
3/4"	GNP-14	140	80	122	65
1"	GNP-24	172	102	147	71,5

GNP					
MED.	MOD. ACT	A	E	L	D
1/2"	GNP-24/S4	153	102	147	71,5
3/4"	GNP-44/S4	177	117,5	168	83
1"	GNP-44/S4	188	117,5	168	83

GNP Doble efecto / GNP Double acting

5080 04 120	1/2"	GNP-14	1.76	131,03
5080 05 122	3/4"	GNP-14	1.54	141,57
5080 06 125	1"	GNP-24	2.28	204,26

GNP Simple efecto / GNP Spring return

5080 04 124	1/2"	GNP-24/S4	1.98	151,57
5080 05 134	3/4"	GNP-44/S4	2.88	187,39
5080 06 134	1"	GNP-44/S4	3.3	209,69

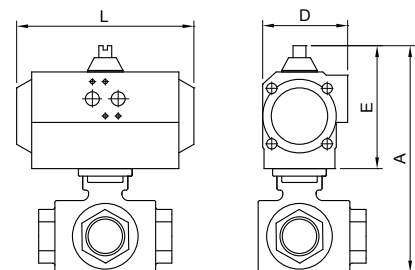

Información técnica
Technical information



Ref.5040

Válvula esfera 3 vías "L"

Características de la válvula ver artículo 2040.

"L" 3 ways ball valve

Valve characteristics see article 2040.

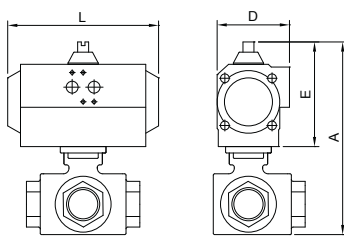

GNP					
MED.	MOD. ACT	A	E	L	D
1/4"	GNP-14	142	80	122	65
3/8"	GNP-14	142	80	122	65
1/2"	GNP-14	142	80	122	65
3/4"	GNP-14	151,5	80	122	65
1"	GNP-44	203,5	117,5	168	83
1 1/4"	GNP-44	218	117,5	168	83
1 1/2"	GNP-44	230,5	117,5	168	83
2"	GNP-60	260	129,5	184	92
2 1/2"	GNP-94	289	139	204	103

GNP					
MED.	MOD. ACT	A	E	L	D
1/4"	GNP-24/S4	164	102	147	71,5
3/8"	GNP-24/S4	164	102	147	71,5
1/2"	GNP-24/S4	164	102	147	71,5
3/4"	GNP-44/S4	189	117,5	168	83
1"	GNP-44/S4	203,5	117,5	168	83
1 1/4"	GNP-60/S5	230	129,5	184	92
1 1/2"	GNP-94/S5	251,5	138,5	204	103
2"	GNP-198/S4	293,5	163	268	122
2 1/2"	GNP-198/S6	313	163	268	122



Información técnica
Technical information

CÓDIGO CODE	MEDIDA SIZE	TIPO ACT. ACT. TYPE	PESO WEIGHT	P.V.P. € PRICE €
----------------	----------------	------------------------	----------------	---------------------

GNP Doble efecto / GNP Double acting

5040 02 122	1/4"	GNP-14	1.66	176,60
5040 03 122	3/8"	GNP-14	1.65	176,60
5040 04 122	1/2"	GNP-14	1.7	178,13
5040 05 122	3/4"	GNP-14	1.8	191,00
5040 06 128	1"	GNP-44	4.06	241,79
5040 07 128	1 1/4"	GNP-44	5.03	306,39
5040 08 128	1 1/2"	GNP-44	5.98	348,13
5040 09 138	2"	GNP-60	9.75	491,20
5040 10 142	2 1/2"	GNP-94	12.5	829,13

GNP Simple efecto / GNP Spring return

5040 02 126	1/4"	GNP-24/S4	0.001	192,22
5040 03 126	3/8"	GNP-24/S4	2.305	192,22
5040 04 126	1/2"	GNP-24/S4	2.355	193,89
5040 05 132	3/4"	GNP-44/S4	4	238,72
5040 06 132	1"	GNP-44/S4	3.94	256,21
5040 07 140	1 1/4"	GNP-60/S5	5.35	358,39
5040 08 144	1 1/2"	GNP-94/S5	7.52	430,54
5040 09 152	2"	GNP-198/S4	12.68	606,65
5040 10 156	2 1/2"	GNP-198/S6	16	978,74

Ref.5041

Válvula esfera 3 vías "T"

Características de la válvula ver artículo 2041.

"T" 3 ways ball valve

Valve characteristics see article 2041.

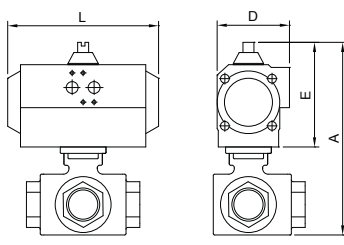

GNP					
MED.	MOD. ACT	A	E	L	D
1/4"	GNP-14	142	80	122	65
3/8"	GNP-14	142	80	122	65
1/2"	GNP-14	142	80	122	65
3/4"	GNP-14	151,5	80	122	65
1"	GNP-44	203,5	117,5	168	83
1 1/4"	GNP-44	218	117,5	168	83
1 1/2"	GNP-44	230,5	117,5	168	83
2"	GNP-60	260	129,5	184	92
2 1/2"	GNP-94	289	139	204	103

GNP					
MED.	MOD. ACT	A	E	L	D
1/4"	GNP-24/S4	164	102	147	71,5
3/8"	GNP-24/S4	164	102	147	71,5
1/2"	GNP-24/S4	164	102	147	71,5
3/4"	GNP-44/S4	189	117,5	168	83
1"	GNP-44/S4	203,5	117,5	168	83
1 1/4"	GNP-60/S5	230	129,5	184	92
1 1/2"	GNP-94/S5	251,5	138,5	204	103
2"	GNP-198/S4	293,5	163	268	122
2 1/2"	GNP-198/S6	313	163	268	122



Información técnica
Technical information

GNP Doble efecto / GNP Double acting

5041 02 122	1/4"	GNP-14	1.66	176,60
5041 03 122	3/8"	GNP-14	1.65	176,60
5041 04 122	1/2"	GNP-14	1.7	178,13
5041 05 122	3/4"	GNP-14	1.8	191,00
5041 06 128	1"	GNP-44	4.38	241,79
5041 07 128	1 1/4"	GNP-44	5.03	306,39
5041 08 128	1 1/2"	GNP-44	5.98	348,13
5041 09 138	2"	GNP-60	8.74	491,42
5041 10 142	2 1/2"	GNP-94	12.3	829,13

GNP Simple efecto / GNP Spring return

5041 02 126	1/4"	GNP-24/S4	2.315	192,22
5041 03 126	3/8"	GNP-24/S4	2.305	192,22
5041 04 126	1/2"	GNP-24/S4	2.355	193,89
5041 05 132	3/4"	GNP-44/S4	3.05	238,72
5041 06 132	1"	GNP-44/S4	3.94	256,21
5041 07 140	1 1/4"	GNP-60/S5	5.35	358,39
5041 08 144	1 1/2"	GNP-94/S5	7.52	430,54
5041 09 152	2"	GNP-198/S4	12.68	606,65
5041 10 156	2 1/2"	GNP-198/S6	15.6	978,74

Ref.5052



Válvula esfera paso total fondo de cubas

Const. acero inox. CF8M (316) y 316l (fondo de cubas). Extremo rosca gas ISO 7-1 (EN 10226-1) y fondo de cubas. Asientos PTFE + 15% FV. Tórica eje vitón. PN 63. Temp. -25°C +180°C. Montaje directo S/ISO 5211. Mando manual por palanca con sistema de bloqueo. Con actuador GNP.

Tank bottom full bore ball valve

Const. stainless steel CF8M (316) and 316l (tank bottom). Ends: gas thread ISO 7-1 (EN 10226-1) and tank bottom. Seats: PTFE + 15% FV. O'ring stem: viton. PN 63. Temp. -25°C +180°C. Direct assembling ISO 5211. Manually operated by handle with locking system. With GNP actuator.

GNP					
MED.	MOD. ACT	A	E	L	D
1/2"	GNP-14	163	90	122	65
3/4"	GNP-14	174	90	122	65
1"	GNP-14	181	90	122	65
1 1/4"	GNP-44	227	118	168	83
1 1/2"	GNP-44	242	118	168	83
2"	GNP-44	260	118	168	83
2 1/2"	GNP-94	333	139	204	103
3"	GNP-94	351	139	204	103
4"	GNP-198	409	163	268	121,5

GNP					
MED.	MOD. ACT	A	E	L	D
1/2"	GNP-24/S4	175	102	147	71,5
3/4"	GNP-44/S4	202	117,5	168	83
1"	GNP-44/S5	209	117,5	168	83
1 1/4"	GNP-60/S5	238,5	129,5	184	92
1 1/2"	GNP-94/S5	263	138,5	204	103
2"	GNP-135/S5	289	147	262	108,5
2 1/2"	GNP-198/S4	357	163	268	121,5
3"	GNP-300/S5	397,5	185	296	142
4"	GNP-513/S5	447,5	201,5	390	152

CÓDIGO CODE	MEDIDA SIZE	TIPO ACT. ACT. TYPE	PESO WEIGHT	P.V.P. € PRICE €
-------------	-------------	---------------------	-------------	------------------

GNP Doble efecto / GNP Double acting				
5052 04 122	1/2"	GNP-14	1.35	302,20
5052 05 122	3/4"	GNP-14	-	-
5052 06 122	1"	GNP-14	2.6	367,34
5052 07 128	1 1/4"	GNP-44	3.92	574,88
5052 08 128	1 1/2"	GNP-44	4.5	597,09
5052 09 128	2"	GNP-44	5.7	741,11
5052 10 142	2 1/2"	GNP-94	11.8	1112,65
5052 11 142	3"	GNP-94	16.7	1360,46
5052 12 150	4"	GNP-198	26	1951,94
GNP Simple efecto / GNP Spring Return				
5052 04 126	1/2"	GNP-24/S4	1.89	352,18
5052 05 132	3/4"	GNP-44/S4	-	-
5052 06 136	1"	GNP-44/S5	3.22	434,71
5052 07 140	1 1/4"	GNP-60/S5	4.65	642,17
5052 08 144	1 1/2"	GNP-94/S5	6.1	692,26
5052 09 148	2"	GNP-135/S5	11.68	863,63
5052 10 152	2 1/2"	GNP-198/S4	15.3	1256,68
5052 11 160	3"	GNP-300/S5	23	1607,53
5052 12 164	4"	GNP-513/S5	27.5	2213,94

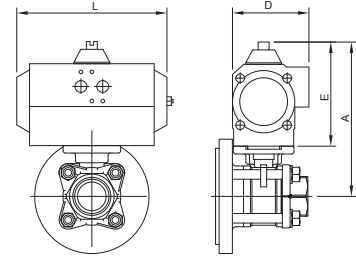

Información técnica
Technical information

Ref.5053



Válvula esfera paso total fondo de cubas / Actuador GNP

Const. acero inox. CF8M (316) y 316l (fondo de cubas). Extremo butt weld ANSI B 16.25 y fondo de cubas. Asientos PTFE + 15% FV. Tórica eje vitón. PN 63. Temp. -25°C +180°C. Montaje directo s/ISO 5211. Mando manual por palanca con sistema de bloqueo. Con actuador GNP.

Tank bottom full bore ball valve / GNP Actuator

Const. stainless steel CF8M (316) and 316l (tank bottom). Ends: butt weld ANSI B 16.25 and tank bottom. Seats: PTFE + 15% FV. O'ring stem: viton. PN 63. Temp. -25°C +180°C. Direct assembling ISO 5211. Manually operated by handle with locking system. With GNP actuator.

GNP					
MED.	MOD. ACT	A	E	L	D
1/2"	GNP-14	163	90	122	65
3/4"	GNP-14	174	90	122	65
1"	GNP-14	181	90	122	65
1 1/4"	GNP-44	227	118	168	83
1 1/2"	GNP-44	242	118	168	83
2"	GNP-44	260	118	168	83
2 1/2"	GNP-94	333	139	204	103
3"	GNP-94	351	139	204	103
4"	GNP-198	409	163	268	121,5

GNP					
MED.	MOD. ACT	A	E	L	D
1/2"	GNP-24/S4	175	102	147	71,5
3/4"	GNP-44/S4	202	117,5	168	83
1"	GNP-44/S5	209	117,5	168	83
1 1/4"	GNP-60/S5	238,5	129,5	184	92
1 1/2"	GNP-94/S5	263	138,5	204	103
2"	GNP-135/S5	289	147	262	108,5
2 1/2"	GNP-198/S4	357	163	268	121,5
3"	GNP-300/S5	397,5	185	296	142
4"	GNP-513/S5	447,5	201,5	390	152

GNP Doble efecto / GNP Double acting				
5053 04 122	1/2"	GNP-14	1.35	302,20
5053 05 122	3/4"	GNP-14	-	-
5053 06 122	1"	GNP-14	2.34	367,34
5053 07 128	1 1/4"	GNP-44	-	-
5053 08 128	1 1/2"	GNP-44	6.95	597,09
5053 09 128	2"	GNP-44	7.8	741,11
5053 10 142	2 1/2"	GNP-94	13.42	1112,65
5053 11 142	3"	GNP-94	13.42	1360,46
5053 12 150	4"	GNP-198	27.7	1951,94
GNP Simple efecto / GNP Spring Return				
5053 04 126	1/2"	GNP-24/S4	1.9	352,18
5053 05 132	3/4"	GNP-44/S4	3.5	386,27
5053 06 136	1"	GNP-44/S5	4.32	434,71
5053 07 140	1 1/4"	GNP-60/S5	-	-
5053 08 144	1 1/2"	GNP-94/S5	6.95	692,26
5053 09 148	2"	GNP-135/S5	9.95	863,64
5053 10 152	2 1/2"	GNP-198/S4	16.92	1256,68
5053 11 160	3"	GNP-300/S5	24	1607,53
5053 12 164	4"	GNP-513/S5	37.5	2213,94

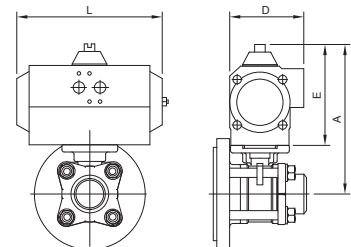

Información técnica
Technical information

Ref.5540E



Válvula esfera 3 vías bridada "L" / Actuador GNP

Características de la válvula ver artículo 2540E

"L" ways ball valve with flanges / GNP Actuator

Valve characteristics see article 2540E

GNP					
MED.	MOD. ACT	A	E	L	D
1"	GNP-44	178	117,5	168	83
1 1/4"	GNP-44	193,5	117,5	168	83
1 1/2"	GNP-60	186	129,5	184	92
2"	GNP-94	223,5	138,5	204	103
2 1/2"	GNP-135	238	147	262	108,5
3"	GNP-198	285,5	163	268	121,5
4"	GNP-513	347	201,5	390	152

GNP					
MED.	MOD. ACT	A	E	L	D
1"	GNP-84/S5	199	138,5	204	103
1 1/4"	GNP-135/S5	223	147	262	108,5
1 1/2"	GNP-198/S4	241,5	163	268	121,5
2"	GNP-300/S5	270	185	296	142
2 1/2"	GNP-513/S5	311,5	201,5	390	152
3"	GNP-800/S5	349,5	227	454	174
4"	GNP-1280/S5	405,5	260	525	206



CÓDIGO CODE	MEDIDA SIZE	TIPO ACT. ACT. TYPE	PESO WEIGHT	P.V.P. € PRICE €
----------------	----------------	------------------------	----------------	---------------------

GNP Doble efecto / GNP Double acting				
5540E 06 128	1"	GNP-44	8.66	495,76
5540E 07 128	1 1/4"	GNP-44	12.52	594,54
5540E 08 138	1 1/2"	GNP-60	16.66	738,06
5540E 09 142	2"	GNP-94	21.7	962,42
5540E 10 146	2 1/2"	GNP-135	27.7	1668,27
5540E 11 150	3"	GNP-198	47.9	2448,15
5540E 12 162	4"	GNP-513	57.94	3842,29
GNP Simple efecto / GNP Spring return				
5540E 06 144	1"	GNP-94/S5	10.16	588,29
5540E 07 148	1 1/4"	GNP-135/S5	15.96	694,41
5540E 08 152	1 1/2"	GNP-198/S4	20.66	898,07
5540E 09 160	2"	GNP-300/S5	28.8	1149,63
5540E 10 164	2 1/4"	GNP-513/S5	37.1	1920,12
5540E 11 168	3"	GNP-800/S5	65.3	2885,56
5540E 12 172	4"	GNP-1280/S5	92.04	4282,43

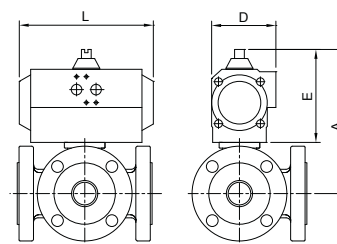

Información técnica
Technical information

Ref.5541E

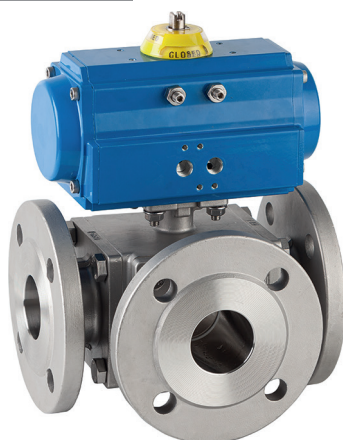

Válvula esfera 3 vías bridada "T"

Características de la válvula ver artículo 2541E.

"T" 3 ways ball valve with flanges

Valve characteristics see article 2541E.

GNP					
MED.	MOD. ACT	A	E	L	D
1"	GNP-44	178	117,5	168	83
1 1/4"	GNP-44	193,5	117,5	168	83
1 1/2"	GNP-60	186	129,5	184	92
2"	GNP-94	223,5	138,5	204	103
2 1/2"	GNP-135	238	147	262	108,5
3"	GNP-198	285,5	163	268	121,5
4"	GNP-513	347	201,5	390	152

GNP					
MED.	MOD. ACT	A	E	L	D
1"	GNP-94/S5	199	138,5	204	103
1 1/4"	GNP-135/S5	223	147	262	108,5
1 1/2"	GNP-198/S4	241,5	163	268	121,5
2"	GNP-300/S5	270	185	296	142
2 1/2"	GNP-513/S5	311,5	201,5	390	152
3"	GNP-800/S5	349,5	227	454	174
4"	GNP-1280/S5	405,5	260	525	206



GNP Doble efecto / GNP Double acting				
5541E 06 128	1"	GNP-44	8.64	495,76
5541E 07 128	1 1/4"	GNP-44	12.44	594,54
5541E 08 138	1 1/2"	GNP-60	17.4	738,06
5541E 09 142	2"	GNP-94	21.7	962,42
5541E 10 146	2 1/2"	GNP-135	27.7	1668,27
5541E 11 150	3"	GNP-198	37.2	2448,15
5541E 12 162	4"	GNP-513	55.24	3842,29
GNP simple efecto / GNP Spring return				
5541E 06 144	1"	GNP-94/S5	10.14	588,29
5541E 07 148	1 1/4"	GNP-135/S5	15.84	694,41
5541E 08 152	1 1/2"	GNP-198/S4	21.4	898,07
5541E 09 160	2"	GNP-300/S5	28.62	1149,63
5541E 10 164	2 1/2"	GNP-513/S5	42.05	1920,12
5541E 11 168	3"	GNP-800/S5	54.6	2885,56
5541E 12 172	4"	GNP-1280/S5	92.04	4282,43

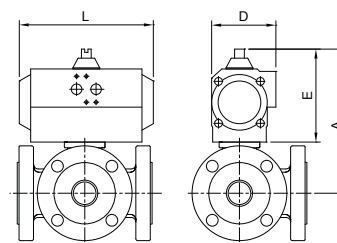

Información técnica
Technical information

Ref.5544



Válvula esfera 3 vías bridada "L"

Características de la válvula ver artículo 2544.

"L" 3 ways ball valve with flanges
Valve characteristics see article 2544.

GNP					
MED.	MOD. ACT	A	E	L	D
1"	GNP-44	178	117,5	168	83
1 1/4"	GNP-44	193,5	117,5	168	83
1 1/2"	GNP-60	186	129,5	184	92
2"	GNP-94	223,5	138,5	204	103
2 1/2"	GNP-135	238	147	262	108,5
3"	GNP-198	285,5	163	268	121,5
4"	GNP-513	347	201,5	390	152

GNP					
MED.	MOD. ACT	A	E	L	D
1"	GNP-94/S5	199	138,5	204	103
1 1/4"	GNP-135/S5	223	147	262	108,5
1 1/2"	GNP-198/S4	241,5	163	268	121,5
2"	GNP-300/S5	270	185	296	142
2 1/2"	GNP-513/S5	311,5	201,5	390	152
3"	GNP-800/S5	349,5	227	454	174
4"	GNP-1280/S5	405,5	260	525	206



CÓDIGO CODE	MEDIDA SIZE	TIPO ACT. ACT. TYPE	PESO WEIGHT	P.V.P. € PRICE €
----------------	----------------	------------------------	----------------	---------------------

GNP Doble efecto / GNP Double acting				
5544 06 128	1"	GNP-44	8.66	423,94
5544 07 128	1 1/4"	GNP-44	12.44	498,33
5544 08 138	1 1/2"	GNP-60	16.48	608,54
5544 09 142	2"	GNP-94	21.52	799,29
5544 10 146	2 1/2"	GNP-135	27	1278,34
5544 11 150	3"	GNP-198	37.2	1781,02
5544 12 162	4"	GNP-513	55.24	2753,28
GNP Simple efecto / GNP Spring return				
5544 06 144	1"	GNP-94/S5	10.16	512,95
5544 07 148	1 1/4"	GNP-135/S5	15.96	622,77
5544 08 152	1 1/2"	GNP-198/S4	20.66	756,93
5544 09 160	2"	GNP-300/S5	28.8	1040,08
5544 10 164	2 1/2"	GNP-513/S5	37.1	1668,20
5544 11 168	3"	GNP-800/S5	55.4	2340,68
5544 12 172	4"	GNP-1280/S5	92.04	3547,00

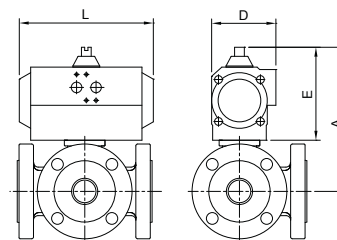

Información técnica
Technical information

Ref.5545



Válvula esfera 3 vías bridada "T" / Actuador GNP

Características de la válvula ver artículo 2545.

"T" 3 ways ball valve with flanges / GNP Actuator
Valve characteristics see article 2545.

GNP					
MED.	MOD. ACT	A	E	L	D
1"	GNP-44	178	117,5	168	83
1 1/4"	GNP-44	193,5	117,5	168	83
1 1/2"	GNP-60	186	129,5	184	92
2"	GNP-94	223,5	138,5	204	103
2 1/2"	GNP-135	238	147	262	108,5
3"	GNP-198	285,5	163	268	121,5
4"	GNP-513	347	201,5	390	152

GNP					
MED.	MOD. ACT	A	E	L	D
1"	GNP-94/S5	199	138,5	204	103
1 1/4"	GNP-135/S5	223	147	262	108,5
1 1/2"	GNP-198/S4	241,5	163	268	121,5
2"	GNP-300/S5	270	185	296	142
2 1/2"	GNP-513/S5	311,5	201,5	390	152
3"	GNP800/S5	349,5	227	454	174
4"	GNP1280/S5	405,5	260	525	206



GNP Doble efecto / GNP Double acting				
5545 06 128	1"	GNP-44	8.64	423,94
5545 07 128	1 1/4"	GNP-44	12.44	498,33
5545 08 138	1 1/2"	GNP-60	27	608,54
5545 09 142	2"	GNP-94	21.52	799,29
5545 10 146	2 1/2"	GNP-135	27	1278,34
5545 11 150	3"	GNP-198	37.2	1781,02
5545 12 162	4"	GNP-513	55.24	2753,28
GNP Simple efecto / GNP Spring return				
5545 06 144	1"	GNP-94/S5	10.14	512,95
5545 07 148	1 1/4"	GNP-135/S5	15.84	622,77
5545 08 152	1 1/2"	GNP-198/S4	20.8	756,93
5545 09 160	2"	GNP-300/S5	28.62	1040,08
5545 10 164	2 1/2"	GNP-513/S5	36.4	1668,20
5545 11 168	3"	GNP-800/S5	54.6	2340,68
5545 12 172	4"	GNP-1280/S5	89.34	3547,00

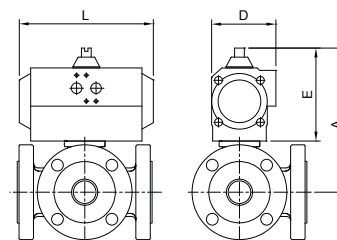

Información técnica
Technical information

Ref.5525

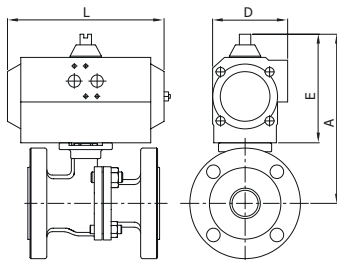

Información técnica
Technical information

Válvula esfera 2 piezas bridada

Características de la válvula ver artículo 2525.

2 piezas full bore ball valve

Valve characteristics see article 2525.

GN					
MED.	MOD. ACT	A	E	L	D
1/2"	GN-15	160	111	165	81
3/4"	GN-15	165	111	165	81
1"	GN-15	171	111	165	81
1 1/4"	GN-15	184	111	165	81
1 1/2"	GN-15	189	111	165	81
2"	GN-20	214	128	177	96
2 1/2"	GN-20	226	128	177	96
3"	GN-25	241	128	239	96
4"	GN-35	320	184	246	131
5"	GN-40	384	184	290	131
6"	GN-45	448	198	351	145
8"	GN-55	632	232	418	181

GN					
MED.	MOD. ACT	A	E	L	D
1/2"	GN-15/S3	160	111	165	81
3/4"	GN-15/S4	160	111	165	81
1"	GN-20/S3	188	128	177	96
1 1/4"	GN-20/S4	201	128	177	96
1 1/2"	GN-25/S4	206	128	239	96
2"	GN-30/S4	233	147	230	114
2 1/2"	GN-35/S3	282	184	246	131
3"	GN-40/S4	297	184	290	131
4"	GN-45/S4	334	198	351	145
5"	GN-55/S4	432	232	418	181
6"	GN-55/S5	482	232	418	181
8"	GN-65/S5	687	287	502	230

CÓDIGO CODE	MEDIDA SIZE	TIPO ACT. ACT. TYPE	PESO WEIGHT	P.V.P. € PRICE €
----------------	----------------	------------------------	----------------	---------------------

Gen-Air Doble efecto / Gen-Air Double acting				
5525 04 62	1/2"	GN-15	4.03	211,32
5525 05 63	3/4"	GN-15	4.63	220,41
5525 06 63	1"	GN-15	5.63	230,99
5525 07 63	1 1/4"	GN-15	6.92	246,92
5525 08 63	1 1/2"	GN-15	8.63	277,87
5525 09 64	2"	GN-20	12.07	362,83
5525 10 64	2 1/2"	GN-20	15.37	438,54
5525 11 65	3"	GN-25	20.7	531,68
5525 12 67	4"	GN-35	29.68	748,92
5525 13 68	5"	GN-40	54.53	1682,01
5525 14 69	6"	GN-45	74.96	2250,04
5525 16 84	8"	GN-55	110.08	4130,89

Gen-Air Simple efecto / Gen-Air Spring return				
5525 04 73	1/2"	GN-15/S3	4.22	234,99
5525 05 74	3/4"	GN-15/S4	4.82	250,78
5525 06 75	1"	GN-20/S3	7.05	290,86
5525 07 76	1 1/4"	GN-20/S4	8.55	320,20
5525 08 77	1 1/2"	GN-25/S4	11.28	375,23
5525 09 78	2"	GN-30/S4	14.77	440,06
5525 10 79	2 1/2"	GN-35/S3	21.52	596,61
5525 11 80	3"	GN-40/S4	27.41	729,23
5525 12 81	4"	GN-45/S4	37.12	924,84
5525 13 82	5"	GN-55/S4	72.5	2178,13
5525 14 83	6"	GN-55/S5	89.5	2704,12
5525 16 93	8"	GN-65/S5	140.3	4937,43

Ref.5525

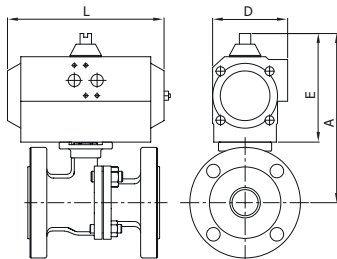

Información técnica
Technical information

Válvula esfera 2 piezas bridada

Características de la válvula ver artículo 2525.

2 piezas full bore ball valve

Valve characteristics see article 2525.

GNP					
MED.	MOD. ACT	A	E	L	D
1/2"	GNP-44	166,5	117,5	168	83
3/4"	GNP-44	171,5	117,5	168	83
1"	GNP-44	177,5	117,5	168	83
1 1/4"	GNP-44	190,5	117,5	168	83
1 1/2"	GNP-44	195,5	117,5	168	83
2"	GNP-60	215,5	129,5	184	92
2 1/2"	GNP-94	236,5	138,5	204	103
3"	GNP-94	251,5	138,5	204	103
4"	GNP-198	299	163	268	121,5
5"	GNP-300	385	185	296	142
6"	GNP-513	451,5	201,5	390	152
8"	GNP-800	627	227	454	174

GNP					
MED.	MOD. ACT	A	E	L	D
1/2"	GNP-24/S4	151	102	147	71,5
3/4"	GNP-44/S4	171,5	117,5	168	83
1"	GNP-60/S5	189,5	129,5	184	92
1 1/4"	GNP-60/S5	202,5	129,5	184	92
1 1/2"	GNP-94/S5	216,5	138,5	204	103
2"	GNP-135/S5	233	147	262	108,5
2 1/2"	GNP-198/S5	261	163	268	121,5
3"	GNP-300/S5	298	185	296	142
4"	GNP-513/S5	337,5	201,5	390	152
5"	GNP-1280/S5	460	260	525	206
6"	GNP-1280/S5	510	260	525	206
8"	GNP-2300/S5	718	318	610	260

GNP Doble efecto / GNP Double acting				
5525 04 130	1/2"	GNP-44	4.3	200,43
5525 05 128	3/4"	GNP-44	4.9	208,60
5525 06 128	1"	GNP-44	5.9	231,82
5525 07 128	1 1/4"	GNP-44	7.4	233,34
5525 08 128	1 1/2"	GNP-44	8.9	262,60
5525 09 138	2"	GNP-60	11.9	336,15
5525 10 142	2 1/2"	GNP-94	15.75	406,29
5525 11 142	3"	GNP-94	20	492,59
5525 12 150	4"	GNP-198	28	693,84
5525 13 158	5"	GNP-300	54.5	1558,32
5525 14 162	6"	GNP-513	74.5	2084,59
5525 16 166	8"	GNP-800	106.9	3827,17

GNP Simple efecto / GNP Spring return				
5525 04 126	1/2"	GNP-24/S4	3.7	217,72
5525 05 132	3/4"	GNP-44/S4	5	231,65
5525 06 140	1"	GNP-60/S5	6.7	269,46
5525 07 140	1 1/4"	GNP-60/S5	8.74	296,65
5525 08 144	1 1/2"	GNP-94/S5	10.4	347,63
5525 09 148	2"	GNP-135/S5	14.7	407,68
5525 10 154	2 1/2"	GNP-198/S5	19.2	-
5525 11 160	3"	GNP-300/S5	27.1	675,61
5525 12 164	4"	GNP-513/S5	36.5	933,97
5525 13 172	5"	GNP-1280/S5	91.6	2245,04
5525 14 172	6"	GNP-1280/S5	108.6	2720,03
5525 16 178	8"	GNP-2300/S5	161.2	5099,09

Ref.5526A

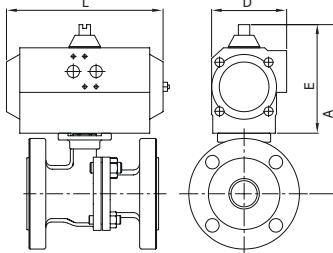

Válvula esfera 2 piezas bridada

Características de la válvula ver artículo 2526A.

2 pieces ball valve with flanges
Valve characteristics see article 2526A.

GN					
MED.	MOD. ACT	A	E	L	D
1/2"	GN-05	157	101	119	67
3/4"	GN-05	160	101	119	67
1"	GN-05	160	101	119	67
1 1/4"	GN-15	180	111	165	81
1 1/2"	GN-15	180	111	165	81
2"	GN-17	195	111	197	81
2 1/2"	GN-20	245	128	177	96
3"	GN-25	258	128	239	96
4"	GN-35	328	184	246	131
6"	GN-50	522	232	361	181

GN					
MED.	MOD. ACT	A	E	L	D
1/2"	GN-15/S3	160	111	165	81
3/4"	GN-15/S4	165	111	165	81
1"	GN-17/S3	169	111	197	81
1 1/4"	GN-20/S4	200	128	177	96
1 1/2"	GN-25/S4	205	128	239	96
2"	GN-30/S4	231	147	230	114
2 1/2"	GN-35/S3	303	184	246	131
3"	GN-40/S4	314	184	290	131
4"	GN-45/S4	343	198	351	145
6"	GN-55/S5	482	232	418	181



Información técnica
Technical information

CÓDIGO CODE	MEDIDA SIZE	TIPO ACT. ACT. TYPE	PESO WEIGHT	P.V.P. € PRICE €
----------------	----------------	------------------------	----------------	---------------------

Gen-Air Doble efecto / Gen-Air Double acting				
5526A 04 44	1/2"	GN-05	2.3	188,62
5526A 05 44	3/4"	GN-05	2.95	204,93
5526A 06 44	1"	GN-05	3.7	230,32
5526A 07 63	1 1/4"	GN-15	6	291,13
5526A 08 63	1 1/2"	GN-15	7.63	340,74
5526A 09 52	2"	GN-17	10.75	445,24
5526A 10 64	2 1/2"	GN-20	16.27	651,22
5526A 11 65	3"	GN-25	21.8	816,21
5526A 12 67	4"	GN-35	37.36	1356,76
5526A 14 97	6"	GN-50	74.65	2892,37

Gen-Air Simple efecto / Gen-Air Spring return				
5526A 04 73	1/2"	GN-15/S3	3.47	241,59
5526A 05 74	3/4"	GN-15/S4	4.12	266,53
5526A 06 49	1"	GN-17/S3	5.44	309,78
5526A 07 76	1 1/4"	GN-20/S4	7.15	373,87
5526A 08 77	1 1/2"	GN-25/S4	10.28	454,20
5526A 09 78	2"	GN-30/S4	13.97	567,06
5526A 10 79	2 1/2"	GN-35/S3	22.42	844,14
5526A 11 80	3"	GN-40/S4	28.51	1043,04
5526A 12 81	4"	GN-45/S4	45.52	1558,35
5526A 14 83	6"	GN-55/S5	82.3	3186,93

Ref.5526A

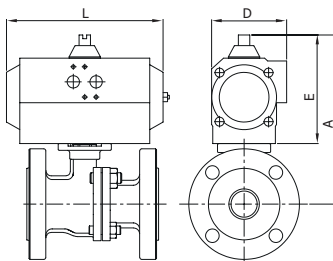
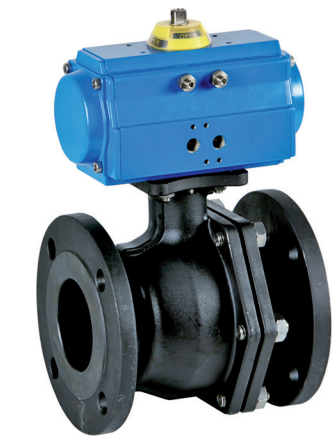

Válvula esfera 2 piezas bridada

Características de la válvula ver artículo 2526A.

2 pieces ball valve with flanges
Valve characteristics see article 2526A.

GNP					
MED.	MOD. ACT	A	E	L	D
1/2"	GNP-14	130	80	122	65
3/4"	GNP-14	137	80	122	65
1"	GNP-14	137	80	122	65
1 1/4"	GNP-44	189	118	168	83
1 1/2"	GNP-44	201	118	168	83
2"	GNP-44	201	118	168	83
2 1/2"	GNP-94	258	139	204	103
3"	GNP-94	268	139	204	103
4"	GNP-198	308	163	268	121,5
6"	GNP-513	451	201	390	152

GNP					
MED.	MOD. ACT	A	E	L	D
1/2"	GNP-44/S4	165	117,5	168	83
3/4"	GNP-44/S4	175	117,5	168	83
1"	GNP-44/S5	175	117,5	168	83
1 1/4"	GNP-60/S5	201	129,5	184	92
1 1/2"	GNP-94/S5	215	138,5	204	103
2"	GNP-135/S5	230	147	262	108,5
2 1/2"	GNP-198/S4	281	163	268	121,5
3"	GNP-300/S5	315	185	296	142
4"	GNP-513/S5	347	201,5	390	152
6"	GNP-1280/S5	510	260	525	206



Información técnica
Technical information

GNP Doble efecto / GNP Double acting				
5526A 04 122	1/2"	GNP-14	2.25	178,25
5526A 05 122	3/4"	GNP-14	2.9	193,66
5526A 06 122	1"	GNP-14	3.65	217,64
5526A 07 128	1 1/4"	GNP-44	6.27	275,12
5526A 08 128	1 1/2"	GNP-44	7.9	321,98
5526A 09 128	2"	GNP-44	10.5	420,76
5526A 10 142	2 1/2"	GNP-94	16.7	603,33
5526A 11 142	3"	GNP-94	21.1	756,20
5526A 12 150	4"	GNP-198	35.68	1256,99
5526A 14 162	6"	GNP-513	67.2	2344,94

GNP Simple efecto / GNP Spring return				
5526A 04 134	1/2"	GNP-44/S4	3.65	223,83
5526A 05 132	3/4"	GNP-44/S4	4.3	246,94
5526A 06 136	1"	GNP-44/S5	5.05	292,72
5526A 07 140	1 1/4"	GNP-60/S5	6.8	346,38
5526A 08 144	1 1/2"	GNP-94/S5	9.4	420,78
5526A 09 148	2"	GNP-135/S5	13.9	525,36
5526A 10 152	2 1/2"	GNP-198/S4	20.1	782,07
5526A 11 160	3"	GNP-300/S5	28.2	966,36
5526A 12 164	4"	GNP-513/S5	44.9	1443,75
5526A 14 172	6"	GNP-1280/S5	101.3	3069,13

Ref.5528

Válvula esfera 2 piezas bridada / Actuador Gen-Air

Características de la válvula ver artículo 2528.

2 piezas full bore ball valve / Gen-Air Actuator

Valve characteristics see article 2528.

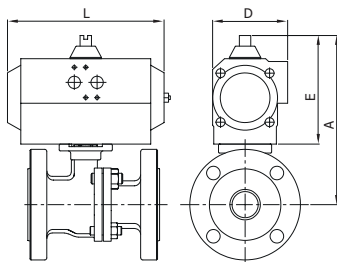
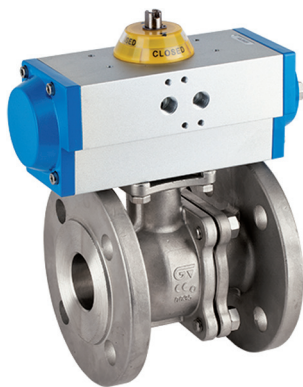

GN					
MED.	MOD. ACT	A	E	L	D
1/2"	GN-05	147,5	101	119	67
3/4"	GN-05	152,5	101	119	67
1"	GN-05	158,5	101	119	67
1 1/4"	GN-15	182,0	111	165	81
1 1/2"	GN-15	187,0	111	165	81
2"	GN-17	194,0	111	197	81
2 1/2"	GN-20	246,5	128	177	96
3"	GN-25	257,5	128	239	96
4"	GN-35	329	184	246	131
5"	GN-50	432	232	361	181
6"	GN-50	482	232	361	181
8"	GN-55	484	232	418	181

GN					
MED.	MOD. ACT	A	E	L	D
1/2"	GN-15/S3	160	111	165	81
3/4"	GN-15/S4	165	111	165	81
1"	GN-20/S3	188	128	177	96
1 1/4"	GN-20/S4	201	128	177	96
1 1/2"	GN-25/S4	206	128	239	96
2"	GN-30/S4	233	147	230	114
2 1/2"	GN-35/S3	282	184	246	131
3"	GN-40/S4	297	184	290	131
4"	GN-45/S4	334	198	351	145
5"	GN-55/S4	432	232	418	181
6"	GN-55/S5	482	232	418	181
8"	GN-65/S5	544	287	502	230



Información técnica
Technical information

CÓDIGO CODE	MEDIDA SIZE	TIPO ACT. ACT. TYPE	PESO WEIGHT	P.V.P. € PRICE €
----------------	----------------	------------------------	----------------	---------------------

Gen-Air Doble efecto / Gen-Air Double acting

5528 04 44	1/2"	GN-05	3.05	245,18
5528 05 44	3/4"	GN-05	3.9	268,22
5528 06 44	1"	GN-05	4.6	304,35
5528 07 63	1 1/4"	GN-15	7.58	401,96
5528 08 63	1 1/2"	GN-15	8.83	438,81
5528 09 52	2"	GN-17	11.85	564,94
5528 10 64	2 1/2"	GN-20	17.62	835,22
5528 11 65	3"	GN-25	22.85	1007,81
5528 12 67	4"	GN-35	33.11	1523,54
5528 13 97	5"	GN-50	70.13	-
5528 14 97	6"	GN-50	0.01	4258,60
5528 16 84	8"	GN-55	132.98	8782,93

Gen-Air Simple efecto / Gen-Air Spring return

5528 04 73	1/2"	GN-15/S3	4.22	287,59
5528 05 74	3/4"	GN-15/S4	5.07	315,99
5528 06 49	1"	GN-17/S4	6.34	352,81
5528 07 76	1 1/4"	GN-20/S4	9	485,16
5528 08 77	1 1/2"	GN-25/S4	11.48	544,35
5528 09 78	2"	GN-30/S4	15.07	673,10
5528 10 79	2 1/2"	GN-35/S3	23.77	1014,40
5528 11 80	3"	GN-40/S4	29.56	1216,08
5528 12 81	4"	GN-45/S4	41.27	1650,68
5528 13 82	5"	GN-55/S4	78.65	3581,04
5528 14 83	6"	GN-55/S5	97.85	4511,66
5528 16 93	8"	GN-65/S5	163.75	9542,76

Ref.5528

Válvula de esfera 2 piezas bridada

Características de la válvula ver artículo 2528.

2 piezas full bore ball valve

Valve characteristics see article 2528.

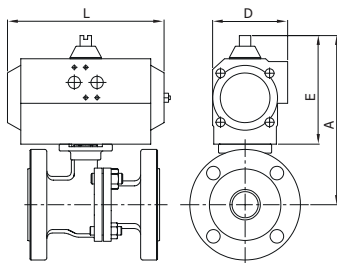
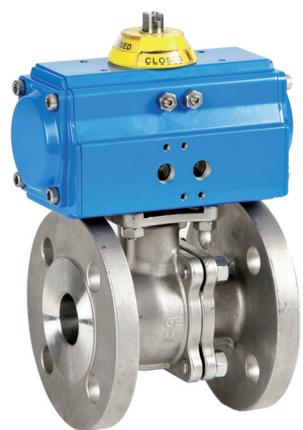

GNP					
MED.	MOD. ACT	A	E	L	D
1/2"	GNP-14	126,5	80	122	65
3/4"	GNP-14	131,5	80	122	65
1"	GNP-14	137,5	80	122	65
1 1/4"	GNP-44	189	117,5	168	83
1 1/2"	GNP-44	194	117,5	168	83
2"	GNP-44	201	117,5	168	83
2 1/2"	GNP-94	258	138,5	203	103
3"	GNP-94	268	138,5	204	103
4"	GNP-198	308	163	268	121,5
5"	GNP-513	401,5	201,5	390	152
6"	GNP-513	451,5	201,5	390	152
8"	GNP-800	484	227	454	174

GNP					
MED.	MOD. ACT	A	E	L	D
1/2"	GNP-24/S4	148	102	147	71,5
3/4"	GNP-44/S4	169	117,5	168	83
1"	GNP-44/S5	175	117,5	168	83
1 1/4"	GNP-60/S5	201	129,5	184	92
1 1/2"	GNP-94/S5	215	138,5	204	103
2"	GNP-135/S5	230,5	147	262	108,5
2 1/2"	GNP-198/S4	281,5	163	268	121,5
3"	GNP-300/S5	314,5	185	296	142
4"	GNP-513/S5	346,5	201,5	390	152
5"	GNP-1280/S5	460	260	525	206
6"	GNP-1280/S5	510	260	525	206
8"	GNP-2300/S5	575	318	610	260



Información técnica
Technical information

GNP Doble efecto / GNP Double acting

5528 04 122	1/2"	GNP-14	3	231,69
5528 05 122	3/4"	GNP-14	3.85	253,47
5528 06 122	1"	GNP-14	4.55	287,60
5528 07 128	1 1/4"	GNP-44	7.85	371,92
5528 08 128	1 1/2"	GNP-44	9.1	414,68
5528 09 128	2"	GNP-44	11.6	533,87
5528 10 142	2 1/2"	GNP-94	18.05	773,81
5528 11 142	3"	GNP-94	21.44	933,71
5528 12 150	4"	GNP-198	31.43	1408,69
5528 13 162	5"	GNP-513	51.4	2780,59
5528 14 162	6"	GNP-513	75.7	3679,18
5528 16 166	8"	GNP-800	129.8	7943,29

GNP Simple efecto / GNP Spring return

5528 04 126	1/2"	GNP-24/S4	4.5	263,63
5528 05 132	3/4"	GNP-44/S4	5.25	290,56
5528 06 136	1"	GNP-44/S5	5.95	333,42
5528 07 140	1 1/4"	GNP-60/S5	8.65	438,02
5528 08 144	1 1/2"	GNP-94/S5	10.6	504,34
5528 09 148	2"	GNP-135/S5	15	623,61
5528 10 152	2 1/2"	GNP-198/S4	21.45	939,83
5528 11 160	3"	GNP-300/S5	29.25	1129,02
5528 12 164	4"	GNP-513/S5	40.65	1597,99
5528 13 172	5"	GNP-1280/S5	97.75	3464,00
5528 14 172	6"	GNP-1280/S5	116.95	4424,45
5528 16 178	8"	GNP-2300/S5	184.65	9155,99

Ref.5528A

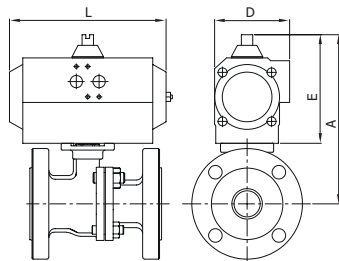
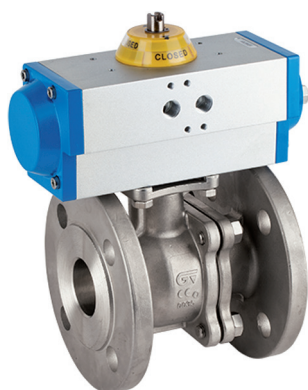

Válvula esfera 2 piezas bridada / Actuador Gen-Air
Características de la válvula ver artículo 2528A.

2 pieces ball valve with flanges / Gen-Air Actuator
Valve characteristics see article 2528A.

GN					
MED.	MOD. ACT	A	E	L	D
1/2"	GN-05	147,5	101	119	67
3/4"	GN-05	152,5	101	119	67
1"	GN-05	158,5	101	119	67
1 1/4"	GN-15	182,0	111	165	81
1 1/2"	GN-15	187,0	111	165	81
2"	GN-17	194,0	111	197	81
2 1/2"	GN-20	246,5	128	177	96
3"	GN-25	257,5	128	239	96
4"	GN-35	329	184	246	131
6"	GN-50	482	232	361	181
8"	GN-55	484	232	418	181

GN					
MED.	MOD. ACT	A	E	L	D
1/2"	GN-15/S3	157,5	111	165	81
3/4"	GN-15/S4	162,5	111	165	81
1"	GN-17/S4	168,5	111	197	81
1 1/4"	GN-20/S4	199,5	128	177	96
1 1/2"	GN-25/S4	204,5	128	239	96
2"	GN-30/S4	230,5	147	230	114
2 1/2"	GN-35/S3	302,5	184	246	131
3"	GN-40/S4	313,5	184	290	131
4"	GN-45/S4	343	198	351	145
6"	GN-55/S5	482	232	418	181
8"	GN-65/S5	544	287	502	230



Información técnica
Technical information

CÓDIGO CODE	MEDIDA SIZE	TIPO ACT. ACT. TYPE	PESO WEIGHT	P.V.P. € PRICE €
----------------	----------------	------------------------	----------------	---------------------

Gen-Air Doble efecto / Gen-Air Double acting

5528A 04 44	1/2"	GN-05	2.3	226,12
5528A 05 44	3/4"	GN-05	2.95	246,04
5528A 06 44	1"	GN-05	3.7	289,17
5528A 07 63	1 1/4"	GN-15	6	350,63
5528A 08 63	1 1/2"	GN-15	7.63	425,62
5528A 09 52	2"	GN-17	10.75	557,34
5528A 10 64	2 1/2"	GN-20	16.27	853,49
5528A 11 65	3"	GN-25	21.8	1058,97
5528A 12 67	4"	GN-35	37.36	1695,60
5528A 14 97	6"	GN-50	-	-
5528A 16 84	8"	GN-55	134.28	8723,80

Gen-Air Simple efecto / Gen-Air Spring return

5528A 04 73	1/2"	GN-15/S3	3.47	267,10
5528A 05 74	3/4"	GN-15/S4	4.12	294,76
5528A 06 49	1"	GN-17/S4	5.44	339,52
5528A 07 76	1 1/4"	GN-20/S4	7.15	432,80
5528A 08 77	1 1/2"	GN-25/S4	9.02	531,18
5528A 09 78	2"	GN-30/S4	12.7	660,18
5528A 10 79	2 1/2"	GN-35/S3	22.42	1023,06
5528A 11 80	3"	GN-40/S4	28.51	1278,41
5528A 12 81	4"	GN-45/S4	45.52	1861,57
5528A 14 83	6"	GN-55/S5	105	4925,27
5528A 16 93	8"	GN-65/S5	165.05	9561,47

Ref.5528A

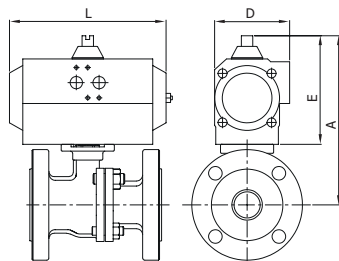
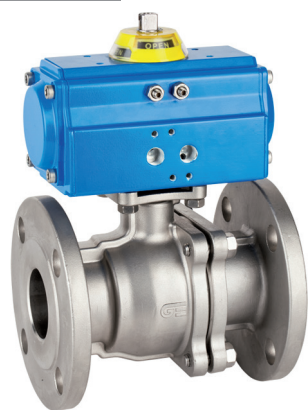

Válvula esfera 2 piezas bridada / Actuador GNP
Características de la válvula ver artículo 2528A.

2 pieces ball valve with flanges / GNP Actuator
Valve characteristics see article 2528A.

GNP					
MED.	MOD. ACT	A	E	L	D
1/2"	GNP-14	126,5	80	122	65
3/4"	GNP-14	131,5	80	122	65
1"	GNP-14	137,5	80	122	65
1 1/4"	GNP-44	189	117,5	168	83
1 1/2"	GNP-44	194	117,5	168	83
2"	GNP-44	201	117,5	168	83
2 1/2"	GNP-94	258	138,5	204	103
3"	GNP-94	268	138,5	204	103
4"	GNP-198	308	163	268	121,5
6"	GNP-513	451,5	201,5	390	152
8"	GNP-800	484	227	454	174

GNP					
MED.	MOD. ACT	A	E	L	D
1/2"	GNP-24/S4	148	102	147	71,5
3/4"	GNP-44/S4	169	117,5	168	83
1"	GNP-44/S5	175	117,5	168	83
1 1/4"	GNP-60/S5	201	129,5	184	92
1 1/2"	GNP-94/S5	215	138,5	204	103
2"	GNP-135/S5	230,5	147	262	108,5
2 1/2"	GNP-198/S4	281,5	163	268	121,5
3"	GNP-300/S5	314,5	185	296	142
4"	GNP-513/S5	346,5	201,5	390	152
6"	GNP-1280/S5	510	260	525	206
8"	GNP-2300/S5	575	318	610	260



Información técnica
Technical information

GNP Doble efecto / GNP Double acting

5528A 04 122	1/2"	GNP-14	2.25	213,69
5528A 05 122	3/4"	GNP-14	2.9	232,50
5528A 06 122	1"	GNP-14	3.65	273,26
5528A 07 128	1 1/4"	GNP-44	6.27	325,72
5528A 08 128	1 1/2"	GNP-44	7.9	388,79
5528A 09 128	2"	GNP-44	9.86	511,63
5528A 10 142	2 1/2"	GNP-94	16.7	790,75
5528A 11 142	3"	GNP-94	21.15	969,27
5528A 12 150	4"	GNP-198	35.68	1570,92
5528A 14 162	6"	GNP-513	66.2	4031,99
5528A 16 166	8"	GNP-800	131.1	8082,33

GNP Simple efecto / GNP Spring return

5528A 04 126	1/2"	GNP-24/S4	2.95	252,04
5528A 05 132	3/4"	GNP-44/S4	4.3	269,61
5528A 06 136	1"	GNP-44/S4	5.05	319,08
5528A 07 140	1 1/4"	GNP-60/S5	6.8	391,82
5528A 08 144	1 1/2"	GNP-94/S5	9.4	478,91
5528A 09 148	2"	GNP-135/S5	13.9	611,64
5528A 10 152	2 1/2"	GNP-198/S4	20.1	947,85
5528A 11 160	3"	GNP-300/S5	28.2	1184,02
5528A 12 164	4"	GNP-513/S5	44.9	1749,21
5528A 14 172	6"	GNP-1280/S5	124.1	4712,41
5528A 16 178	8"	GNP-2300/S5	185.95	9335,08

Ref. 5529

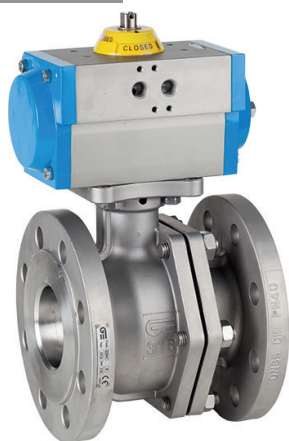

Válvula esfera 2 piezas bridada

Características de la válvula ver artículo 2529.

2 pieces ball valve with flanges

Valve characteristics see article 2529.

GN					
MED.	MOD. ACT	A	E	L	D
2 1/2"	GN-20	247	128	177	96
3"	GN-25	258	128	239	96
4"	GN-35	329	184	246	131
5"	GN-50	390	232	361	181
6"	GN-50	407	232	361	181

GN					
MED.	MOD. ACT	A	E	L	D
2 1/2"	GN-35/S3	303	184	246	131
3"	GN-40/S4	313	184	290	131
4"	GN-45/S4	343	198	351	145
5"	GN-55/S4	390	232	418	181
6"	GN-55/S5	407	232	418	181

CÓDIGO CODE	MEDIDA SIZE	TIPO ACT. ACT. TYPE	PESO WEIGHT	P.V.P. € PRICE €
----------------	----------------	------------------------	----------------	---------------------

Gen-Air Doble efecto / Gen-Air Double acting

5529 10 64	2 1/2"	GN-20	20.7	1191,34
5529 11 65	3"	GN-25	28.48	1470,50
5529 12 67	4"	GN-35	38.46	2037,48
5529 13 97	5"	GN-50	-	-
5529 14 97	6"	GN-50	84	5535,24

Gen-Air Simple efecto / Gen-Air Spring return

5529 10 79	2 1/2"	GN-35/S3	32.2	1376,47
5529 11 80	3"	GN-40/S4	35.51	1684,38
5529 12 81	4"	GN-45/S4	47.92	2227,54
5529 13 82	5"	GN-55/S4	99.55	4253,01
5529 14 83	6"	GN-55/S5	118.5	5639,47

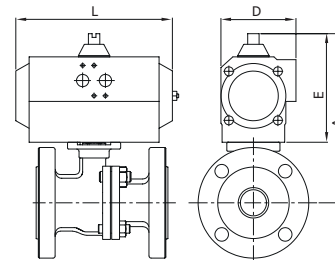

Información técnica
Technical information

Ref. 5529

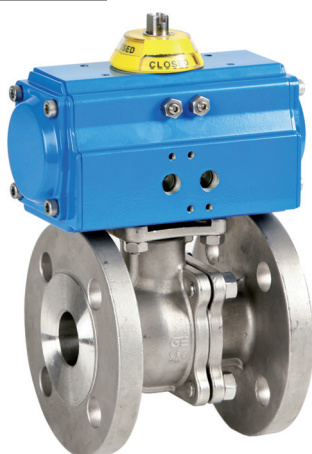

Válvula esfera 2 piezas bridada

Características de la válvula ver artículo 2529.

2 pieces ball valve with flanges

Valve characteristics see article 2529.

GNP					
MED.	MOD. ACT	A	E	L	D
2 1/2"	GNP-60	292,5	129,5	184	92
3"	GNP-94	303,5	138,5	204	103
4"	GNP-198	294	163	268	121,5
5"	GNP-513	402	201,5	390	152
6"	GNP-513	451,5	201,5	390	152

GNP					
MED.	MOD. ACT	A	E	L	D
2 1/2"	GNP-198/S5	326	163	268	121,5
3"	GNP-300/S5	350	185	296	142
4"	GNP-513/S5	385,5	201,5	390	152
5"	GNP-1280/S5	510	260	525	206
6"	GNP-1280/S5	510	260	525	206

GNP Doble efecto / GNP Double acting

5529 10 138	2 1/2"	GNP-60	20.53	1094,02
5529 11 142	3"	GNP-94	23.46	1353,00
5529 12 150	4"	GNP-198	36.78	1859,52
5529 13 162	5"	GNP-513	-	-
5529 14 162	6"	GNP-513	75.7	4676,37

GNP Simple efecto / GNP Spring return

5529 10 152	2 1/2"	GNP-198/S4	29.88	1235,50
5529 11 160	3"	GNP-300/S5	35.2	1545,80
5529 12 164	4"	GNP-513/S5	47.3	2044,29
5529 13 172	5"	GNP-1280/S5	118.65	4101,66
5529 14 172	6"	GNP-1280/S5	137.6	5189,54

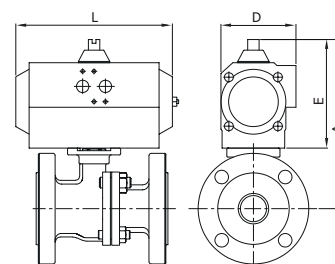

Información técnica
Technical information

Ref.5105



Válvula esfera 1 pieza tipo wafer

Características de la válvula ver artículo 2105.

1 piece full bore ball valve mounting between flanges PN-16 - wafer type

Valve characteristics see article 2105.

GNP					
MED.	MOD. ACT	A	E	L	D
1"	GNP-44	242,5	117,5	168	83
1 1/4"	GNP-60	274,5	129,5	184	92
1 1/2"	GNP-60	288,5	129,5	184	92
2"	GNP-60	302,5	129,5	184	92
2 1/2"	GNP-94	337,5	138,5	204	103
3"	GNP-94	367,5	138,5	204	103
4"	GNP-300	449	185	296	142

GNP					
MED.	MOD. ACT	A	E	L	D
1"	GNP-60/S5	254,5	129,5	184	92
1 1/4"	GNP-94/S5	283,5	138,5	204	103
1 1/2"	GNP-94/S5	297,5	138,5	204	103
2"	GNP-198/S4	336	163	268	121,5
2 1/2"	GNP-300/S5	384	185	296	142
3"	GNP-513/S5	430,5	201,5	390	152
4"	GNP-1280/S5	524	260	525	206

CÓDIGO CODE	MEDIDA SIZE	TIPO ACT. ACT. TYPE	PESO WEIGHT	P.V.P. € PRICE €
GNP Doble efecto / GNP Double acting				
5105 06 128	1"	GNP-44	4.83	285,68
5105 07 138	1 1/4"	GNP-60	6.5	355,60
5105 08 138	1 1/2"	GNP-60	9.2	382,94
5105 09 138	2"	GNP-60	10.7	418,84
5105 10 142	2 1/2"	GNP-94	18.3	643,07
5105 11 142	3"	GNP-94	23.3	728,53
5105 12 158	4"	GNP-300	38.7	1062,08
GNP Simple efecto / GNP Spring return				
5105 06 140	1"	GNP-60/S5	5.6	343,72
5105 07 144	1 1/4"	GNP-94/S5	6.17	405,78
5105 08 144	1 1/2"	GNP-94/S5	10.1	440,52
5105 09 152	2"	GNP-198/S4	14.7	549,02
5105 10 160	2 1/2"	GNP-300/S5	25.4	866,03
5105 11 164	3"	GNP-513/S5	34.8	1116,67
5105 12 172	4"	GNP-1280/S5	76	1874,15

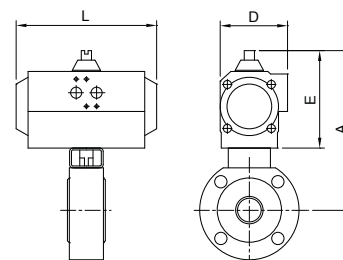

Información técnica
Technical information

Ref.5115



Válvula esfera 1 pieza tipo wafer con cámara de calefacción

Características de la válvula ver artículo 2115.

1 piece full bore ball valve with heating chamber. Mounting between flanges PN-16 wafer type

Valve characteristics see article 2115.

GNP					
MED.	MOD. ACT	A	E	L	D
1"	GNP-44	242,5	117,5	168	83
1 1/4"	GNP-60	274,5	129,5	184	92
1 1/2"	GNP-60	288,5	129,5	184	92
2"	GNP-60	302,5	129,5	184	92
2 1/2"	GNP-94	337,5	138,5	204	103
3"	GNP-94	367,5	138,5	204	103
4"	GNP-300	449	185	296	142

GNP					
MED.	MOD. ACT	A	E	L	D
1"	GNP-60/S5	254,5	129,5	184	92
1 1/4"	GNP-94/S5	283,5	138,5	204	103
1 1/2"	GNP-94/S5	297,5	138,5	204	103
2"	GNP-198/S4	336	163	268	121,5
2 1/2"	GNP-300/S5	384	185	296	142
3"	GNP-513/S5	430,5	201,5	390	152
4"	GNP-1280/S5	524	260	525	206

CÓDIGO CODE	MEDIDA SIZE	TIPO ACT. ACT. TYPE	PESO WEIGHT	P.V.P. € PRICE €
GNP Doble efecto / GNP Double acting				
5115 06 128	1"	GNP-44	4.83	394,39
5115 07 138	1 1/4"	GNP-60	6.5	477,21
5115 08 138	1 1/2"	GNP-60	9.2	534,59
5115 09 138	2"	GNP-60	10.7	588,29
5115 10 142	2 1/2"	GNP-94	18.3	868,65
5115 11 142	3"	GNP-94	23.3	979,71
5115 12 158	4"	GNP-300	38.7	1375,35
GNP Simple efecto / GNP Spring return				
5115 06 140	1"	GNP-60/S5	7.26	452,41
5115 07 144	1 1/4"	GNP-94/S5	6.17	527,39
5115 08 144	1 1/2"	GNP-94/S5	10.1	592,18
5115 09 152	2"	GNP-198/S4	14.7	718,48
5115 10 160	2 1/2"	GNP-300/S5	25.4	1091,61
5115 11 164	3"	GNP-513/S5	34.8	1367,85
5115 12 172	4"	GNP-1280/S5	76.5	2187,45

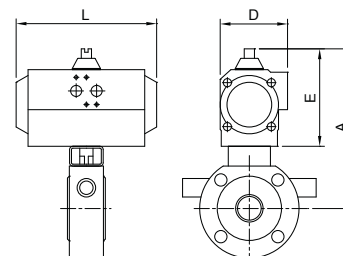

Información técnica
Technical information

Ref.5118



Válvula esfera 1 pieza tipo wafer

Características de la válvula ver artículo 2118.

1 piece full ball valve wafer type

Valve characteristics see article 2118.

GNP					
MED.	MOD. ACT	A	E	L	D
1/2"	GNP-14	185	80	122	65
3/4"	GNP-14	195	80	122	65
1"	GNP-14	138	80	122	65
1 1/4"	GNP-44	188	118	168	83
1 1/2"	GNP-44	195	118	168	83
2"	GNP-44	203	118	168	83
2 1/2"	GNP-94	234	139	204	103
3"	GNP-94	250	139	204	103
4"	GNP-198	286	163	268	121,5

GNP					
MED.	MOD. ACT	A	E	L	D
1/2"	GNP-44/S4	222,5	117,5	168	83
3/4"	GNP-44/S4	232,5	117,5	168	83
1"	GNP-44/S5	175,5	117,5	168	83
1 1/4"	GNP-60/S5	199,5	129,5	184	92
1 1/2"	GNP-94/S5	215,5	138,5	204	103
2"	GNP-135/S5	232	147	262	108,5
2 1/2"	GNP-198/S4	258	163	268	121,5
3"	GNP-300/S5	296	185	296	142
4"	GNP-513/S5	324,5	201,5	390	152

CÓDIGO CODE	MEDIDA SIZE	TIPO ACT. ACT. TYPE	PESO WEIGHT	P.V.P. € PRICE €
----------------	----------------	------------------------	----------------	---------------------

GNP Doble efecto / GNP Double acting				
5118 04 122	1/2"	GNP-14	2.45	247,53
5118 05 122	3/4"	GNP-14	2.65	265,40
5118 06 122	1"	GNP-14	3.28	290,98
5118 07 128	1 1/4"	GNP-44	5.82	383,59
5118 08 128	1 1/2"	GNP-44	6.45	432,04
5118 09 128	2"	GNP-44	9.2	500,87
5118 10 142	2 1/2"	GNP-94	12.9	798,67
5118 11 142	3"	GNP-94	13.6	963,55
5118 12 150	4"	GNP-198	23.18	1440,45
GNP Simple efecto / GNP Spring return				
5118 04 134	1/2"	GNP-44/S4	3.99	283,54
5118 05 134	3/4"	GNP-44/S4	4.05	307,57
5118 06 136	1"	GNP-44/S5	4.68	345,04
5118 07 140	1 1/4"	GNP-60/S5	6.35	430,32
5118 08 144	1 1/2"	GNP-94/S5	7.95	514,08
5118 09 148	2"	GNP-135/S5	13.5	608,93
5118 10 152	2 1/2"	GNP-198/S4	18.08	918,57
5118 11 160	3"	GNP-300/S5	25.36	1186,50
5118 12 164	4"	GNP-513/S5	32.4	1719,27

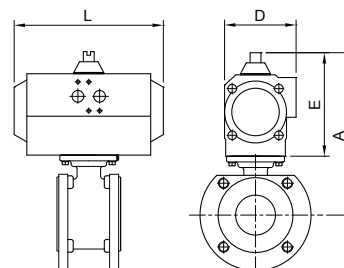

Información técnica
Technical information

Ref.5519

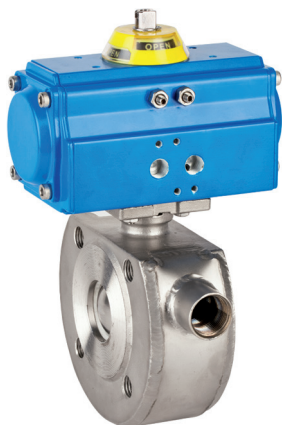

Válvula esfera 1 pieza tipo wafer con cámara de calefacción

Características de la válvula ver artículo 2119.

1 piece ball valve with heating chamber

Valve characteristics see article 2119.

GNP					
MED.	MOD. ACT	A	E	L	D
1/2"	GNP-14	185	80	122	65
3/4"	GNP-14	195	80	122	65
1"	GNP-14	138	80	122	65
1 1/4"	GNP-44	188	118	168	83
1 1/2"	GNP-44	195	118	168	83
2"	GNP-44	203	118	168	83
2 1/2"	GNP-94	234	139	204	103
3"	GNP-94	250	139	204	103
4"	GNP-198	286	163	268	121,5

GNP					
MED.	MOD. ACT	A	E	L	D
1/2"	GNP-44/S4	222,5	117,5	168	83
3/4"	GNP-44/S4	232,5	117,5	168	83
1"	GNP-44/S5	175,5	117,5	168	83
1 1/4"	GNP-60/S5	199,5	129,5	184	92
1 1/2"	GNP-94/S5	215,5	138,5	204	103
2"	GNP-135/S5	232	147	262	108,5
2 1/2"	GNP-198/S4	258	163	268	121,5
3"	GNP-300/S5	296	185	296	142
4"	GNP-513/S5	324,5	201,5	390	152

GNP Doble efecto / GNP Double acting				
5519 04 122	1/2"	GNP-14	2.55	521,94
5519 05 122	3/4"	GNP-14	2.76	541,40
5519 06 122	1"	GNP-14	3.43	646,15
5519 07 128	1 1/4"	GNP-44	6.07	752,77
5519 08 128	1 1/2"	GNP-44	8	812,35
5519 09 128	2"	GNP-44	8	901,20
5519 10 142	2 1/2"	GNP-94	14.35	1231,23
5519 11 142	3"	GNP-94	14.6	1431,40
5519 12 150	4"	GNP-198	24.48	1883,84
GNP Simple efecto / GNP Spring return				
5519 04 134	1/2"	GNP-44/S4	3.85	572,19
5519 05 134	3/4"	GNP-44/S4	4.05	591,64
5519 06 136	1"	GNP-44/S5	4.68	699,37
5519 07 140	1 1/4"	GNP-60/S5	6.35	810,17
5519 08 144	1 1/2"	GNP-94/S5	7.95	899,11
5519 09 148	2"	GNP-135/S5	10.95	1022,50
5519 10 152	2 1/2"	GNP-198/S4	14.4	1357,44
5519 11 160	3"	GNP-300/S5	20.7	1666,10
5519 12 164	4"	GNP-513/S5	32.4	2211,38

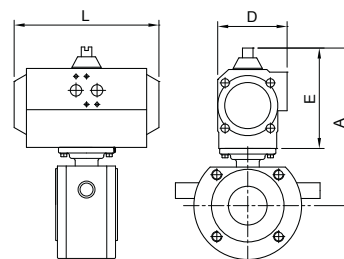

Información técnica
Technical information

Ref.5111



Válvula mariposa tipo wafer

Características de la válvula ver artículo 2101.

Butterfly valve wafer type

Valve characteristics see article 2101.

GNP					
MED.	MOD. ACT	A	E	L	D
2"	GNP-44	337,5	117,5	168	83
2 1/2"	GNP-44	356,5	117,5	168	83
3"	GNP-60	382,5	129,5	184	92
4"	GNP-94	428,5	138,5	204	103
5"	GNP-198	480	163	268	121,5
6"	GNP-300	534	185	296	142
8"	GNP-513	612,5	201,5	390	152

GNP					
MED.	MOD. ACT	A	E	L	D
2"	GNP-94/S5	358,5	138,5	204	103
2 1/2"	GNP-94/S5	377,5	138,5	204	103
3"	GNP-135/S5	400	147	262	108,5
4"	GNP-198/S6	453	163	268	121,5
5"	GNP-513/S5	518,5	201,5	390	152
6"	GNP-800/S5	576	227	454	174
8"	GNP-1280/S5	671	260	525	206

CÓDIGO CODE	MEDIDA SIZE	TIPO ACT. ACT. TYPE	PESO WEIGHT	P.V.P. € PRICE €
----------------	----------------	------------------------	----------------	---------------------

GNP Doble efecto / GNP Double acting				
5111 09 128	2"	GNP-44	6.12	434,23
5111 10 128	2 1/2"	GNP-44	6.38	460,90
5111 11 138	3"	GNP-60	7.54	607,33
5111 12 142	4"	GNP-94	8.56	774,23
5111 13 150	5"	GNP-198	13.57	887,45
5111 14 158	6"	GNP-300	16.24	1217,16
5111 16 162	8"	GNP-513	24.79	1998,56
GNP Simple efecto / GNP Spring return				
5111 09 144	2"	GNP-94/S5	7.62	516,65
5111 10 144	2 1/2"	GNP-94/S5	7.88	543,32
5111 11 148	3"	GNP-135/S5	10.34	698,11
5111 12 156	4"	GNP-198/S6	13.33	903,72
5111 13 164	5"	GNP-513/S5	22.07	1299,69
5111 14 168	6"	GNP-800/S5	30.64	1674,98
5111 16 172	8"	GNP-1280/S5	60.08	2743,09

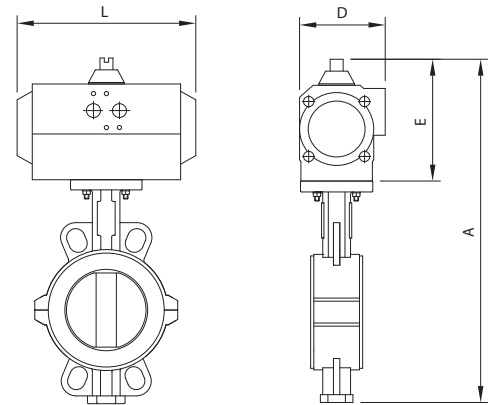

Información técnica
Technical information

Ref.5111T **NEW**



Válvula mariposa tipo wafer

Características de la válvula ver artículo 2101T.

Butterfly valve wafer type

Valve characteristics see article 2101T.

GNP					
MED.	MOD. ACT	A	E	L	D
2"	GNP-44	337,5	117,5	168	83
2 1/2"	GNP-44	356,5	117,5	168	83
3"	GNP-60	382,5	129,5	184	92
4"	GNP-94	428,5	138,5	204	103
5"	GNP-198	480	163	268	121,5
6"	GNP-300	534	185	296	142
8"	GNP-513	612,5	201,5	390	152

GNP					
MED.	MOD. ACT	A	E	L	D
2"	GNP-94/S5	358,5	138,5	204	103
2 1/2"	GNP-94/S5	377,5	138,5	204	103
3"	GNP-135/S5	400	147	262	108,5
4"	GNP-198/S6	453	163	268	121,5
5"	GNP-513/S5	518,5	201,5	390	152
6"	GNP-800/S5	576	227	454	174
8"	GNP-1280/S5	671	260	525	206

GNP Doble efecto / GNP Double acting				
5111T 09 128	2"	GNP-44	6.12	-
5111T 10 128	2 1/2"	GNP-44	6.38	-
5111T 11 138	3"	GNP-60	7.54	-
5111T 12 142	4"	GNP-94	8.56	-
*5111T 13 150	5"	GNP-198	13.57	-
5111T 14 158	6"	GNP-300	16.24	-
5111T 16 162	8"	GNP-513	24.79	-
GNP Simple efecto / GNP Spring return				
5111T 09 144	2"	GNP-94/S5	7.62	-
5111T 10 144	2 1/2"	GNP-94/S5	7.88	-
5111T 11 148	3"	GNP-135/S5	10.34	-
5111T 12 156	4"	GNP-198/S6	13.33	-
5111T 13 164	5"	GNP-513/S5	22.07	-
5111T 14 168	6"	GNP-800/S5	30.64	-
5111T 16 172	8"	GNP-1280/S5	60.08	-

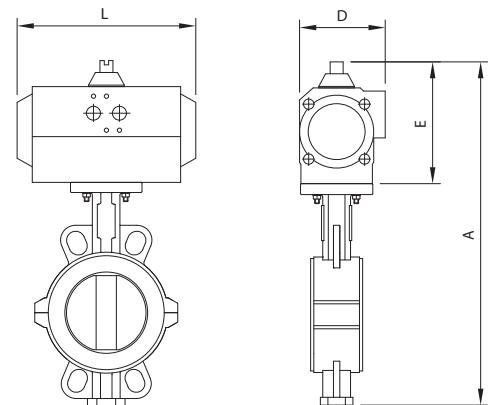

Información técnica
Technical information

Ref.5113

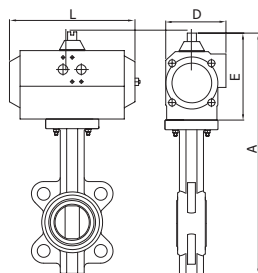

Válvula mariposa tipo wafer

Características de la válvula ver artículo 2103.

Butterfly valve wafer type

Valve characteristics see article 2103.

GN					
MED.	MOD. ACT	A	E	L	D
2"	GN-15	350	111	165	81
2 1/2"	GN-15	364	111	165	81
3"	GN-17	379	111	197	81
4"	GN-20	433	128	177	96
5"	GN-25	470	128	239	96
6"	GN-25	496	128	239	96
8"	GN-35	614	184	246	131
10"	GN-40	695	184	290	131
12"	GN-45	769	198	351	145
14"	GN-60	787	287	420	230
16"	GN-60	857	287	420	230
18"	GN-65	912	287	502	230
20"	GN-70	1061	358	611	338

GN					
MED.	MOD. ACT	A	E	L	D
2"	GN-17/S5	350	111	197	81
2 1/2"	GN-25/S5	381	128	239	96
3"	GN-30/S4	415	147	230	114
4"	GN-30/S5	452	147	230	114
5"	GN-35/S4	527	184	246	131
6"	GN-35/S5	552	184	246	131
8"	GN-45/S4	628	198	351	145
10"	GN-50/S4	743	232	361	181
12"	GN-55/S6	803	232	418	181
14"	GN-70/S5	858	358	611	338
16"	GN-70/S6	928	358	611	338



Información técnica
Technical information

Ref.5113

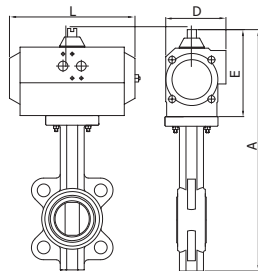

Válvula mariposa tipo wafer

Características de la válvula ver artículo 2103.

Butterfly valve wafer type

Valve characteristics see article 2103.

GNP					
MED.	MOD. ACT	A	E	L	D
2"	GNP-44	356,5	117,5	168	83
2 1/2"	GNP-44	370,5	117,5	168	83
3"	GNP-44	385,5	117,5	168	83
4"	GNP-60	434,5	129,5	184	92
5"	GNP-94	481,5	138,5	204	103
6"	GNP-94	506,5	138,5	204	103
8"	GNP-198	593	163	268	121,5
10"	GNP-300	696	185	296	142
12"	GNP-513	772,5	201,5	390	152
14"	GNP-1280	760	260	525	206
16"	GNP-1280	830	260	525	206
18"	GNP-1600	910	285	532	226
20"	GNP-2300	1021	318	610	260

GNP					
MED.	MOD. ACT	A	E	L	D
2"	GNP-44/S4	356,5	117,5	168	83
2 1/2"	GNP-94/S5	391,5	138,5	204	103
3"	GNP-135/S5	415	147	262	108,5
4"	GNP-135/S5	452	147	262	108,5
5"	GNP-198/S5	506	163	268	121,5
6"	GNP-198/S6	531	163	268	121,5
8"	GNP-513/S5	631,5	201,5	390	152
10"	GNP-800/S5	738	227	454	174
12"	GNP-1280/S5	831	260	525	206
14"	GNP-2500/S5	856	356	722	294
16"	GNP-2500/S5	926	356	722	294
18"	GNP-3000/S6	1035	378	772	406
20"	GNP-3500/S5	1140	410	870	460



Información técnica
Technical information

CÓDIGO CODE	MEDIDA SIZE	TIPO ACT. ACT. TYPE	PESO WEIGHT	P.V.P. € PRICE €
----------------	----------------	------------------------	----------------	---------------------

Gen-Air Doble efecto / Gen-Air Double acting				
5113 09 48	2"	GN-15	4.44	189,54
5113 10 48	2 1/2"	GN-15	5.22	199,79
5113 11 53	3"	GN-17	7.61	211,45
5113 12 64	4"	GN-20	10.03	245,11
5113 13 65	5"	GN-25	13.07	282,51
5113 14 65	6"	GN-25	14.1	283,20
5113 16 67	8"	GN-35	23.48	455,62
5113 18 68	10"	GN-40	31.23	590,27
5113 20 69	12"	GN-45	45.4	876,93
5113 22 57	14"	GN-60	87.5	1448,03
5113 24 54	16"	GN-60	108	2058,52
5113 26 58	18"	GN-65	0.01	2703,36
5113 28 100	20"	GN-70	0.01	4771,55
Gen-Air Simple efecto / Gen-Air Spring return				
5113 09 51	2"	GN-17/S5	5.56	235,18
5113 10 85	2 1/2"	GN-25/S5	9.38	302,52
5113 11 78	3"	GN-30/S4	10.97	319,57
5113 12 86	4"	GN-30/S5	10.88	333,03
5113 13 87	5"	GN-35/S4	16.7	442,15
5113 14 88	6"	GN-35/S5	19.52	475,00
5113 16 81	8"	GN-45/S4	26.92	632,03
5113 18 95	10"	GN-50/S4	41.13	945,88
5113 20 90	12"	GN-55/S6	59.4	1289,75
5113 22 101	14"	GN-70/S5	0.01	3242,86
5113 24 102	16"	GN-70/S6	153.7	4327,96

GNP Doble efecto / GNP Double acting				
5113 09 128	2"	GNP-44	4.544	181,61
5113 10 128	2 1/2"	GNP-44	5.4	189,98
5113 11 128	3"	GNP-44	6.073	195,09
5113 12 138	4"	GNP-60	8	225,37
5113 13 142	5"	GNP-94	10.7	255,08
5113 14 142	6"	GNP-94	11.23	256,42
5113 16 150	8"	GNP-198	21.8	398,22
5113 18 158	10"	GNP-300	28.7	552,22
5113 20 162	12"	GNP-513	40.7	814,26
5113 22 171	14"	GNP-1280	75.45	1349,51
5113 24 170	16"	GNP-1280	92.85	1863,31
5113 26 174	18"	GNP-1600	0.01	2423,48
5113 28 176	20"	GNP-2300	0.01	4260,40
GNP Simple efecto / GNP Spring return				
5113 09 132	2"	GNP-44/S4	4.65	209,67
5113 10 144	2 1/2"	GNP-94/S5	6.9	272,40
5113 11 148	3"	GNP-135/S5	9.3	296,09
5113 12 148	4"	GNP-135/S5	11.5	308,56
5113 13 154	5"	GNP-198/S5	13.426	386,46
5113 14 156	6"	GNP-198/S6	15.7	415,15
5113 16 164	8"	GNP-513/S5	28.468	643,32
5113 18 168	10"	GNP-800/S5	44.5	943,74
5113 20 172	12"	GNP-1280/S5	63.105	1377,25
5113 22 180	14"	GNP-2500/S5	144.55	3589,21
5113 24 180	16"	GNP-2500/S5	117.5	4103,00
5113 26 185	18"	GNP-3000/S6	267	6268,03
5113 28 190	20"	GNP-3500/S5	0.001	-

Ref.5119

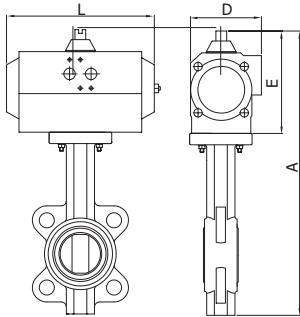

Válvula mariposa tipo wafer

Características de la válvula ver artículo 2109.

Butterfly valve wafer type

Valve characteristics see article 2109.

GN					
MED.	MOD. ACT	A	E	L	D
2"	GN-15	350	111	165	81
2 1/2"	GN-15	364	111	165	81
3"	GN-17	379	111	197	81
4"	GN-20	433	128	177	96
5"	GN-25	470	128	239	96
6"	GN-25	496	128	239	96
8"	GN-35	614	184	246	131
10"	GN-40	695	184	290	131
12"	GN-45	769	198	351	145
14"	GN-60	787	287	420	230
16"	GN-60	857	287	420	230
18"	GN-65	912	287	502	230
20"	GN-70	1061	358	611	338

GN					
MED.	MOD. ACT	A	E	L	D
2"	GN-17/S5	350	111	197	81
2 1/2"	GN-25/S5	381	128	239	96
3"	GN-30/S4	415	147	230	114
4"	GN-30/S5	452	147	230	114
5"	GN-35/S4	527	184	246	131
6"	GN-35/S5	552	184	246	131
8"	GN-45/S4	628	198	351	145
10"	GN-50/S4	743	232	361	181
12"	GN-55/S6	803	232	418	181
14"	GN-70/S5	858	358	611	338
16"	GN-70/S6	928	358	611	338



Información técnica
Technical information

Ref.5119

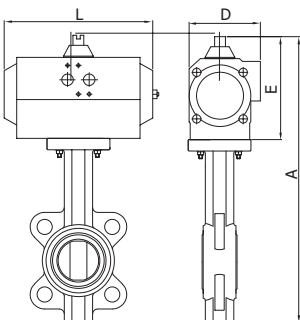

Válvula mariposa tipo wafer

Características de la válvula ver artículo 2109.

Butterfly valve wafer type

Valve characteristics see article 2109.

GNP					
MED.	MOD. ACT	A	E	L	D
2"	GNP-44	356,5	117,5	168	83
2 1/2"	GNP-44	370,5	117,5	168	83
3"	GNP-44	385,5	117,5	168	83
4"	GNP-60	434,5	129,5	184	92
5"	GNP-94	481,5	138,5	204	103
6"	GNP-94	506,5	138,5	204	103
8"	GNP-198	593	163	268	121,5
10"	GNP-300	696	185	296	142
12"	GNP-513	772,5	201,5	390	152
14"	GNP-1280	760	260	260	206
16"	GNP-1280	830	260	525	206
18"	GNP-1600	910	285	532	226
20"	GNP-2300	1021	318	610	260

GNP					
MED.	MOD. ACT	A	E	L	D
2"	GNP-44/S4	356,5	117,5	168	83
2 1/2"	GNP-94/S5	391,5	138,5	204	103
3"	GNP-135/S5	415	147	262	108,5
4"	GNP-135/S5	452	147	262	108,5
5"	GNP-198/S5	506	163	268	121,5
6"	GNP-198/S6	531	163	268	121,5
8"	GNP-513/S5	631,5	201,5	390	152
10"	GNP-800/S5	738	227	454	174
12"	GNP-1280/S5	831	260	525	206
14"	GNP-2500/S5	856	356	722	294
16"	GNP-2500/S5	926	356	722	294
18"	GNP-3000/S6	1035	378	772	406
20"	GNP-3500/S5	1140	410	870	460



Información técnica
Technical information

CÓDIGO CODE	MEDIDA SIZE	TIPO ACT. ACT. TYPE	PESO WEIGHT	P.V.P. € PRICE €
----------------	----------------	------------------------	----------------	---------------------

Gen-Air Doble efecto / Gen-Air Double acting				
5119 09 48	2"	GN-15	4.4	199,65
5119 10 48	2 1/2"	GN-15	5.1	211,18
5119 11 53	3"	GN-17	6.29	226,69
5119 12 64	4"	GN-20	8.4	276,61
5119 13 65	5"	GN-25	10.84	323,26
5119 14 65	6"	GN-25	11.64	339,30
5119 16 67	8"	GN-35	23.48	584,11
5119 18 68	10"	GN-40	31.23	683,72
5119 20 69	12"	GN-45	45.4	1082,17
5119 22 57	14"	GN-60	87.5	1865,04
5119 24 54	16"	GN-60	108	2569,47
5119 26 58	18"	GN-65	164	3399,73
5119 28 100	20"	GN-70	219	5851,47
Gen-Air Simple efecto / Gen-Air Spring return				
5119 09 51	2"	GN-17/S5	5.56	241,08
5119 10 85	2 1/2"	GN-25/S5	7.12	314,59
5119 11 78	3"	GN-30/S4	9.86	335,74
5119 12 86	4"	GN-30/S5	10.72	364,53
5119 13 87	5"	GN-35/S4	16	482,91
5119 14 88	6"	GN-35/S5	19.52	531,10
5119 16 81	8"	GN-45/S4	29.4	760,51
5119 18 95	10"	GN-50/S4	41.13	1117,99
5119 20 90	12"	GN-55/S6	59.4	1494,99
5119 22 101	14"	GN-70/S5	0.01	4483,16
5119 24 102	16"	GN-70/S6	153.7	5536,00

GNP Doble efecto / GNP Double acting				
5119 09 128	2"	GNP-44	4.9	188,03
5119 10 128	2 1/2"	GNP-44	5.4	199,25
5119 11 128	3"	GNP-44	6.54	211,80
5119 12 138	4"	GNP-60	9.12	253,85
5119 13 142	5"	GNP-94	10.5	295,35
5119 14 142	6"	GNP-94	13.4	310,24
5119 16 150	8"	GNP-198	23.24	536,04
5119 18 158	10"	GNP-300	30.2	633,44
5119 20 162	12"	GNP-513	41.07	1002,60
5119 22 171	14"	GNP-1280	74.25	1759,80
5119 24 170	16"	GNP-1280	93.275	2348,20
5119 26 174	18"	GNP-1600	124.1	3068,64
5119 28 176	20"	GNP-2300	165.85	5260,91
GNP Simple efecto / GNP Spring return				
5119 09 132	2"	GNP-44/S4	5.17	218,55
5119 10 144	2 1/2"	GNP-94/S5	6.9	288,16
5119 11 148	3"	GNP-135/S5	8.5	308,12
5119 12 148	4"	GNP-135/S5	10.25	334,54
5119 13 154	5"	GNP-198/S5	14.38	443,17
5119 14 156	6"	GNP-198/S6	15.25	487,39
5119 16 164	8"	GNP-513/S5	28.8	750,70
5119 18 168	10"	GNP-800/S5	44.5	1017,33
5119 20 172	12"	GNP-1280/S5	83.6	1545,46
5119 22 180	14"	GNP-2500/S5	143.35	3917,00
5119 24 180	16"	GNP-2500/S5	163.82	4486,80
5119 26 185	18"	GNP-3000/S6	267	-
5119 28 190	20"	GNP-3500/S5	395	10519,98

Válvula con elastómetro NBR (5119B), Precios a consultar. /
NBR elastomer valve (5119B), Prices on request.

Ref.5114



Válvula mariposa tipo wafer inoxidable
Características de la válvula ver artículo 2104.

Stainless steel butterfly valve wafer type
Valve characteristics see article 2104.

GN					
MED.	MOD. ACT	A	E	L	D
2"	GN-15	321	111	165	81
2 1/2"	GN-17	331	111	197	81
3"	GN-20	356	128	177	96
4"	GN-25	402	128	239	96
5"	GN-35	490	184	246	131
6"	GN-40	519	184	290	131
8"	GN-50	641	232	361	181
10"	GN-55	706	232	428	181

GN					
MED.	MOD. ACT	A	E	L	D
2"	GN-25/S4	338	128	239	96
2 1/2"	GN-25/S5	348	128	239	96
3"	GN-30/S4	375	147	230	114
4"	GN-35/S5	458	184	246	131
5"	GN-45/S5	504	198	351	145
6"	GN-50/S5	567	232	361	181
8"	GN-55/S5	698	287	418	181

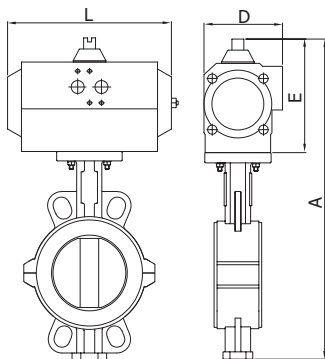

CÓDIGO CODE	MEDIDA SIZE	TIPO ACT. ACT. TYPE	PESO WEIGHT	P.V.P. € PRICE €
----------------	----------------	------------------------	----------------	---------------------

Gen-Air Doble efecto / Gen-Air Double acting				
5114 09 63	2"	GN-15	5.63	627,12
5114 10 52	2 1/2"	GN-17	6.57	734,35
5114 11 64	3"	GN-20	7.77	903,27
5114 12 65	4"	GN-25	10.5	1134,88
5114 13 67	5"	GN-35	15.78	1446,38
5114 14 68	6"	GN-40	18.63	1771,00
5114 16 97	8"	GN-50	32.5	3083,45
5114 18 84	10"	GN-55	47.1	4191,59
Gen-Air Simple efecto / Gen-Air Spring return				
5114 09 77	2"	GN-25/S4	8.28	732,11
5114 10 85	2 1/2"	GN-25/S5	8.88	844,62
5114 11 78	3"	GN-30/S4	10.47	985,27
5114 12 88	4"	GN-35/S5	15.52	1304,64
5114 13 89	5"	GN-45/S5	23.22	1635,00
5114 14 98	6"	GN-50/S5	32.23	2176,75
5114 16 99	8"	GN-55/S5	60.6	3693,06



Información técnica
Technical information

Ref.5114



Válvula mariposa tipo wafer inoxidable
Características de la válvula ver artículo 2104.

Stainless steel butterfly valve wafer type
Valve characteristics see article 2104.

GNP					
MED.	MOD. ACT	A	E	L	D
2"	GNP-44	327,5	117,5	168	83
2 1/2"	GNP-44	337,5	117,5	168	83
3"	GNP-60	357,5	129,5	184	92
4"	GNP-94	412,5	138,5	204	103
5"	GNP-198	469	163	268	121,5
6"	GNP-300	520	185	296	142
8"	GNP-513	610,5	201,5	390	152
10"	GNP-800	701,0	227,0	454	174

GNP					
MED.	MOD. ACT	A	E	L	D
2"	GNP-94/S5	348,5	138,5	204	103
2 1/2"	GNP-94/S5	358,5	138,5	204	103
3"	GNP-135/S5	375	147	262	108,5
4"	GNP-198/S6	437	163	268	121,5
5"	GNP-513/S5	507,5	201,5	390	152
6"	GNP-800/S5	562	227	454	174
8"	GNP-1280/S5	669	260	525	206

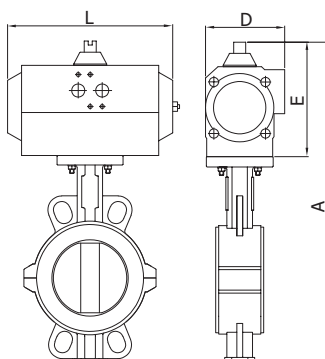

GNP Doble efecto / GNP Double acting				
5114 09 128	2"	GNP-44	4.5	552,16
5114 10 128	2 1/2"	GNP-44	5.05	665,73
5114 11 138	3"	GNP-60	6.63	804,15
5114 12 142	4"	GNP-94	9.8	1004,48
5114 13 150	5"	GNP-198	14.1	1276,38
5114 14 158	6"	GNP-300	18.6	1590,24
5114 16 162	8"	GNP-513	26.7	2721,90
5114 18 166	10"	GNP-800	45.2	3765,15
GNP Simple efecto / GNP Spring return				
5114 09 144	2"	GNP-94/S5	6.5	656,99
5114 10 144	2 1/2"	GNP-94/S5	6.9	748,15
5114 11 148	3"	GNP-135/S5	10.4	894,92
5114 12 156	4"	GNP-198/S6	13.2	1146,77
5114 13 164	5"	GNP-513/S5	22.6	1519,96
5114 14 168	6"	GNP-800/S5	32.9	2020,38
5114 16 172	8"	GNP-1280/S5	60.8	3391,58



Información técnica
Technical information

Ref.5508

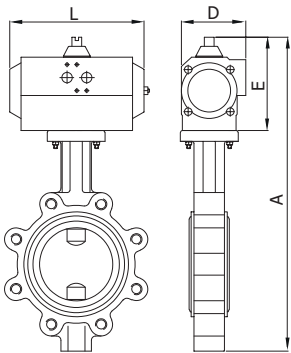
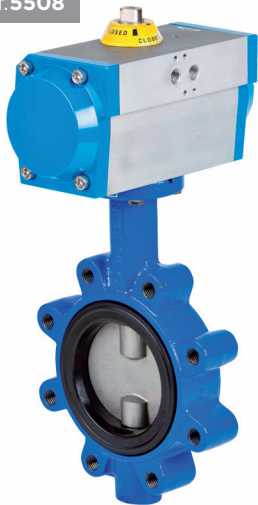

Válvula mariposa tipo LUG (bridas DIN)
Características de la válvula ver artículo 2108.

Butterfly valve LUG type (DIN flanges)
Valve characteristics see article 2108.

GN					
MED.	MOD. ACT	A	E	L	D
2"	GN-15	351	111	165	81
2 1/2"	GN-15	364	111	165	81
3"	GN-17	379	111	197	81
4"	GN-20	433	128	177	96
5"	GN-25	471	128	239	96
6"	GN-25	496	128	239	96
8"	GN-35	614	184	246	131
10"	GN-40	695	184	290	131
12"	GN-45	770	198	351	145

GN					
MED.	MOD. ACT	A	E	L	D
2"	GN-17/S5	351	111	197	81
2 1/2"	GN-25/S5	381	128	239	96
3"	GN-30/S4	415	147	230	114
4"	GN-30/S5	452	147	230	114
5"	GN-35/S4	527	184	246	131
6"	GN-35/S5	552	184	246	131
8"	GN-45/S4	628	198	351	145
10"	GN-50/S4	743	232	361	181
12"	GN-55/S6	804	232	418	181



Información técnica
Technical information

Ref.5508

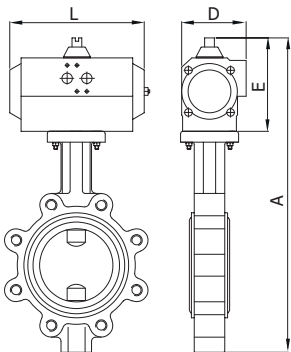

Válvula mariposa tipo LUG (bridas DIN)
Características de la válvula ver artículo 2108.

Butterfly valve LUG type (DIN flanges)
Valve characteristics see article 2108.

GNP					
MED.	MOD. ACT	A	E	L	D
2"	GNP-44	357,5	117,5	168	83
2 1/2"	GNP-44	370,5	117,5	168	83
3"	GNP-44	385,5	117,5	168	83
4"	GNP-60	434,5	129,5	184	92
5"	GNP-94	481,5	138,5	204	103
6"	GNP-94	506,5	138,5	204	103
8"	GNP-198	593	163	268	121,5
10"	GNP-300	696	185	296	142
12"	GNP-513	773,5	201,5	390	152

GNP					
MED.	MOD. ACT	A	E	L	D
2"	GNP-44/S4	357,5	117,5	168	83
2 1/2"	GNP-94/S5	391,5	138,5	204	103
3"	GNP-135/S5	415	147	262	108,5
4"	GNP-135/S5	452	147	262	108,5
5"	GNP-198/S5	506	163	268	121,5
6"	GNP-198/S6	531	163	268	121,5
8"	GNP-513/S5	631,5	201,5	390	152
10"	GNP-800/S5	738	227	454	174
12"	GNP-1280/S5	832	260	525	206



Información técnica
Technical information

CÓDIGO CODE	MEDIDA SIZE	TIPO ACT. ACT. TYPE	PESO WEIGHT	P.V.P. € PRICE €
----------------	----------------	------------------------	----------------	---------------------

Gen-Air Doble efecto / Gen-Air Double acting				
5508 09 48	2"	GN-15	6.63	205,48
5508 10 48	2 1/2"	GN-15	7.33	218,00
5508 11 53	3"	GN-17	8.405	232,63
5508 12 64	4"	GN-20	11.83	292,35
5508 13 65	5"	GN-25	15.17	355,24
5508 14 65	6"	GN-25	14.5	374,60
5508 16 67	8"	GN-35	25.78	606,71
5508 18 68	10"	GN-40	37.33	812,11
5508 20 69	12"	GN-45	56.9	1069,68
Gen-Air Simple efecto / Gen-Air Spring return				
5508 09 51	2"	GN-17/S5	5.8	246,64
5508 10 85	2 1/2"	GN-25/S5	9.98	321,82
5508 11 78	3"	GN-30/S4	11.37	342,04
5508 12 86	4"	GN-30/S5	14.67	381,67
5508 13 87	5"	GN-35/S4	18.8	518,09
5508 14 88	6"	GN-35/S5	22.72	578,57
5508 16 81	8"	GN-45/S4	29.22	807,83
5508 18 95	10"	GN-50/S4	47.23	1176,10
5508 20 90	12"	GN-55/S6	70.9	1515,44

Válvula con elastómetro NBR (5508B), Precios a consultar /
NBR elastomer valve (5508B), Prices on request.

GNP Doble efecto / GNP Double acting				
5508 09 128	2"	GNP-44	6.9	188,38
5508 10 128	2 1/2"	GNP-44	7.6	199,41
5508 11 128	3"	GNP-44	7.76	221,18
5508 12 138	4"	GNP-60	11.66	262,80
5508 13 142	5"	GNP-94	14.47	319,96
5508 14 142	6"	GNP-94	16.6	337,41
5508 16 150	8"	GNP-198	24.1	509,43
5508 18 158	10"	GNP-300	37.3	717,96
5508 20 162	12"	GNP-513	56.44	945,66
GNP Simple efecto / GNP Spring return				
5508 09 132	2"	GNP-44/S4	6.49	226,38
5508 10 144	2 1/2"	GNP-94/S5	9.4	288,77
5508 11 148	3"	GNP-135/S5	12.8	329,38
5508 12 148	4"	GNP-135/S5	14.6	356,24
5508 13 154	5"	GNP-198/S5	16.48	449,42
5508 14 156	6"	GNP-198/S6	20.4	503,07
5508 16 164	8"	GNP-513/S5	28.6	805,83
5508 18 168	10"	GNP-800/S5	47.9	1146,51
5508 20 172	12"	GNP-1280/S5	90	1684,97

Válvula con elastómetro NBR (5508B), Precios a consultar /
NBR elastomer valve (5508B), Prices on request.

Ref.5508A

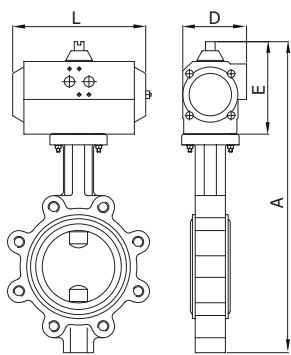

Válvula mariposa tipo LUG (bridas ANSI)

Características de la válvula ver artículo 2108A.

Butterfly valve LUG type (ANSI flanges)

Valve characteristics see article 2108A.

GN					
MED.	MOD. ACT	A	E	L	D
2"	GN-15	351	111	165	81
2 1/2"	GN-15	364	111	165	81
3"	GN-17	379	111	197	81
4"	GN-20	433	128	177	96
5"	GN-25	471	128	239	96
6"	GN-25	496	128	239	96
8"	GN-35	614	184	246	131
10"	GN-40	695	184	290	131
12"	GN-45	770	198	351	145
14"	GN-60	865	287	420	230
16"	GN-60	933	287	420	230
18"	GN-65	990	287	502	230
20"	GN-70	1126	358	611	338

GN					
MED.	MOD. ACT	A	E	L	D
2"	GN-17/S5	351	111	197	81
2 1/2"	GN-25/S5	381	128	239	96
3"	GN-30/S4	415	147	230	114
4"	GN-30/S5	452	147	230	114
5"	GN-35/S4	527	184	246	131
6"	GN-35/S5	552	184	246	131
8"	GN-45/S4	628	198	351	145
10"	GN-50/S4	743	232	361	181
12"	GN-55/S6	804	232	418	181
14"	GN-70/S5	936	358	611	338
16"	GN-70/S6	1004	358	611	338



Información técnica
Technical information

Ref.5508A

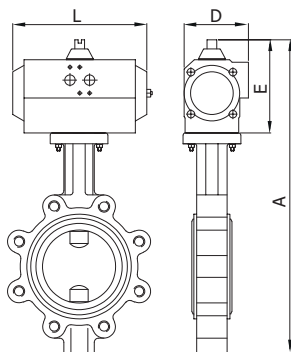

Válvula mariposa tipo LUG (bridas ANSI)

Características de la válvula ver artículo 2108A.

Butterfly valve LUG type (ANSI flanges)

Valve characteristics see article 2108A.

GNP					
MED.	MOD. ACT	A	E	L	D
2"	GNP-44	357,5	117,5	168	83
2 1/2"	GNP-44	370,5	117,5	168	83
3"	GNP-44	385,5	117,5	168	83
4"	GNP-60	434,5	129,5	184	92
5"	GNP-94	481,5	138,5	204	103
6"	GNP-94	506,5	138,5	204	103
8"	GNP-198	593	163	268	121,5
10"	GNP-300	696	185	296	142
12"	GNP-513	773,5	201,5	390	152
14"	GNP-1280	838	260	525	206
16"	GNP-1280	906	260	525	206
18"	GNP-1600	988	285	532	226
20"	GNP-2300	1086	318	610	260

GNP					
MED.	MOD. ACT	A	E	L	D
2"	GNP-44/S4	357,5	117,5	168	83
2 1/2"	GNP-94/S5	391,5	138,5	204	103
3"	GNP-135/S5	415	147	262	108,5
4"	GNP-135/S5	452	147	262	108,5
5"	GNP-198/S5	506	163	268	121,5
6"	GNP-198/S6	531	163	268	121,5
8"	GNP-513/S5	631,5	201,5	390	152
10"	GNP-800/S5	738	227	454	174
12"	GNP-1280/S5	831	260	525	206
14"	GNP-2500/S5	934	356	722	294
16"	GNP-2500/S5	1002	356	722	294



Información técnica
Technical information

CÓDIGO CODE	MEDIDA SIZE	TIPO ACT. ACT. TYPE	PESO WEIGHT	P.V.P. € PRICE €
----------------	----------------	------------------------	----------------	---------------------

Gen-Air Doble efecto / Gen-Air Double acting				
5508A 09 48	2"	GN-15	6.63	205,04
5508A 10 48	2 1/2"	GN-15	1	-
5508A 11 53	3"	GN-17	6.63	240,71
5508A 12 64	4"	GN-20	11.83	291,78
5508A 13 65	5"	GN-25	15.17	355,24
5508A 14 65	6"	GN-25	17.3	374,60
5508A 16 67	8"	GN-35	25.78	605,96
5508A 18 68	10"	GN-40	37.5	797,08
5508A 20 69	12"	GN-45	56.9	1148,41
5508A 22 57	14"	GN-60	99	2416,04
5508A 24 54	16"	GN-60	1	-
5508A 26 58	18"	GN-65	1	-
5508A 28 100	20"	GN-70	247.5	6227,02
Gen-Air Simple efecto / Gen-Air Spring return				
5508A 09 51	2"	GN-17/S5	5.96	247,53
5508A 10 85	2 1/2"	GN-25/S5	9.98	322,92
5508A 11 78	3"	GN-30/S4	11.37	343,28
5508A 12 86	4"	GN-30/S5	14.67	385,10
5508A 13 87	5"	GN-35/S4	17	540,67
5508A 14 88	6"	GN-35/S5	22.72	555,55
5508A 16 81	8"	GN-45/S4	29.22	809,07
5508A 18 95	10"	GN-50/S4	47.23	1166,81
5508A 20 90	12"	GN-55/S6	70.9	1601,21
5508A 22 101	14"	GN-70/S5	1	-
5508A 24 102	16"	GN-70/S6	173.1	5147,77

Válvula con elastómetro NBR (5508AB), Precios a consultar /
NBR elastomer valve (5508AB), Prices on request.

GNP Doble efecto / GNP Double acting				
5508A 09 128	2"	GNP-44	6.9	190,22
5508A 10 128	2 1/2"	GNP-44	7.76	200,13
5508A 11 128	3"	GNP-44	7.76	220,66
5508A 12 138	4"	GNP-60	9.92	262,21
5508A 13 142	5"	GNP-94	14.47	319,24
5508A 14 142	6"	GNP-94	15	336,65
5508A 16 150	8"	GNP-198	22.1	544,57
5508A 18 158	10"	GNP-300	47.9	716,33
5508A 20 162	12"	GNP-513	56.44	1013,30
5508A 22 170	14"	GNP-1280	101.8	2174,44
5508A 24 170	16"	GNP-1280	130.2	2758,59
5508A 26 174	18"	GNP-1600	189.8	3572,91
5508A 28 176	20"	GNP-2300	239.7	5604,32
GNP Simple efecto / GNP Spring return				
5508A 09 132	2"	GNP-44/S4	5.57	220,85
5508A 10 144	2 1/2"	GNP-94/S5	9.4	291,70
5508A 11 148	3"	GNP-135/S5	11.3	320,93
5508A 12 148	4"	GNP-135/S5	11.66	343,58
5508A 13 154	5"	GNP-198/S5	16.48	457,15
5508A 14 156	6"	GNP-198/S6	20.4	487,10
5508A 16 164	8"	GNP-513/S5	28.6	807,51
5508A 18 168	10"	GNP-800/S5	47.9	1128,38
5508A 20 172	12"	GNP-1280/S5	1	1700,30
5508A 22 180	14"	GNP-2500/S5	177.6	4260,37
5508A 24 180	16"	GNP-2500/S5	206	4763,35

Válvula con elastómetro NBR (5508AB), Precios a consultar /
NBR elastomer valve (5508AB), Prices on request.

Ref.4519

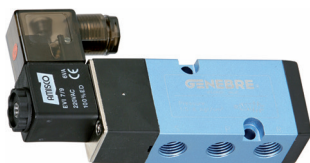

Electrovalvula 5 vías

Acoplamiento conforme con la norma Namur 5 vías / 2 posiciones. Dispositivo de mando manual. Consumo 5 W. Grado de protección: IP 65 con conector y juntas. Racores: 1/4" gas. Presión de trabajo: min. 2 bar máx. 10 bar. Límite de temperaturas: -5°C +60°C.

5-ways solenoid valve

Coupling according norm Namur functioning 5 ways / 2 positions. Manual control device. Consumption 5 W. Protection: IP 65 with connector and seals. Connectors: 1/4" gas. Working pressure: min. 2 bar max. 10 bar. Temperature limits: -5°C +60°C.

CÓDIGO CODE	MEDIDA SIZE	PESO WEIGHT	P.V.P. € PRICE €
4519 02 A12V	A12V	0.44	49,63
4519 02 C12V	C12V	0.64	49,63
4519 02 A24V	A24V	0.305	49,63
4519 02 C24V	C24V	0.31	49,63
4519 02 A48V	A48V	0.311	49,63
4519 02 C48V	C48V	0.31	49,63
4519 02 110V	110V	0.306	49,63
4519 02 220V	220V	0.306	49,63



Información técnica
Technical information

Ref.4521



Electrovalvula 5 vías con bobina de seguridad

Intrínseca = ATEX Ex 2G EEx ia IIC T6.

5-ways solenoid valve with intrinsic safety coil

ATEX Ex 2G EEx ia IIC T6.

4521 02 C24V	-	0.364	273,97
--------------	---	-------	--------



Información técnica
Technical information

Ref.4522



Electrovalvula 5 vías con bobina antideflagrante

ATEX Ex 2G EEx m II T4.

5 ways solenoid valve with protection by encapsulation coil

ATEX Ex 2G EEx m II T4.

4522 02 C24V	-	0.48	273,97
4522 02 220V	-	0.67	273,97



Información técnica
Technical information

Ref.4523



Electrovalvula 5 vías biestable

Acoplamiento conforme con la norma Namur.

5 ways solenoid valve dual stable

Coupling according NAMUR std.

4523 02 C24V	C24V	0.424	102,60
4523 02 220V	220V	0.408	102,60



Información técnica
Technical information

Ref.4819

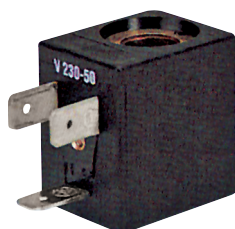

Bobina para electrovalvulas 5 vías

Potencia 5W. Tolerancia de tensión en corriente alterna (+10% - 15%) y en corriente continua (+10% - 5%). Voltajes disponibles en corriente alterna 24V - 48V - 110V - 220V (50-60 Hz) y en corriente continua 12V - 24V. Clase F. Temperatura máxima 155°C. Grado de protección IP65.

5 Ways solenoid valve coil

5W power. Voltage tolerance in alternating current (10% - 15%) and in direct current (+10% - 5%). Available voltages in alternating current 24V - 48V - 110V - 220V (50-60 Hz) and in direct current 12V - 24V. F class. Maxim Temperature 155°C. IP65 degree protection.

4819 A12V	-	0.087	6,72
4819 C12V	-	0.062	6,72
4819 A24V	-	0.056	6,72
4819 C24V	-	0.06	6,72
4819 A48V	-	0.057	6,72
4819 110V	-	0.057	6,72
4819 220V	-	0.057	6,72

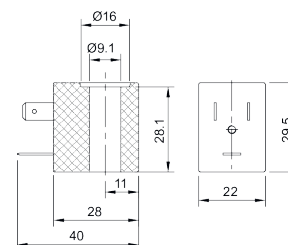

Información técnica
Technical information

CÓDIGO CODE	MEDIDA SIZE	PESO WEIGHT	P.V.P. € PRICE €
----------------	----------------	----------------	---------------------

Ref.4821



Bobina para electroválvula 5 vías
Seguridad Intrínseca: AtexEExia IIC T6

5 waysolenoid valve coil
Intrinsic safety: AtexEExia IIC T6

4821 C24V	-	0.182	144,39
-----------	---	-------	--------



 **Información técnica**
Technical information

Ref.4822



Bobina para electroválvula 5 vías
Antideflagrante: AtexEEx m II T4

5 way solenoid valve coil
Encapsulation coil: AtexEEx m II T4

4822 C24V	-	0.287	210,01
-----------	---	-------	--------

4822 220V	-	0.287	210,01
-----------	---	-------	--------



 **Información técnica**
Technical information

Ref.4801



Conector tripolar de 5W (4801 05) y de 8W (4801 08)

Conector de 3 polos. Potencia 5W. DIN 43650. Grado de protección IP65. Multitensión, para corriente alterna y continua.

3-Pole connector 5W (4801 05) and 8W (4801 08)

3-Pole connector. 5W power. DIN 43650. IP65 degree protection. Multi tension, for AC and DC voltages.

4801 05	-	0.02	2,86
---------	---	------	------



 **Información técnica**
Technical information

Ref.4800



Conector tripolar 5 W con cable
DIN 43650 IP65.

3-Pole 5 W connector with wires
DIN 43650 IP65.

4800 05	-	0.1	18,04
---------	---	-----	-------



 **Información técnica**
Technical information

CÓDIGO CODE	MEDIDA SIZE	PESO WEIGHT	P.V.P. € PRICE €
----------------	----------------	----------------	---------------------

Ref.5950 - 5951



Posicionador rotativo - Neumático

Señal 3 - 15 PSI

Rotary positioner - Pneumatic

Signal 3 - 15 PSI.

5950 00	-	2.7	560,65
---------	---	-----	--------

Actuador no incluido. / Actuator not included.

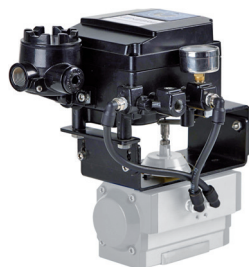

Posicionador rotativo - Electroneumático

Señal 4-20 mA.

Positioners rotary - Electropneumatic

Signal 4-20 mA.

5951 00	-	3.368	734,11
---------	---	-------	--------

Actuador no incluido / Actuator not included.

Posicionador rotativo - Electroneumático

Señal 4-20 mA con retransmisor de posición

Positioners rotary - Electropneumatic

Signal 4-20 mA with position transmitter

5951 04	-	3.706	1009,77
---------	---	-------	---------

Actuador no incluido. / Actuator not included.

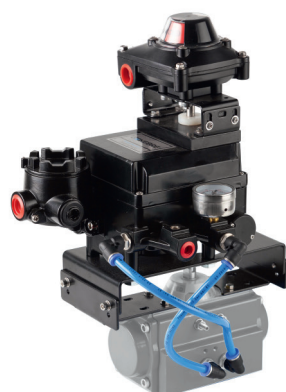

Posicionador rotativo - Electroneumático

Señal 4-20 mA con final de carrera

Positioners rotary - Electropneumatic

Signal 4-20 mA with limit switch

5951 06	-	4.05	782,63
---------	---	------	--------

Actuador y final de carrera no incluido. / Actuator and limit switch not included.



Información técnica
Technical information

Ref.5952



Posicionador lineal - Electroneumático

Señal 4-20 mA.

Lineal positioner - Electropneumatic

Signal 4-20 mA.

5952 00	-	2.879	734,11
---------	---	-------	--------

Válvula no incluida. / Valve not included.

Posicionador lineal - Neumático

Señal 3-15 PSI

Lineal positioner - Pneumatic

Signal 3-15 PSI

5952 02	-	2.65	560,65
---------	---	------	--------

Válvula no incluida. / Valve not included.

Posicionador lineal - Electroneumático

Señal 4 - 20 mA con retransmisor de posición

Lineal positioner - Electropneumatic

Signal 4 - 20 mA with position transmitter

5952 04	-	3.191	1009,77
---------	---	-------	---------

Válvula no incluida. / Valve not included.



Información técnica
Technical information

CÓDIGO CODE	MEDIDA SIZE	PESO WEIGHT	P.V.P. € PRICE €
----------------	----------------	----------------	---------------------

Ref.5953



Controlador de velocidad para actuadores neumáticos
Montaje directo entre actuador y electroválvula NAMUR 5/2.

Pneumatic actuator speed controller
Directly mounts between the actuator and NAMUR solenoid valve 5/2.

5953 02	-	0.2	49,35
---------	---	-----	-------



Información técnica
Technical information

Ref.P5953



Placa adaptadora para controlador de velocidad de actuadores neumáticos

Montaje directo sobre actuador conexión NAMUR.

Adaptor plate for pneumatic actuator speed controller
Directly mounts on actuator NAMUR connection.

P5953	-	0.07	18,19
-------	---	------	-------



Información técnica
Technical information

Ref.5971



Reductor manual de emergencia
Gear box for emergency control

5971 04	200 Nm	5.42	262,11
5971 05	600 Nm	15.105	516,32
5971 06	900 Nm	15.8	619,62

Válvula y actuador no incluido. / Valve and actuator not included.



Información técnica
Technical information

Ref. 5975 - 5976 - 5977 - 5977A - 5977B - 5978 - 5978A



Reductores manuales
Tipo sin fin corona. Cuerpo de fundición.
Gear operators
Worm gear type. Cast iron body.

REDUCTOR MANUAL 2000 Nm F14 C.36

GEAR OPERATOR 2000 NM F14 C.36

Ref.	Torque	S x S	T	U	K	R
5975	300 Nm	17 x 17	F 07	F 05	M8	M6
5976	750 Nm	22 x 22	F 10	F 07	M10	M8
5977	1200 Nm	22 x 22	F 10	---	M10	---
5977A	1200 Nm	22 x 22	F 12	---	M12	---
5977B	1200 Nm	27 x 27	F 14	---	M16	---
5978	2000 Nm	27 x 27	F14	---	M16	---
5978A	2000 Nm	36 x 36	F 14	---	M16	---

5975	300 Nm	4.997	58,15
5976	750 Nm	9.99	97,91
5977	1200 Nm	12.219	114,18
5977A	1200 Nm	12.45	119,37
5977B	1200 Nm	12.15	114,18
5978	2000 Nm	33.527	310,23
5978A	2000 Nm	33.3	310,23



Información técnica
Technical information

Ref.5984



Reductores manuales
Tipo sin fin corona. Cuerpo de aluminio.
Gear operators
Worm gear type. Cast aluminium body.

5984 04	150 Nm	1.381	62,79
5984 05	250 Nm	2.207	95,49
5984 06	750 Nm	5.417	143,24



Información técnica
Technical information

Ref.5985



Mando manual con retorno por muelle

Manual device with spring return

Ref.	Torque	S x S	F
5985 02	11 Nm	11 x 11	F03/F05
5985 07	21 Nm	14 x 14	F03/F05/F07
5985 09	40 Nm	17 x 17	F05/F07

CÓDIGO CODE	MEDIDA SIZE	PESO WEIGHT	P.V.P. € PRICE €
5985 02	11 Nm	1.688	680,67
5985 07	21 Nm	2.383	907,56
5985 09	40 Nm	5.17	1573,44

Válvula no incluida / Valve not included



Información técnica
Technical information

Ref.5987



Microrruptores final de carrera Electromecánico

Limit switch box Electromechanical

Microrruptores final de carrera

2 sensores inductivos ALPS 10-30VCC 2 hilos.
En caja de aluminio norma NAMUR - IP 67.

Limit switch box

2 inductive sensors ALPS 10-30VCC 2 wire. In aluminium "NAMUR" box - IP 67.

Microrruptores final de carrera

2 Sensores inductivos ALPS 10-30VDC 3 hilos "PNP".
En caja de aluminio norma NAMUR - IP 67.

Limit switch box

2 inductive sensors ALPS 10-30VDC 3 wire PNP.
In aluminium "NAMUR" box - IP 67.

Microrruptores final de carrera

2 sensores inductivos NCB2-V3-N0 "P + F" (ATEX EEX ia II C T6. 8V).
En caja de aluminio norma NAMUR - IP 66.

Limit switch box

2 inductive sensors NCB2-V3-N0 "P + F" (ATEX EEX ia II C T6. 8V).
In aluminium "NAMUR" box - IP 66.

5987 02	-	0.587	61,55
---------	---	-------	--------------

Actuador no incluido. / Actuator not included.

5987 04	-	0.616	168,67
---------	---	-------	---------------

Actuador no incluido. / Actuator not included.

5987 06	-	0.621	202,41
---------	---	-------	---------------

Actuador no incluido. / Actuator not included.

5987 08	-	0.589	280,13
---------	---	-------	---------------

Actuador no incluido. / Actuator not included.



Ref.5987



Microrruptores final de carrera Electromecánico CROUZET (125-250VAC)

En caja de aluminio ATEX Ex d II B T6- NAMUR IP67.

Limit switch box Electromechanical CROUZET (125-250VAC)

In aluminium ATEX Ex d II B T6 - NAMUR IP67.

Microrruptores final de carrera

2 sensores inductivos NCB2-V3-N0 "P+F" (ATEX EEX ia II C T6. 8V).
En caja de aluminio ATEX Ex d II B T6- NAMUR IP 66.

Limit switch box

2 inductive sensors NCB2-V3-N0 "P+F" (ATEX EEX ia II C T6. 8V).
In aluminium ATEX Ex d II B T6 - NAMUR IP 66.

5987 10	-	1.5	271,08
---------	---	-----	---------------

Actuador no incluido. / Actuator not included.

5987 12	-	1.495	415,65
---------	---	-------	---------------

Actuador no incluido. / Actuator not included.



Información técnica
Technical information

Ref. 5987 20



Cabezal de control para Actuadores Neumáticos Rotativos On/Off con sensores, electroválvula y bus de comunicación AS-i

En caja de aluminio norma NAMUR - IP67- 24VDC.

Top controller for Pneumatic Actuators On/Off with sensors, solenoid and communication card AS-i

In aluminium NAMUR box - IP67- 24VDC.

5987 20	-	1.5	766,39
---------	---	-----	---------------



Información técnica
Technical information

Ref.5315



Información técnica
Technical information

Microrruptor final de carrera Electromecánico

Sobre válvula manual esfera ref. 2015, 2025, 2026, 2027, 2040, 2041, 2540E, 2541E, 2544, 2545
Ver art. 5987 02.

Limit switch box Electromechanical

Installed on a handle ball valve ref. 2015, 2025, 2026, 2027, 2040, 2041, 2540E, 2541E, 2544, 2545
See art. 5987 02

Microrruptor final de carrera con sensores Inductivos

Sobre válvula manual esfera ref. 2015, 2025, 2026, 2027, 2040, 2041, 2540E, 2541E, 2544, 2545
Ver art. 5987 04

Limit switch box with Inductive sensors

Installed on a handle ball valve ref. 2015, 2025, 2026, 2027, 2040, 2041, 2540E, 2541E, 2544, 2545
See art. 5987 04

Microrruptor final de carrera con sensores Inductivos (Atex)

Sobre válvula manual esfera ref. 2015, 2025, 2026, 2027, 2040, 2041, 2540E, 2541E, 2544, 2545
Ver art. 5987 08

Limit switch box with Inductive sensors (Atex)

Installed on as handle ball valve ref. 2015, 2025, 2026, 2027, 2040, 2041, 2540E, 2541E, 2544, 2545
See art. 5987 08

CÓDIGO CODE	MEDIDA SIZE	PESO WEIGHT	P.V.P. € PRICE €
5315 02 02	1/4"-1/2"	1.19	235,85
5315 05 02	3/4"-1"	0.8	235,85
5315 07 02	1 1/4"-2"	1.02	235,85
5315 10 02	2 1/2"-4"	0.835	235,85
Válvula no incluida. / Valve not included.			
5315 02 04	1/4" - 1/2"	0.8	258,10
5315 05 04	3/4" - 1"	0.8	258,10
5315 07 04	1 1/4" - 2"	1.006	258,10
5315 10 04	2 1/2" - 4"	0.835	258,10
Válvula no incluida. / Valve not included.			
5315 02 08	1/4"-1/2"	1.18	369,56
5315 05 08	3/4"-1"	0.86	369,56
5315 07 08	1 1/4"-2"	1.08	369,56
5315 10 08	2 1/2"-4"	0.835	369,56
Válvula no incluida. / Valve not included.			

Ref.5325



Información técnica
Technical information

Microrruptor final de carrera Electromecánico

Sobre válvula manual esfera ref. 2118-2119-2525
Ver art. 5987 02

Limit switch box Electromechanical

Installed on handle ball valve ref. 2118-2119-2525
See art. 5987 02

Microrruptor final de carrera con sensores inductivos

Sobre válvula manual esfera ref. 2118-2119-2525
Ver art. 5987 04

Limit switch box with inductive sensors

Installed on handle ball valve ref. 2118-2119-2525
See art. 5987 04

Microrruptor final de carrera con sensores inductivos (Atex)

Sobre válvula manual esfera ref. 2118-2119-2525
Ver art. 5987 08

Limit switch box with Inductive sensors (Atex)

Installed on handle ball valve ref. 2118-2119-2525
See art. 5987 08

5325 04 02	1/2" - 3/4"	0.8	235,85
5325 06 02	1" - 1 1/4"	0.8	235,85
5325 08 02	1 1/2" - 2"	0.81	235,85
5325 10 02	2 1/2" - 4"	0.835	235,85
Válvula no incluida. / Valve not included.			
5325 04 04	1/2" - 3/4"	0.8	258,10
5325 06 04	1" - 1 1/4"	0.8	258,10
5325 08 04	1 1/2" - 2"	0.81	258,10
5325 10 04	2 1/2" - 4"	0.835	258,10
Válvula no incluida. / Valve not included.			
5325 04 08	1/2" - 3/4"	0.8	369,56
5325 06 08	1" - 1 1/4"	0.8	369,56
5325 08 08	1 1/2" - 2"	0.81	369,56
5325 10 08	2 1/2" - 4"	0.835	369,56
Válvula no incluida. / Valve not included.			

Ref.5328



Información técnica
Technical information

Microrruptor final de carrera Electromecánico

Sobre válvula manual bridada ref. 2526A, 2528, 2528A, 2529
Ver art. 5987 02.

Limit switch box Electromechanical

Installed on flanged handle valve ref. 2526A, 2528, 2528A, 2529
See art. 5987 02.

Microrruptor final de carrera con sensores Inductivos

Sobre válvula manual bridada ref. 2526A, 2528, 2528A, 2529
Ver art. 5987 04.

Limit switch box with Inductive sensors

Installed on flanged handle valve ref. 2526A, 2528, 2528A, 2529
See art. 5987 04.

Microrruptor final de carrera con sensores Inductivos (Atex)

Sobre válvula manual bridada ref. 2526A, 2528, 2528A, 2529
Ver art. 5987 08.

Limit switch box with Inductive sensors (Atex)

Installed on flanged handle valve ref. 2526A, 2528, 2528A, 2529
See art. 5987 08.

5328 04 02	1/2"-3/4"	0.8	235,85
5328 06 02	1"	1.2	235,85
5328 07 02	1 1/4"-2"	0.81	235,85
5328 10 02	2 1/2"-4"	0.835	235,85
Válvula no incluida. / Valve not included.			
5328 04 04	1/2" - 3/4"	0.8	258,10
5328 06 04	1"	0.8	258,10
5328 07 04	1 1/4" - 2"	0.011	258,10
5328 10 04	2 1/2" - 4"	0.835	258,10
Válvula no incluida. / Valve not included.			
5328 04 08	1/2"-3/4"	0.8	369,56
5328 06 08	1"	0.8	369,56
5328 07 08	1 1/4"-2"	0.81	369,56
5328 10 08	2 1/2"-4"	0.835	369,56
Válvula no incluida. / Valve not included.			

Ref.5309

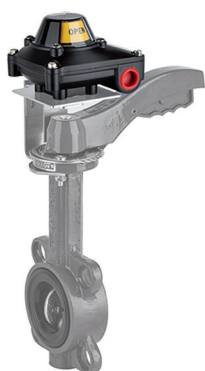

Microrruptor final de carrera Electromecánico

Sobre válvula manual mariposa ref. 2103, 2109
Ver art. 5987 02.

Limit switch box Electromechanical

Installed on handle butterfly valve ref. 2103, 2109
See art. 5987 02.

Microrruptor final de carrera con sensores Inductivos

Sobre válvula manual mariposa ref. 2103, 2109
Ver art. 5987 04.

Limit switch box with Inductive sensors

Installed on handle butterfly valve ref. 2103, 2109
See art. 5987 04.

Microrruptor final de carrera con sensores Inductivos (Atex)

Sobre válvula manual mariposa ref. 2103, 2109
Ver art. 5987 08.

Limit switch box with Inductive sensors (Atex)

Installed on handle butterfly valve ref. 2103, 2109
See art. 5987 08.

CÓDIGO CODE	MEDIDA SIZE	PESO WEIGHT	P.V.P. € PRICE €
5309 09 02	2" - 3"	1.66	235,85
5309 12 02	4" - 6"	0.925	235,85
5309 16 02	8"	0.855	235,85
5309 18 02	10"	0.855	235,85
Válvula no incluida. / Valve not included.			
5309 09 04	2" - 3"	0.815	258,10
5309 12 04	4" - 6"	1.08	258,10
5309 16 04	8"	0.855	258,10
5309 18 04	10"	0.855	258,10
Válvula no incluida. / Valve not included.			
5309 09 08	2" - 3"	0.815	369,56
5309 12 08	4" - 6"	0.815	369,56
5309 16 08	8"	0.855	369,56
5309 18 08	10"	0.855	369,56
Válvula no incluida. / Valve not included.			



Información técnica
Technical information

Ref. 5981 - 5982 - 5983



Microrruptor final de carrera Electromecánico

Sobre reductor manual ref. 5975, 5976, 5977
Ver art. 5987 02.

Limit switch box Electromechanical

Installed on gear operator ref. 5975, 5976, 5977
See art. 5987 02.

Microrruptor final de carrera con sensores Inductivos (Atex)

Sobre reductor manual ref. 5975, 5976, 5977
Ver art. 5987 08.

Limit switch box with Inductive sensors (Atex)

Installed on gear operator ref. 5975, 5976, 5977
See art. 5987 08.

Microrruptor final de carrera con sensores Inductivos

Sobre reductor manual ref. 5975, 5976, 5977
Ver art. 5987 04.

Limit switch box with Inductive sensors

Installed on gear operator ref. 5975, 5976, 5977
See art. 5987 04.

5981 00	5975**	0.9	122,86
5981 02	5976**	0.92	154,59
5981 04	5977**	0.95	214,48
*Reductor manual no incluido. **Referencia del reductor manual. / *Gear operator not included. **Gear operator reference.			
5982 00	5975**	0.001	321,30
5982 02	5976**	0.5	385,28
5982 04	5977**	-	-
5983 00	5975**	0.01	236,26
5983 02	5976**	-	-
5983 04	5977**	-	-
*Reductor manual no incluido. **Referencia del reductor manual. / *Gear operator not included. **Gear operator reference.			



Información técnica
Technical information

Ref.5989



Microrruptor final de carrera Electromecánico

Sobre reductor manual ref. 5984
Ver art. 5987 02

Limit switch box Electromechanical

Installed on gear operator ref. 5984
See art. 5987 02

Microrruptor final de carrera con sensores Inductivos

Sobre reductor manual ref. 5984
Ver art. 5987 04

Limit switch box with Inductive sensors

Installed on gear operator re. 5984
See art. 5987 04

Microrruptor final de carrera con sensores Inctivos (Atex)

Sobre reductor manual 5984
Ver art. 5987 08

Limit switch box with Inductive sensors (Atex)

Installed on gear operator ref. 5984
See art. 5987 08

5989 04 02	5984 04**	0.9	157,55
5989 05 02	5984 05**	0.9	157,55
5989 06 02	5984 06**	0.95	166,55
*Reductor manual no incluido. **Referencia del reductor manual. / *Gear operator not included. **Gear operator reference.			
5989 04 04	5984 04**	0.9	264,67
5989 05 04	5984 05**	0.9	264,67
5989 06 04	5984 06**	0.95	273,67
*Reductor manual no incluido. **Referencia del reductor manual. / *Gear operator not included. **Gear operator reference.			
5989 04 08	5984 04**	0.9	376,13
5989 05 08	5984 05**	0.9	376,13
5989 06 08	5984 06**	0.95	385,13
*Reductor manual no incluido. **Referencia del reductor manual. / *Gear operator not included. **Gear operator reference.			



Información técnica
Technical information

CÓDIGO CODE	MEDIDA SIZE	PESO WEIGHT	P.V.P. € PRICE €
----------------	----------------	----------------	---------------------

Ref.5988

Microrruptor final de carrera Electromecánico

Para válvula de asiento inclinado

Electromechanical Limit switch box

For angle seat valve

5988 01	-	0.216	163,17
---------	---	-------	--------

Válvula no incluida / Valve not included

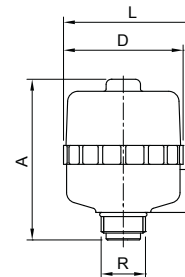

Información técnica
Technical information

Extensor para válvula automatizada - Actuador neumático

Extensión for automated valve - pneumatic actuator

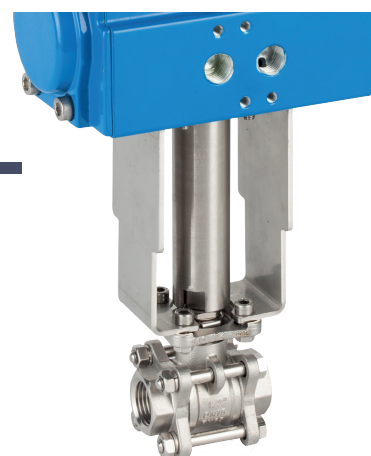

Ref.5334

Extensor para válvula automatizada (*)

(*) Válvula no incluida (consultar modelo de válvula)

Extension for automated valve (*)

(*) Valve not included (consult the model of the valve)

CÓDIGO CODE	MEDIDA SIZE	PESO WEIGHT	CAJA / BOX CARTON	P.V.P. € PRICE €
----------------	----------------	----------------	----------------------	---------------------

L= 50 mm

5334 09 050	L=50 mm	0.46	-	77,34
5334 11 050	L= 50 mm	0.38	-	77,34
5334 14 050	L=50 mm	0.457	-	85,75
5334 17 050	L=50 mm	0.7	-	100,23

L= 100 mm

5334 14 100	L= 100mm	0.84	-	111,99
5334 17 100	L= 100mm	1.116	-	134,09

Válvulas roscar - soldar / Threaded - welded valves

Ref.	ART.2015 - 2025 - 2026 - 2027	ART.2040 - 2041
5334 09 050	1/4" - 1/2"	1/4" - 1/2"
5334 11 050	3/4" - 1"	3/4" - 1"
5334 14 050	1 1/4" - 2"	1 1/4" - 2"
5334 17 050	2 1/2" - 4"	2 1/2"

Válvulas roscar - soldar / Threaded - welded valves

Ref.	ART.2015 - 2025 - 2026 - 2027	ART.2040 - 2041
5334 14 100	1 1/4" - 2"	1 1/4" - 2"
5334 17 100	2 1/2" - 4"	2 1/2"

Válvulas bridas / Flanged valves

Ref.	ART.2118 - 2119 - 2525	ART.2526A - 2528 - 2528A - 2529	ART.2540E - 2541E - 2544 - 2545
5334 09 050	1/2" - 3/4"	1/2"	*****
5334 11 050	1" - 1 1/4"	3/4" - 1"	1"
5334 14 100	1 1/2" - 2"	1 1/4" - 2"	1 1/4" - 2"
5334 17 100	2 1/2" - 4"	2 1/2" - 4"	2 1/2" - 4"



Información técnica
Technical information

Automatización y control

Automation and control

Válvulas equipadas con actuador eléctrico para accionamiento automático y a distancia

Valves equipped with electric actuator for automatic and remote operation

Características de los actuadores

Específicamente diseñados para aplicaciones de 1/4 de vuelta (90°) y reversibles, ideales para la automatización de válvulas de bola y mariposas. Resistentes a la corrosión. Mando manual de emergencia. Indicador visual de posición. Estos actuadores podemos ofrecerlos en tensión monofásica o trifásica dependiendo del modelo del mismo y además distintas tensiones y tipos de alimentación (AC o DC).

Characteristics of the actuators

Specifically designed for applications of 1/4 turn (90°) and reversible, ideal for the electric automation of ball valves and butterfly valves. Rust resistant. Emergency manual control. Visual position indicator. These actuators we can offer in different tension, single phase or three-phase depending of the model actuator and also different range of AC or DC voltage.

Características técnicas de actuador monofásico

Technical characteristics of single phase actuators

DESCRIPCIÓN DESCRIPTION	UNID. UNITS	GE-0 (S/B)	GE-05 (S/B)	GE-1 (S/B)	GE-15 (S/B)	GE-2 (S/B)	GE-2+ (S/B)
Tiempo maniobra en vacío (90°) + / - 10 % Operation time no load (90°) + / - 10%	Seg. Sec.	10	10	13	29	25	48
Par maniobra en operación / Operating torque	Nm.	20	35	55	85	140	300
Par máximo arranque / Maximum torque break	Nm.	25	38	60	90	170	140
Tiempo bajo tensión / Duty rating	%	75					
Protección IEC 60529 / Ip rating IEC 60529	-	IP-67					
Ángulo maniobra / Working angle	° (grados)	90° (Option 180° - 270°)					
Temperatura de trabajo / Working temperature	° C	-20° + 70°					
Interruptor final de carrera / Limit switch	-	4 SPDT micro					
Resistencia calefactora / Anti-condensation heater	W	3,5					
Conectores / Plugs	-	EN 175301 - 803 Form.A / DIN 43650/C					
Peso / Weight	Kg.	1.8	1.9	2.4	3	5.2	5.2
Voltaje / Voltage	V	SERIE " S ": 24 a 240 VCA / VCC / 24 to 240 VAC / VDC 50 / 60 Hz SERIE " B ": 12 VCA / VCC / 12 VAC / VDC 50 / 60 Hz					
Consumo a par máximo / Consumption at maximum torque	mA / W	Ver Ficha Técnica / See Data Sheet					

Todos los modelos están equipados con los siguientes elementos:

- Control térmico de la temperatura.
- Multivoltaje.
- Control electrónico de par.
- Mando manual de Emergencia.
- Control Visual de Operación (LED) modelos.
- Configuración conexión AC / DC.
- Contactos auxiliares.

Accesorios opcionales:

- Posicionador 4 / 20 mA.
- Bloque de Seguridad. Este dispositivo permite situar la válvula en posición preferente (N.C. ó N.A.) y garantiza un número de movimiento por fallo de suministro eléctrico.

All models are fitted with the following elements:

- Automatic temperature control.
- Autovoltage sensing.
- Electronic torque limiter.
- Manual override.
- Visual Control of operation (LED) models.
- Protected Electrical Supply AC / DC.
- Volt free contacts.

Optional accessories:

- Positioner 4 / 20 mA.
- Safety Lock. This device allows the valve to be placed in a preferential position (N.C. ó N.A.) and guarantee a number of movements in case the electric supply fails.

Características técnicas de actuador trifásico

Technical characteristics of three-phase actuators

DESCRIPCIÓN DESCRIPTION	UNID. UNITS	GE-010	GE-015	GE-025	GE-035	GE-050	GE-080	GE-110	GE-150	GE-200
Par máximo arranque Maximum torque break	Nm.	100	160	240	350	500	800	1100	1500	2000
Tiempo maniobra en vacío (90°) Operation time no load (90°)	Seg. Sec.	50Hz: 21 60Hz: 18	50Hz: 26 60Hz: 22	50Hz: 26 60Hz: 22	50Hz: 31 60Hz: 26	50Hz: 31 60Hz: 26	50Hz: 39 60Hz: 32	50Hz: 39 60Hz: 32	50Hz: 93 60Hz: 78	50Hz: 117 60Hz: 97
Peso / Weight	Kg.	7	13	13	18	18	23	23	58	65
Temperatura de trabajo Working temperature	°C	-20°/+70°								
Interruptor final de carrera Limit switch	-	4 SPDT								
Resistencia calefactora Anti-condensation heater	W	7-10								
Protección IEC 60529 Protection IEC 60529	-	IP- 67								

Todos los modelos están equipados con los siguientes elementos:

- Control térmico de la temperatura
- Control electrónico de par
- Mando manual de Emergencia
- Contactos auxiliares

Accesorios opcionales:

- Posicionador 4 / 20 mA
- Transmisor 4 / 20 mA
- Mando local / Remoto

All models are fitted with the following elements:

- Automatic temperature control
- Electronic torque limiter
- Manual override
- Volt free contacts

Optional accessories:

- Positioner 4 / 20 mA
- Transmitter 4 / 20 mA
- Remote and local position controller

Ref.5621



Válvula esfera 2 piezas

Características de válvula ver artículo 2015. Especificar tensión de alimentación necesaria.

2 pieces full bore ball valve

Valve characteristics see article 2015. Required voltage must be specified.

MED.	A	E	L	D
1/4"	221	169	181	110
3/8"	221	169	181	110
1/2"	221	169	181	110
3/4"	233	169	181	110
1"	239	169	181	110
1 1/4"	254	169	181	110
1 1/2"	266	169	181	110
2"	308	196	181	110

CÓDIGO CODE	MEDIDA SIZE	TIPO ACT. ACT. TYPE	PESO WEIGHT	P.V.P. € PRICE €
5621 02 51	1/4"	GE-0	2.66	374,91
5621 03 51	3/8"	GE-0	2.84	374,91
5621 04 51	1/2"	GE-0	3	376,31
5621 05 51	3/4"	GE-0	3.05	391,20
5621 06 51	1"	GE-0	3.34	401,17
5621 07 51	1 1/4"	GE-0	3.48	434,37
5621 08 47	1 1/2"	GE-05	4.3	556,90
5621 09 52	2"	GE-1	6.06	667,35

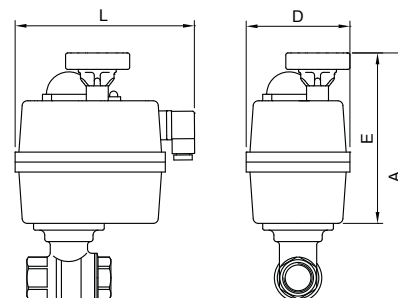

Información técnica
Technical information

Ref. 5635 - 5636 - 5637



Válvula esfera 3 piezas

Características de la válvula ver art. 2025 / 2026 / 2027. Especificar tensión de la alimentación necesaria.

3 pieces full bore ball valve

Valve characteristics see art. 2025 / 2026 / 2027. Required voltage must be specified.

MED.	A	E	L	D
1/4"	228	169	181	110
3/8"	228	169	181	110
1/2"	228	169	181	110
3/4"	237	169	181	110
1"	242	169	181	110
1 1/4"	259	169	181	110
1 1/2"	269	169	181	110
2"	308	196	181	110
2 1/2"	368	196	181	110
3"	389	196	181	110
4"	477	254	235	214

CÓDIGO CODE	MEDIDA SIZE	TIPO ACT. ACT. TYPE	PESO WEIGHT	P.V.P. € PRICE €
5635 02 51	1/4"	GE-0	2.81	377,84
5635 03 51	3/8"	GE-0	2.906	377,84
5635 04 51	1/2"	GE-0	2.61	380,36
5635 05 51	3/4"	GE-0	3.1	394,90
5635 06 51	1"	GE-0	3.86	403,59
5635 07 51	1 1/4"	GE-0	3.97	473,23
5635 08 47	1 1/2"	GE-05	5.42	571,95
5635 09 52	2"	GE-1	6.37	763,97
5635 10 52	2 1/2"	GE-1	12.04	966,17
5635 11 48	3"	GE-15	16.86	1294,16
5635 12 53	4"	GE-2	25.7	1855,94

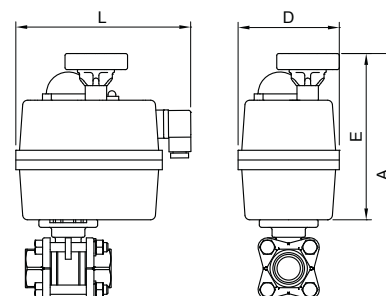

Información técnica
Technical information

Ref.5649



Válvula esfera 2 piezas

Características de válvula ver art. 3023 hasta 2". Ver art. 3029 de 2 1/2" a 4". Especificar tensión de alimentación necesaria.

2 pieces full bore ball valve

Valve characteristics see art. 2023 until 2". See art. 3029 from 2 1/2" to 4".

Required voltage must be specified.

MED.	A	E	L	D
1/2"	210	169	181	110
3/4"	210	169	181	110
1"	226	169	181	110
1 1/4"	239	169	181	110
1 1/2"	249	169	181	110
2"	269	169	181	110
2 1/2"	405	254	235	214
3"	431	254	235	214
4"	472	254	235	214

CÓDIGO CODE	MEDIDA SIZE	TIPO ACT. ACT. TYPE	PESO WEIGHT	P.V.P. € PRICE €
5649 04 51	1/2"	GE-0	1	385,17
5649 05 51	3/4"	GE-0	1.92	388,24
5649 06 51	1"	GE-0	2.82	400,74
5649 07 51	1 1/4"	GE-0	3.86	408,50
5649 08 51	1 1/2"	GE-0	3.76	419,20
5649 09 47	2"	GE-05	4.8	552,50
5649 10 53	2 1/2"	GE-2	8.85	1226,68
5649 11 53	3"	GE-2	10.3	1263,11
5649 12 54	4"	GE-2+	13.35	1571,20

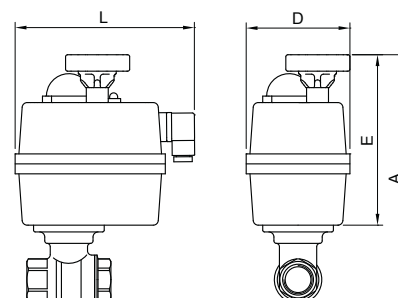

Información técnica
Technical information

Ref. 5672E - 5682E

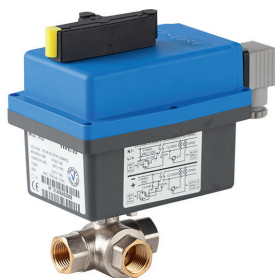

Válvula esfera 3 vías "L" o "T"

Características de válvula ver art. 3272E / 3282E. Especificar tensión de alimentación necesaria. Solamente giro 0° - 90° (On - Off)

"L" or "T" 3 ways ball valve

Valve characteristics see art. 3272E / 3282E. Required voltage must be specified. Only 0° - 90° (On - Off)

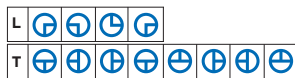

CÓDIGO CODE	MEDIDA SIZE	TIPO ACT. ACT. TYPE	PESO WEIGHT	P.V.P. € PRICE €
5672E 04 51	1/2"	GE-0	2.249	331,11
5672E 05 51	3/4"	GE-0	2.481	345,47
5672E 06 51	1"	GE-0	3.72	371,55
5682E 04 51	1/2"	GE-0	2	331,11
5682E 05 51	3/4"	GE-0	2.2	345,47
5682E 06 51	1"	GE-0	2.781	371,55

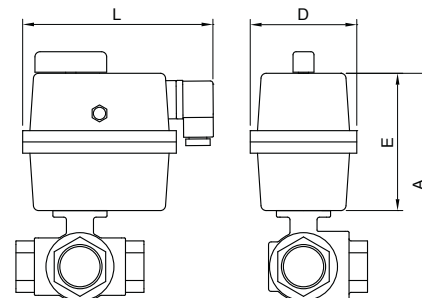

Información técnica
Technical information

Ref. 5640 - 5641



Válvula esfera 3 vías "L" o "T"

Características de la válvula ver artículo 2040 / 2041. Especificar tensión de alimentación necesaria.

"L" or "T" 3 ways reduced bore ball valve

Valve characteristics see article 2040 / 2041. Required voltage must be specified.

MED.	A	E	L	D
1/4"	201	146	150	96
3/8"	224	169	181	110
1/2"	224	169	181	110
3/4"	231	169	181	110
1"	241	169	181	110
1 1/4"	261	169	181	110
1 1/2"	269	169	181	110
2"	316	196	181	110
2 1/2"	346	196	181	110



L				
5640 02 51	1/4"	GE-0	3.05	445,16
5640 03 51	3/8"	GE-0	2.5	445,16
5640 04 51	1/2"	GE-0	3.5	447,04
5640 05 51	3/4"	GE-0	3.78	462,95
5640 06 51	1"	GE-0	4.26	578,22
5640 07 51	1 1/4"	GE-0	5.42	651,84
5640 08 47	1 1/2"	GE-05	6.9	849,94
5640 09 52	2"	GE-1	9.34	1130,95
5640 10 48	2 1/2"	GE-15	13	1608,89
T				
5641 02 51	1/4"	GE-0	2.5	445,16
5641 03 51	3/8"	GE-0	2.5	445,16
5641 04 51	1/2"	GE-0	2.99	447,04
5641 05 51	3/4"	GE-0	3.64	462,95
5641 06 51	1"	GE-0	3.92	578,22
5641 07 51	1 1/4"	GE-0	5.42	651,84
5641 08 47	1 1/2"	GE-05	5.8	849,94
5641 09 52	2"	GE-1	9.06	1130,95
5641 10 48	2 1/2"	GE-15	12.86	1608,89

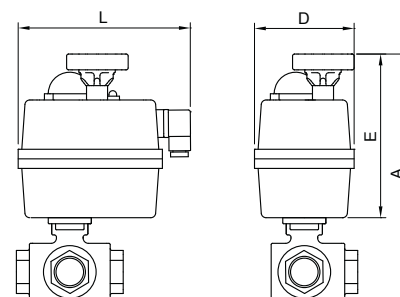

Información técnica
Technical information

Ref. 5642E - 5643E



Válvula esfera 3 vías bridada "L" o "T"

Características de la válvula ver artículo 2540E / 2541E.

"L" or "T" 3 ways ball valve with flanges

Valve characteristics see article 2540E / 2541E.

MED.	A	E	L	D
1"	229,5	171	177	110
1 1/4"	242	171	177	110
1 1/2"	273,5	196	177	110
2"	281	196	177	110
2 1/2"	306	196	177	128
3"	376,5	254	235	214
4"	399,5	254	235	214

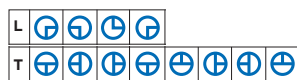

CÓDIGO CODE	MEDIDA SIZE	TIPO ACT. ACT. TYPE	PESO WEIGHT	P.V.P. € PRICE €
----------------	----------------	------------------------	----------------	---------------------

L				
5642E 06 51	1"	GE-0	8.06	822,24
5642E 07 47	1 1/4"	GE-05	14.8	977,22
5642E 08 52	1 1/2"	GE-1	15.76	1195,18
5642E 09 52	2"	GE-1	20.2	1475,15
5642E 10 48	2 1/2"	GE-15	24.7	2524,55
5642E 11 53	3"	GE-2	37.3	3482,43
5642E 12 54	4"	GE-2+	51.14	4979,97

T				
5643E 06 51	1"	GE-0	0.001	-
5643E 07 47	1 1/4"	GE-05	11.94	977,22
5643E 08 52	1 1/2"	GE-1	15.58	1195,18
5643E 09 52	2"	GE-1	20.02	1475,15
5643E 10 48	2 1/2"	GE-15	29	2524,55
5643E 11 53	3"	GE-2	36.5	3482,43
5643E 12 54	4"	GE-2+	48.44	4979,97

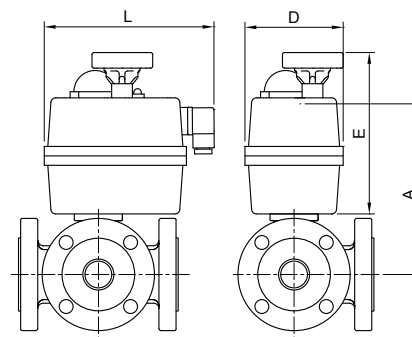

Información técnica
Technical information

Ref. 5644 - 5645



Válvula esfera 3 vías bridada "L" o "T"

Características de la válvula ver artículo 2544 / 2545.

"L" or "T" 3 ways ball valve flanged ends

Valve characteristics see article 2544 / 2545.

MED.	A	E	L	D
1"	230	171	177	110
1 1/4"	242	171	177	110
1 1/2"	274	196	177	110
2"	281	196	177	110
2 1/2"	306	196	177	128
3"	377	254	235	214
4"	400	254	235	214

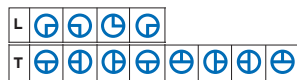

L				
5644 06 51	1"	GE-0	10.41	668,06
5644 07 47	1 1/4"	GE-05	12.02	838,79
5644 08 52	1 1/2"	GE-1	15.58	991,95
5644 09 52	2"	GE-1	20.2	1182,90
5644 10 48	2 1/2"	GE-15	24.7	1910,84
5644 11 53	3"	GE-2	37.3	2597,78
5644 12 54	4"	GE-2+	51.14	3723,01

T				
5645 06 51	1"	GE-0	8.04	668,06
5645 07 47	1 1/4"	GE-05	11.94	838,79
5645 08 52	1 1/2"	GE-1	15.58	991,95
5645 09 52	2"	GE-1	20.02	1182,90
5645 10 48	2 1/2"	GE-15	24	1910,84
5645 11 53	3"	GE-2	36.5	2597,78
5645 12 54	4"	GE-2+	48.44	3723,01

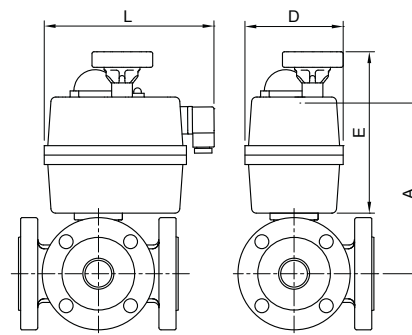

Información técnica
Technical information

Ref.5625



Válvula esfera 2 piezas bridada

Características de la válvula ver artículo 2525. Especificar tensión de alimentación necesaria.

2 pieces full bore ball valve - flanged ends

Valve characteristics see article 2525. Required voltage must be specified.

MED.	A	E	L	D
1/2"	204	169	181	110
3/4"	274	196	181	110
1"	284	169	181	110
1 1/4"	247	146	150	96
1 1/2"	270	164	155	99
2"	362	196	181	110
2 1/2"	303	164	155	99
3"	426	196	181	110
4"	509	196	181	110

CÓDIGO CODE	MEDIDA SIZE	TIPO ACT. ACT. TYPE	PESO WEIGHT	P.V.P. € PRICE €
5625 04 51	1/2"	GE-0	4.15	424,59
5625 05 51	3/4"	GE-0	4.8	434,15
5625 06 51	1"	GE-0	5.5	458,56
5625 07 47	1 1/4"	GE-05	0.001	592,96
5625 08 52	1 1/2"	GE-1	10.65	680,39
5625 09 52	2"	GE-1	11.9	708,81
5625 10 48	2 1/2"	GE-15	17.26	1113,21
5625 11 53	3"	GE-2	25.45	1360,28
5625 12 54	4"	GE-2+	29	1776,39

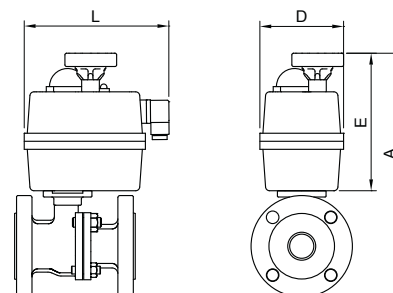

Información técnica
Technical information

Ref.5625



Válvula esfera 2 piezas bridada

Características de la válvula ver artículo 2525. Servomotor trifásico (3-400 V). Otro voltaje consultar

2 pieces full bore ball valve - flanged ends

Valve characteristics see article 2525. Triphasic servomotor (3-400 V). Other voltage please consult us.

MED.	A	E	L	D
4"	505	259	229	338
5"	579	259	229	338
6"	648	288	244	357
8"	733	313	284	380

5625 12 55	4"	GE-025	40	2182,29
5625 13 55	5"	GE-025	49.32	2880,56
5625 14 56	6"	GE-035	78.8	3514,74
5625 16 57	8"	GE-080	140	5916,21

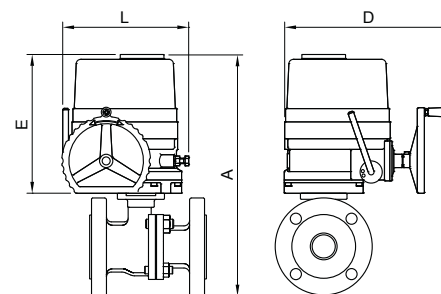

Información técnica
Technical information

Ref.5626A



Válvula esfera 2 piezas bridada

Características de la válvula ver artículo 2526A. Especificar tensión de alimentación necesaria.

2 pieces full bore ball valve - flanged ends

Valve characteristics see article 2526A. The required tension supply to be specified.

MED.	A	E	L	D
1/2"	204	169	181	110
3/4"	274	169	181	110
1"	284	169	181	110
1 1/4"	311	169	181	110
1 1/2"	252	146	150	96
2"	362	196	181	110
2 1/2"	407	196	181	110
3"	311	164	155	99
4"	509	196	181	110

5626A 04 51	1/2"	GE-0	3.45	428,12
5626A 05 51	3/4"	GE-0	4	443,87
5626A 06 51	1"	GE-0	5.8	468,39
5626A 07 51	1 1/4"	GE-0	6.65	513,21
5626A 08 47	1 1/2"	GE-05	9.25	646,53
5626A 09 52	2"	GE-1	13.4	808,71
5626A 10 52	2 1/2"	GE-1	16.75	1005,62
5626A 11 48	3"	GE-15	21.2	1366,09
5626A 12 53	4"	GE-2	33.25	1974,95

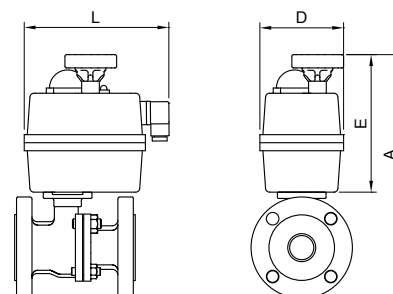

Información técnica
Technical information

Ref.5626A



Válvula esfera 2 piezas bridada

Características de la válvula ver artículo 2526A. Servomotor trifásico (3-400 V). Otro voltaje consultar.

2 pieces full bore ball valve - flanged ends

Valve characteristics see article 2526A. Triphasic servomotor (3-400 V). Other voltage please consult us.

MED.	A	E	L	D
4"	514	259	229	338
6"	608	288	244	357

CÓDIGO CODE	MEDIDA SIZE	TIPO ACT. ACT. TYPE	PESO WEIGHT	P.V.P. € PRICE €
5626A 12 55	4"	GE-025	44.5	2421,75
5626A 14 56	6"	GE-035	74.5	4301,22

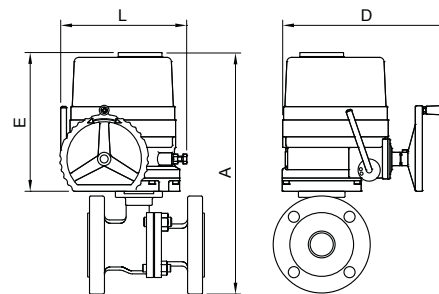

Información técnica
Technical information

Ref.5628



Válvula esfera 2 piezas bridada

Características de la válvula ver artículo 2528. Especificar tensión de alimentación necesaria.

2 pieces full bore ball valve - flanged ends

Valve characteristics see article 2528. The required tension supply to be specified.

MED.	A	E	L	D
1/2"	204	169	181	110
3/4"	274	169	181	110
1"	284	169	181	110
1 1/4"	311	169	181	110
1 1/2"	252	146	150	96
2"	362	196	181	110
2 1/2"	407	196	181	110
3"	311	164	155	99
4"	509	196	181	110

5628 04 51	1/2"	GE-0	4.2	487,19
5628 05 51	3/4"	GE-0	4.95	511,13
5628 06 51	1"	GE-0	6.7	549,16
5628 07 51	1 1/4"	GE-0	8.36	651,16
5628 08 47	1 1/2"	GE-05	7.9	799,49
5628 09 52	2"	GE-1	14.5	974,83
5628 10 52	2 1/2"	GE-1	18.1	1246,42
5628 11 48	3"	GE-15	21.2	1639,25
5628 12 53	4"	GE-2	33.24	2263,66

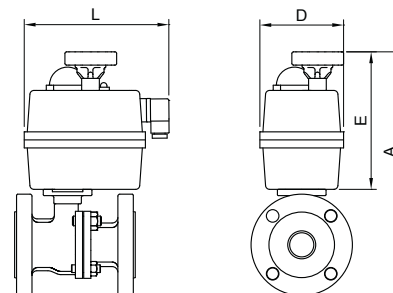

Información técnica
Technical information

Ref.5628



Válvula esfera 2 piezas bridada

Características de la válvula ver artículo 2528. Servomotor trifásico (3-400 V). Otro voltaje consultar.

2 pieces full bore ball valve - flanged ends

Valve characteristics see article 2528. Triphasic servomotor (3-400 V). Other voltage please consult us.

MED.	A	E	L	D
4"	514	259	229	338
5"	579	259	229	338
6"	648	288	244	357
8"	733	313	284	380

5628 12 55	4"	GE-025	40	2898,20
5628 13 55	5"	GE-025	65	4232,97
5628 14 56	6"	GE-035	78.8	5442,06
5628 16 57	8"	GE-080	140	10570,14

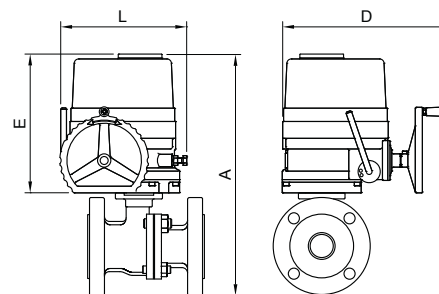

Información técnica
Technical information

Ref.5628A



Válvula esfera 2 piezas bridada

Características de válvula ver art. 2528A. Especificar tensión de alimentación necesaria.

2 piezas full bore ball valve - flanges ends

Valve characteristics see art. 2528A. Required voltage must be specified.

MED.	A	E	L	D
1/2"	204	169	181	110
3/4"	274	169	181	110
1"	284	169	181	110
1 1/4"	311	169	181	110
1 1/2"	252	146	150	96
2"	362	196	181	110
2 1/2"	407	196	181	110
3"	311	164	155	99
4"	509	196	181	110

CÓDIGO CODE	MEDIDA SIZE	TIPO ACT. ACT. TYPE	PESO WEIGHT	P.V.P. € PRICE €
5628A 04 51	1/2"	GE-0	3.45	464,67
5628A 05 51	3/4"	GE-0	4	487,80
5628A 06 51	1"	GE-0	5.8	533,19
5628A 07 51	1 1/4"	GE-0	0.001	643,75
5628A 08 47	1 1/2"	GE-05	7.05	767,24
5628A 09 52	2"	GE-1	10.2	944,05
5628A 10 52	2 1/2"	GE-1	0.001	1421,52
5628A 11 48	3"	GE-15	21.2	1676,99
5628A 12 53	4"	GE-2	33.25	2362,69

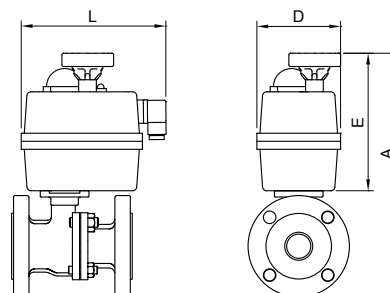

Información técnica
Technical information

Ref.5628A



Válvula esfera 2 piezas bridada

Características de la válvula ver artículo 2528A. Servomotor trifásico (3-400 V). Otro voltaje consultar.

2 piezas full bore ball valve - flanges ends

Valve characteristics see article 2528A. Triphasic servomotor (3-400 V). Other voltaje please consult us.

MED.	A	E	L	D
4"	509	259	229	338
6"	595	288	244	357
8"	676	313	284	380

5628A 12 55	4"	GE-025	44.25	3187,94
5628A 14 56	6"	GE-035	85.95	5901,80
5628A 16 57	8"	GE-080	141.3	11336,06

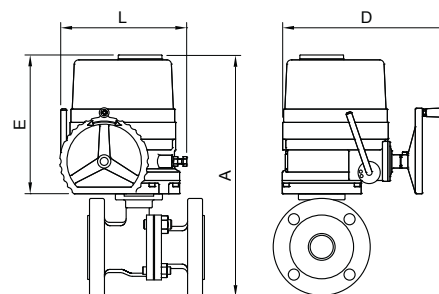

Información técnica
Technical information

Ref.5629



Válvula esfera 2 piezas bridada

Características de la válvula ver artículo 2529. Especificar tensión de alimentación necesaria.

2 piezas full bore ball valve - flanges ends

Valve characteristics see article 2529. Required voltage must be specified.

MED.	A	E	L	D
2 1/2"	407	196	181	110
3"	311	164	155	99
4"	509	196	181	110

5629 10 52	2 1/2"	GE-1	19.8	1639,58
5629 11 48	3"	GE-15	25.86	2169,67
5629 12 53	4"	GE-2	36.45	3136,73

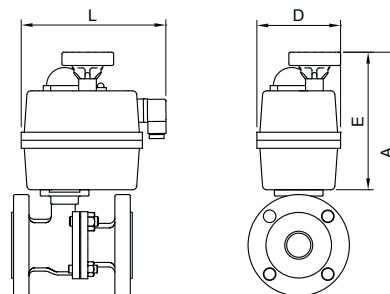

Información técnica
Technical information

CÓDIGO CODE	MEDIDA SIZE	TIPO ACT. ACT. TYPE	PESO WEIGHT	P.V.P. € PRICE €
----------------	----------------	------------------------	----------------	---------------------

Ref.5629



Válvula esfera 2 piezas bridada

Características de la válvula ver artículo 2529. Servomotor trifásico (3-400 V). Otro voltaje consultar.

2 pieces full bore ball valve - flanges ends

Valve characteristics see article 2529. . Triphasic servomotor (3-400 V). Other voltage please consult us.

MED.	A	E	L	D
4"	534	259	229	338
5"	608	288	244	357
6"	663	313	284	380

5629 12 55	4"	GE-025	47.25	3378,00
5629 13 56	5"	GE-035	81.45	5408,65
5629 14 57	6"	GE-080	107.06	7422,43

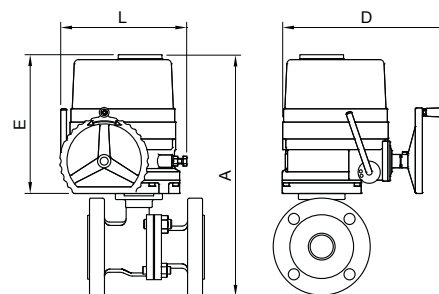

Información técnica
Technical information

Ref.5605



Válvula esfera 1 pieza tipo wafer

Características de la válvula ver artículo 2105. Especificar tensión de alimentación necesaria.

1 piece wafer type ball valve - flanges ends

Valve characteristics see article 2105. Required voltage must be specified.

MED.	A	E	L	D
1"	272	146	150	96
1 1/4"	307	164	164	99
1 1/2"	321	164	164	99
2"	336	164	164	99
2 1/2"	446	247	200	200
3"	473	247	200	200
4"	507	247	200	200

5605 06 51	1"	GE-0	4.2	518,93
5605 07 52	1 1/4"	GE-1	5.6	735,20
5605 08 52	1 1/2"	GE-1	8.3	767,16
5605 09 52	2"	GE-1	9.8	809,14
5605 10 53	2 1/2"	GE-2	20.2	1443,10
5605 11 53	3"	GE-2	25.1	1580,14
5605 12 54	4"	GE-2+	35	2089,68

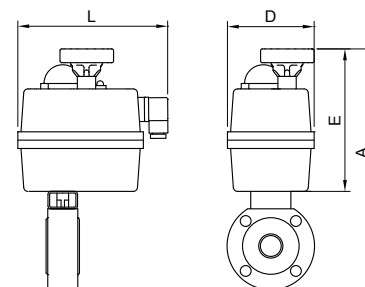

Información técnica
Technical information

Ref.5615



Válvula esfera 1 pieza tipo wafer con cámara de calefacción

Características de la válvula ver artículo 2115. Especificar tensión de alimentación necesaria.

1 piece wafer type ball valve - flanges ends

Valve characteristics see article 2115. Required voltage must be specified.

MED.	A	E	L	D
1"	272	146	150	96
1 1/4"	307	164	164	99
1 1/2"	321	164	164	99
2"	336	164	164	99
2 1/2"	446	247	200	200
3"	473	247	200	200
4"	507	247	200	200

5615 06 51	1"	GE-0	4.65	658,47
5615 07 52	1 1/4"	GE-1	6.15	877,43
5615 08 52	1 1/2"	GE-1	8.9	944,54
5615 09 52	2"	GE-1	10.5	1007,34
5615 10 53	2 1/2"	GE-2	21.15	1706,91
5615 11 53	3"	GE-2	26.5	1873,94
5615 12 54	4"	GE-2+	37.05	2456,08

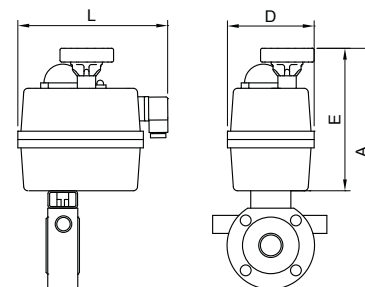

Información técnica
Technical information

Ref.5618



Válvula esfera 1 pieza tipo wafer

Características de la válvula ver artículo 2118. Especificar tensión de alimentación necesaria.

1 piece ball valve wafer type

Valve characteristics see article 2118. Required voltage must be specified.

MED.	A	E	L	D
1/2"	272	169	181	110
3/4"	282	169	181	110
1"	286	169	181	110
1 1/4"	309	169	181	110
1 1/2"	320	169	181	110
2"	362	196	181	110
2 1/2"	382	196	181	110
3"	406	196	181	110
4"	486	196	181	110

CÓDIGO CODE	MEDIDA SIZE	TIPO ACT. ACT. TYPE	PESO WEIGHT	P.V.P. € PRICE €
5618 04 51	1/2"	GE-0	3	520,63
5618 05 51	3/4"	GE-0	3.5	541,52
5618 06 51	1"	GE-0	4	571,46
5618 07 51	1 1/4"	GE-0	5	703,26
5618 08 47	1 1/2"	GE-05	6.15	807,87
5618 09 52	2"	GE-1	9.04	950,19
5618 10 52	2 1/2"	GE-1	9.8	1466,75
5618 11 48	3"	GE-15	12.3	1712,37
5618 12 53	4"	GE-2	23.2	2471,52

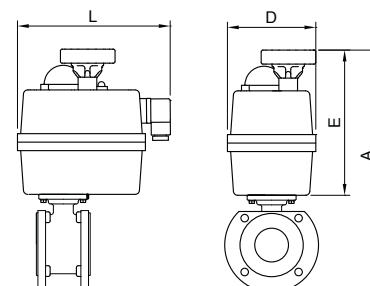

Información técnica
Technical information

Ref.5919



Valvula esfera 1 pieza tipo wafer con cámara de calefacción

Características de la válvula ver artículo 2119. Especificar tensión de alimentación necesaria.

1 piece ball valve with heating chamber

Valve characteristics see article 2119. Required voltage must be specified.

MED.	A	E	L	D
1/2"	272	169	181	110
3/4"	282	169	181	110
1"	286	169	181	110
1 1/4"	309	169	181	110
1 1/2"	382	196	181	110
2"	362	196	181	110
2 1/2"	382	196	181	110
3"	406	196	181	110
4"	486	196	181	110

5919 04 51	1/2"	GE-0	3.1	775,26
5919 05 51	3/4"	GE-0	3.61	795,37
5919 06 51	1"	GE-0	4.15	901,34
5919 07 51	1 1/4"	GE-0	5.25	1037,62
5919 08 47	1 1/2"	GE-05	6.5	1146,86
5919 09 52	2"	GE-1	7.9	1299,91
5919 10 52	2 1/2"	GE-1	10.55	1819,35
5919 11 48	3"	GE-15	13.3	2078,11
5919 12 53	4"	GE-2	24.5	2946,26

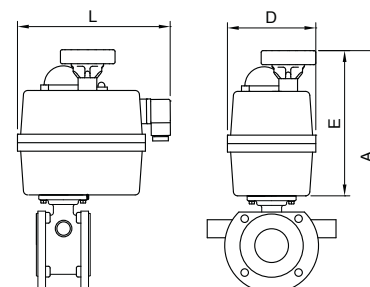

Información técnica
Technical information

Ref.5633



Válvula mariposa tipo wafer

Características de la válvula ver artículo 2103. Servomotor trifásico (3-400 V). Otro voltaje consultar.

Wafer type butterfly valve

Valve characteristics see article 2103. Triphasic servomotor (3-400 V). Other voltage please consult us.

MED.	A	E	L	D
5"	595	220	172	258
6"	659	259	229	338
8"	709	259	229	338
10"	818	288	244	357
12"	898	288	244	357
14"	963	313	287	380
16"	1033	313	287	380
18"	1281	506	293	368
20"	1381	531	312	380

5633 13 58	5"	GE-010	15.75	1337,22
5633 14 59	6"	GE-015	0.01	1661,30
5633 16 55	8"	GE-025	31.9	1773,78
5633 18 56	10"	GE-035	39.5	2126,34
5633 20 62	12"	GE-050	43.7	2559,83
5633 22 57	14"	GE-080	0.001	2951,30
5633 24 60	16"	GE-110	0.001	4034,94
5633 26 64	18"	GE-150	183.5	5694,71
5633 28 61	20"	GE-210	226.5	6903,57

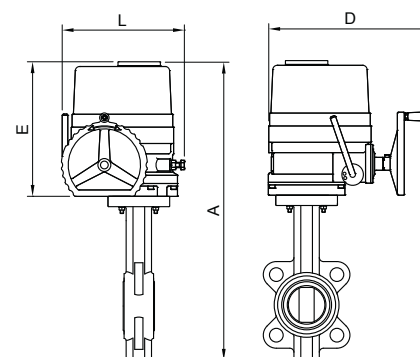

Información técnica
Technical information

Ref.5633



Válvula mariposa tipo wafer

Características de la válvula ver artículo 2103. Especificar tensión de alimentación necesaria.

Wafer type butterfly valve

Valve characteristics see article 2103. Required voltage must be specified.

DN	A	E	L	D
50	435	196	177	110
65	449	196	177	110
80	464	196	177	110
100	501	196	177	110
125	538	196	177	110
150	614	254	215	214
200	684	254	215	214

CÓDIGO CODE	MEDIDA SIZE	TIPO ACT. ACT. TYPE	PESO WEIGHT	P.V.P. € PRICE €
5633 09 52	2"	GE-1	6.3	575,85
5633 10 52	2 1/2"	GE-1	7.2	585,48
5633 11 52	3"	GE-1	7.54	652,84
5633 12 48	4"	GE-15	10	870,51
5633 13 48	5"	GE-15	11.2	1042,48
5633 14 53	6"	GE-2	15.3	1154,77
5633 16 54	8"	GE-2+	17.65	1395,89

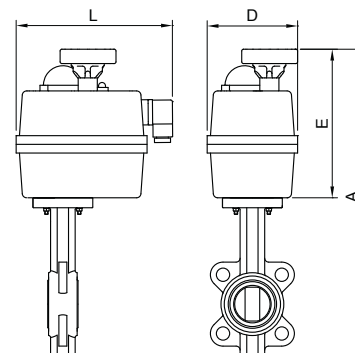

Información técnica
Technical information

Ref.5639



Válvula mariposa tipo wafer

Características de la válvula ver artículo 2109. Servomotor trifásico (3-400 V). Otro voltaje consultar.

Wafer type butterfly valve

Valve characteristics see article 2109. Triphasic servomotor (3-400 V). Other voltage please consult us.

MED.	A	E	L	D
5"	595	220	172	258
6"	659	259	229	338
8"	709	259	229	338
10"	818	288	244	357
12"	898	288	244	357
14"	963	313	287	380
16"	1033	313	287	380
18"	1281	506	293	368
20"	1381	531	312	380

5639 13 58	5"	GE-010	14.5	1366,08
5639 14 59	6"	GE-015	26.15	1760,48
5639 16 55	8"	GE-025	31.9	1960,24
5639 18 56	10"	GE-035	39.5	2158,95
5639 20 62	12"	GE-050	46.15	2581,68
5639 22 57	14"	GE-080	86	3181,81
5639 24 60	16"	GE-110	107	4644,57
5639 26 64	18"	GE-150	183.5	7064,40
5639 28 61	20"	GE-210	226.5	8158,92

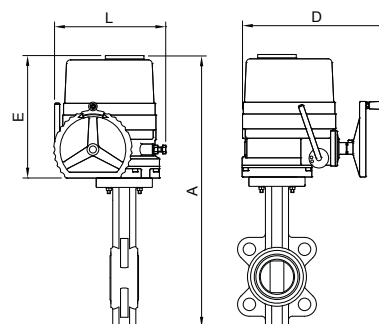

Información técnica
Technical information

Ref.5639



Válvula mariposa tipo wafer

Características de la válvula ver artículo 2109. Especificar tensión de alimentación necesaria.

Wafer type butterfly valve

Valve characteristics see article 2109. Required voltage must be specified.

DN	A	E	L	D
50	435	196	177	110
65	449	196	177	110
80	464	196	177	110
100	501	196	177	110
125	538	196	177	110
150	614	254	215	214
200	684	254	215	214

5639 09 52	2"	GE-1	6.3	585,31
5639 10 52	2 1/2"	GE-1	6.7	597,21
5639 11 52	3"	GE-1	7.4	669,53
5639 12 48	4"	GE-15	9.18	903,39
5639 13 48	5"	GE-15	11.2	1025,05
5639 14 53	6"	GE-2	12.25	1212,81
5639 16 54	8"	GE-2+	21.1	1528,57

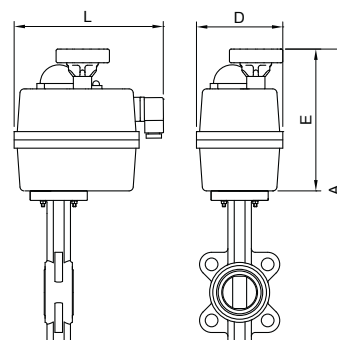

Información técnica
Technical information

Ref.5611



Válvula mariposa tipo wafer

Características de la válvula ver artículo 2101. Especificar tensión de alimentación necesaria.

Butterfly valve wafer type

Valve characteristics see article 2101. Required voltage must be specified.

MED.	A	E	L	D
2"	389	169	181	110
2 1/2"	435	196	181	110
3"	449	196	181	110
4"	486	196	181	110
5"	571	254	235	214
6"	603	254	235	214

CÓDIGO CODE	MEDIDA SIZE	TIPO ACT. ACT. TYPE	PESO WEIGHT	P.V.P. € PRICE €
5611 09 47	2"	GE-05	5.82	810,47
5611 10 52	2 1/2"	GE-1	6.08	903,46
5611 11 52	3"	GE-1	6.64	1045,68
5611 12 48	4"	GE-15	11.83	1458,48
5611 13 53	5"	GE-2	12.87	1822,74
5611 14 54	6"	GE-2+	12.54	2266,36

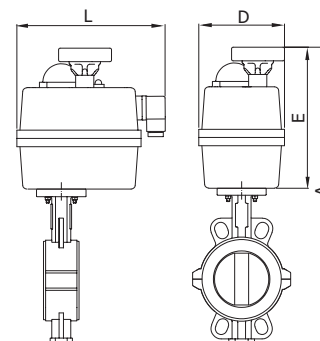

Información técnica
Technical information

Ref.5611



Válvula mariposa tipo wafer

Características de la válvula ver artículo 2101. Servomotor trifásico (3-400 V). Otro voltaje consultar.

Butterfly valve wafer type

Valve characteristics see article 2101. Triphasic servomotor (3-400 V). Other voltaje please consult us.

MED.	A	E	L	D
4"	510	220	172	258
5"	576	259	229	338
6"	608	259	229	338
8"	699	288	244	357

5611 12 58	4"	GE-010	13.63	1789,17
5611 13 59	5"	GE-015	22.67	2201,07
5611 14 55	6"	GE-025	22.34	2528,32
5611 16 62	8"	GE-050	33.98	3736,71

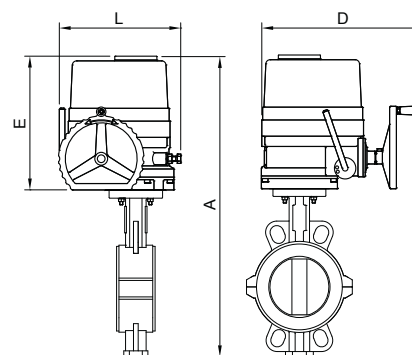

Información técnica
Technical information

Ref.5611T **NEW**



Válvula mariposa tipo wafer

Características de la válvula ver artículo 2101T. Especificar tensión de alimentación necesaria.

Butterfly valve wafer type

Valve characteristics see article 2101T. Required voltage must be specified.

MED.	A	E	L	D
2"	389	169	181	110
2 1/2"	435	196	181	110
3"	449	196	181	110
4"	486	196	181	110
5"	571	254	235	214
6"	603	254	235	214

5611T 09 47	2"	GE-05	5.82	-
5611T 10 52	2 1/2"	GE-1	6.08	-
5611T 11 52	3"	GE-1	6.64	-
5611T 12 48	4"	GE-15	11.83	-
5611T 13 53	5"	GE-2	12.87	-
5611T 14 54	6"	GE-2+	12.54	-

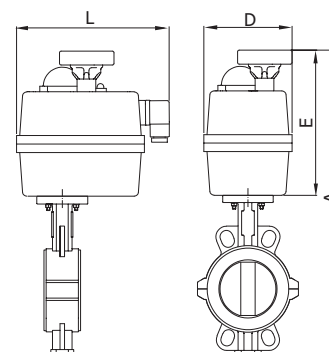

Información técnica
Technical information

Ref.5611T **NEW**



Válvula mariposa tipo wafer

Características de la válvula ver artículo 2101T. Servomotor trifásico (3-400 V). Otro voltaje consultar.

Butterfly valve wafer type

Valve characteristics see article 2101T. Triphasic servomotor (3-400 V). Other voltage please consult us.

MED.	A	E	L	D
4"	510	220	172	258
5"	576	259	229	338
6"	608	259	229	338
8"	699	288	244	357

CÓDIGO CODE	MEDIDA SIZE	TIPO ACT. ACT. TYPE	PESO WEIGHT	P.V.P. € PRICE €
5611T 12 58	4"	GE-010	13.63	-
5611T 13 59	5"	GE-015	22.67	-
5611T 14 55	6"	GE-025	22.34	-

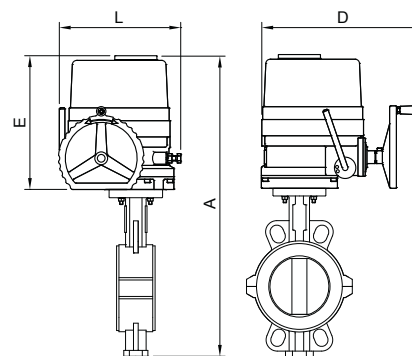

Información técnica
Technical information

Ref.5634



Válvula mariposa tipo wafer inoxidable

Características de la válvula ver artículo 2104. Especificar tensión de alimentación necesaria.

Stainless steel butterfly valve wafer type

Valve characteristics see article 2104. Required voltage must be specified.

MED.	A	E	L	D
2"	379	169	181	110
2 1/2"	416	196	181	110
3"	424	196	181	110
4"	470	196	181	110
5"	557	254	235	214
6"	601	254	235	214

5634 09 47	2"	GE-05	5.4	974,59
5634 10 52	2 1/2"	GE-1	6.2	1143,01
5634 11 52	3"	GE-1	6.7	1276,29
5634 12 48	4"	GE-15	9.74	1727,62
5634 13 53	5"	GE-2	0.01	2158,66
5634 14 54	6"	GE-2+	15.16	2725,38

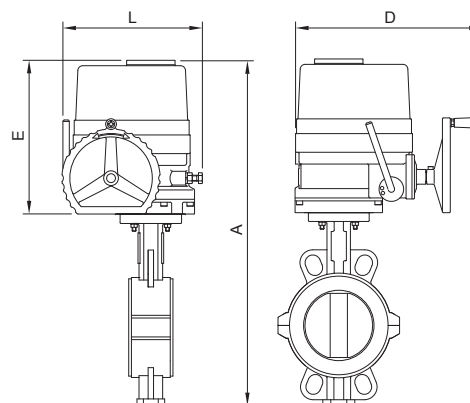

Información técnica
Technical information

Ref.5634



Válvula mariposa tipo wafer inoxidable

Características de la válvula ver artículo 2104. Servomotor trifásico (3-400 V). Otro voltaje consultar.

Stainless steel butterfly valve wafer type

Valve characteristics see article 2104. Triphasic servomotor (3-400 V). Other voltage please consult us.

MED.	A	E	L	D
4"	494	220	172	258
5"	565	259	229	338
6"	594	259	229	338
8"	697	288	244	357
10"	-	-	-	-

5634 12 58	4"	GE-010	1	2175,02
5634 13 59	5"	GE-015	0.01	2547,89
5634 14 55	6"	GE-025	0.01	3093,75
5634 16 62	8"	GE-050	1	4491,33
5634 18 60	10"	GE-110	41.5	6586,42

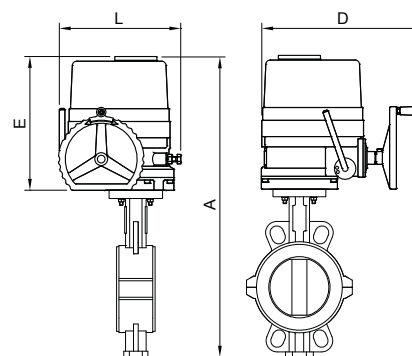

Información técnica
Technical information

Ref.5608



Válvula mariposa tipo LUG DIN

Características de la válvula ver artículo 2108. Especificar tensión de alimentación necesaria.

Butterfly valve DIN LUG type

Valve characteristics see article 2108. Required voltage must be specified.

MED.	A	E	L	D
2"	436	196	181	110
2 1/2"	449	196	181	110
3"	464	196	181	110
4"	501	196	181	110
5"	539	196	181	110
6"	622	254	235	214
8"	684	254	235	214

CÓDIGO CODE	MEDIDA SIZE	TIPO ACT. ACT. TYPE	PESO WEIGHT	P.V.P. € PRICE €
5608 09 52	2"	GE-1	6.7	592,56
5608 10 52	2 1/2"	GE-1	7.3	605,66
5608 11 52	3"	GE-1	9.34	651,43
5608 12 48	4"	GE-15	10.05	830,18
5608 13 48	5"	GE-15	13.3	1059,16
5608 14 53	6"	GE-2	18.5	1208,14
5608 16 54	8"	GE-2+	23.4	1567,18

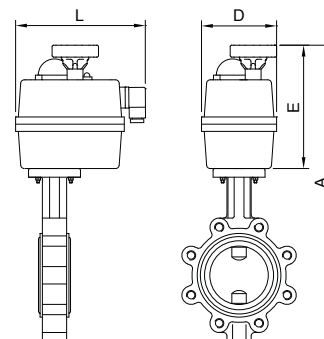

Información técnica
Technical information

Ref.5608



Válvula mariposa tipo LUG DIN

Características de la válvula ver artículo 2108. Servomotor trifásico (3-400 V). Otro voltaje consultar.

Butterfly valve DIN LUG type

Valve characteristics see article 2108. Triphasic servomotor (3-400 V). Other voltage please consult us.

MED.	A	E	L	D
5"	563	220	172	258
6"	627	259	229	338
8"	689	259	229	338
10"	799	288	244	357
12"	860	288	244	357

5608 13 58	5"	GE-010	17.85	1294,22
5608 14 59	6"	GE-015	29.35	1586,02
5608 16 55	8"	GE-025	33.9	1814,97
5608 18 56	10"	GE-035	49.55	2279,21
5608 20 62	12"	GE-050	76	2654,67

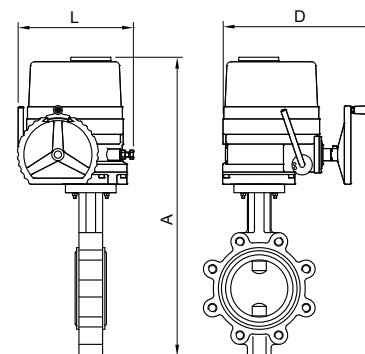

Información técnica
Technical information

Ref.5608A



Válvula mariposa tipo LUG ANSI

Características de la válvula ver artículo 2108A. Especificar tensión de alimentación necesaria.

Butterfly valve ANSI LUG type

Valve characteristics see article 2108A. Required voltage must be specified.

MED.	A	E	L	D
2"	436	196	181	110
2 1/2"	449	196	181	110
3"	464	196	181	110
4"	501	196	181	110
5"	539	196	181	110
6"	622	254	235	214
8"	684	254	235	214

5608A 09 52	2"	GE-1	6.7	595,38
5608A 10 52	2 1/2"	GE-1	7.3	609,17
5608A 11 52	3"	GE-1	7.3	651,43
5608A 12 48	4"	GE-15	11.5	834,66
5608A 13 48	5"	GE-15	13.3	1059,16
5608A 14 53	6"	GE-2	18.5	1208,14
5608A 16 54	8"	GE-2+	23.4	1583,41

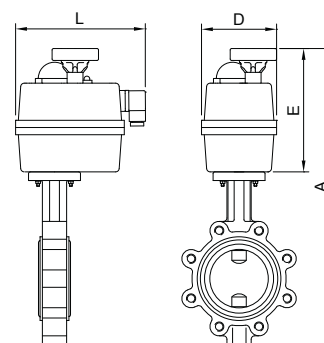

Información técnica
Technical information

Ref. 5608A



Válvula mariposa tipo LUG ANSI

Características de la válvula ver artículo 2108A. Servomotor trifásico (3-400 V). Otro voltaje consultar.

Butterfly valve ANSI LUG type

Valve characteristics see article 2108A. Triphasic servomotor (3-400 V). Other voltage please consult us.

MED.	A	E	L	D
5"	563	220	172	258
6"	627	259	229	338
8"	689	259	229	338
10"	799	288	244	357
12"	860	288	244	357
14"	891	313	287	380
16"	959	313	287	380
18"	1209	506	293	368
20"	1209	531	312	380

CÓDIGO CODE	MEDIDA SIZE	TIPO ACT. ACT. TYPE	PESO WEIGHT	P.V.P. € PRICE €
5608A 13 58	5"	GE-010	17.85	1433,69
5608A 14 59	6"	GE-015	29.35	1782,25
5608A 16 55	8"	GE-025	33.9	1830,66
5608A 18 56	10"	GE-035	49.55	2305,06
5608A 20 62	12"	GE-050	60	2713,08
5608A 22 57	14"	GE-080	97.5	4055,83
5608A 24 60	16"	GE-110	126.4	5298,25
5608A 26 64	18"	GE-150	208	7485,88
5608A 28 61	20"	GE-210	255	8885,37

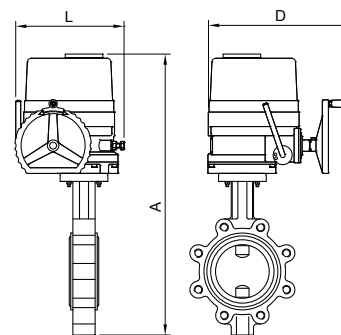

Información técnica
Technical information

Extensor para válvula automatizada - Actuador eléctrico

Extension for automated valve - electric actuator



Ref. 5334



Extensor para válvula automatizada (*)

(*) Válvula no incluida (consultar modelo de válvula)

Extension for automated valve (*)

(*) Valve not included (consult the model of the valve)

Válvulas roscar - soldar / Threaded - welded valves		
Ref.	ART.2015 - 2025 - 2026 - 2027	ART.2040 - 2041
5334 09 050	1/4" - 1/2"	1/4" - 1/2"
5334 11 050	3/4" - 1"	3/4" - 1"
5334 14 050	1 1/4" - 2"	1 1/4" - 2"
5334 17 050	2 1/2" - 4"	2 1/2"

Válvulas roscar - soldar / Threaded - welded valves		
Ref.	ART.2015 - 2025 - 2026 - 2027	ART.2040 - 2041
5334 14 100	1 1/4" - 2"	1 1/4" - 2"
5334 17 100	2 1/2" - 4"	2 1/2"

L = 50 mm				
5334 09 050	L=50 mm	0.46	-	77,34
5334 11 050	L= 50 mm	0.38	-	77,34
5334 14 050	L=50 mm	0.457	-	85,75
5334 17 050	L=50 mm	0.7	-	100,23
L = 100 mm				
5334 14 100	L= 100mm	0.84	-	111,99
5334 17 100	L= 100mm	1.116	-	134,09

Válvulas bridadas / Flanged valves			
Ref.	ART.2118 - 2119 - 2525	ART.2526A - 2528 - 2528A - 2529	ART.2540E - 2541E - 2544 - 2545
5334 09 050	1/2" - 3/4"	1/2"	*****
5334 11 050	1" - 1 1/4"	3/4" - 1"	1"
5334 14 100	1 1/2" - 2"	1 1/4" - 2"	1 1/4" - 2"
5334 17 100	2 1/2" - 4"	2 1/2" - 4"	2 1/2" - 4"



Información técnica
Technical information

04.



FITTING INOXIDABLES

Stainless Steel Fittings

Toda nuestra gama en: 1. Fitting inoxidable Clase 150 que cumple la Norma ISO 4144, en lo que respecta a la gama básica, dimensiones, espesores y pesos. 2. Fitting Camlock 3. Rácores en bicono acero inoxidable

All our range in: 1. Stainless steel fitting, 150 class in compliance with ISO 4144, regarding the basic range, measurements, thicknesses and weights. 2. Camlock fittings. 3. Stainless steel compression fitting

Fittings inoxidables / Stainless steel fittings

p. 140

Racord Camlock AISI 316 / Camlock fitting AISI 316

p. 145

Rácores con bicono en acero inoxidable 316 /
316 stainless steel compression fittings

p. 147

FITTING INOXIDABLE CLASE 150 / STAINLESS STEEL FITTING, 150 CLASS

Ref. 0090 - 0090N



Codo 90° H-H

También disponible con rosca NPT (Ref. 0090N).

90° elbow F-F

Also available with NPT thread (Ref. 0090N).

Med (R)	A
1/4"	19
3/8"	23
1/2"	27
3/4"	32
1"	38
1 1/4"	45
1 1/2"	48
2"	57
2 1/2"	69
3"	78
4"	96

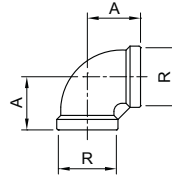

CÓDIGO CODE	MEDIDA SIZE	UNID. BOLSA UNIT BAG	P.V.P. € PRICE €
0090 02	1/4"	15	2,38
0090 03	3/8"	15	3,12
0090 04	1/2"	15	3,68
0090 05	3/4"	20	5,51
0090 06	1"	15	7,49
0090 07	1 1/4"	5	11,86
0090 08	1 1/2"	5	14,99
0090 09	2"	4	23,23
0090 10	2 1/2"	1	42,51
0090 11	3"	1	58,20
0090 12	4"	1	115,90

Precios rosca NPT a consultar / NPT thread prices on request



Información técnica
Technical information

Ref. 0092 - 0092N



Codo 90° M-H

También disponible con rosca NPT (Ref. 0092N).

90° elbow M-F

Also available with NPT thread (Ref. 0092N).

Med (R)	A	B
1/4"	19	27
3/8"	23	29
1/2"	27	35
3/4"	32	40
1"	38	46
1 1/4"	45	54
1 1/2"	48	57
2"	57	70
2 1/2"	69	83
3"	78	94
4"	96	115

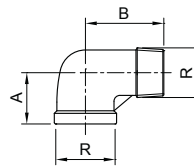

0092 02	1/4"	10	3,47
0092 03	3/8"	10	3,61
0092 04	1/2"	15	4,39
0092 05	3/4"	10	5,95
0092 06	1"	10	9,13
0092 07	1 1/4"	5	15,97
0092 08	1 1/2"	5	20,20
0092 09	2"	2	30,69
0092 10	2 1/2"	1	54,69
0092 11	3"	1	74,32
0092 12	4"	1	132,70

Precios rosca NPT a consultar / NPT thread prices on request



Información técnica
Technical information

Ref. 0120 - 0120N



Codo 45° H-H

También disponible con rosca NPT (Ref. 0120N).

45° elbow F-F

Also available with NPT thread (Ref. 0120N).

Med (R)	A
1/4"	17
3/8"	19
1/2"	21
3/4"	25
1"	29
1 1/4"	33
1 1/2"	37
2"	42
2 1/2"	49

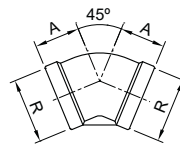

0120 02	1/4"	5	3,31
0120 03	3/8"	5	3,62
0120 04	1/2"	15	4,08
0120 05	3/4"	10	5,60
0120 06	1"	10	7,62
0120 07	1 1/4"	5	12,32
0120 08	1 1/2"	5	16,21
0120 09	2"	2	22,10
0120 10	2 1/2"	1	42,75

Precios rosca NPT a consultar / NPT thread prices on request



Información técnica
Technical information

Ref. 0130 - 0130N



Te igual H

También disponible con rosca NPT (Ref. 0130N).

Equal tee F

Also available with NPT thread (Ref. 0130N).

Med (R)	A
1/4"	19
3/8"	23
1/2"	27
3/4"	32
1"	38
1 1/4"	45
1 1/2"	48
2"	57
2 1/2"	69
3"	78
4"	96

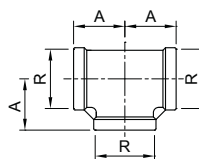

0130 02	1/4"	10	3,70
0130 03	3/8"	10	4,90
0130 04	1/2"	25	4,96
0130 05	3/4"	20	6,73
0130 06	1"	15	9,75
0130 07	1 1/4"	5	15,88
0130 08	1 1/2"	5	18,76
0130 09	2"	4	29,04
0130 10	2 1/2"	1	64,45
0130 11	3"	1	88,04
0130 12	4"	1	156,75

Precios rosca NPT a consultar / NPT thread prices on request



Información técnica
Technical information

FITTING INOXIDABLE CLASE 150 / STAINLESS STEEL FITTING, 150 CLASS

Ref.0149



Entronque soldar-M
Welding-M nipple

Med (R)	B	E	L
1/4"	13,7	2,24	30
3/8"	17,1	2,31	30
1/2"	21,3	2,77	35
3/4"	26,7	2,87	40
1"	33,4	3,38	40
1 1/4"	42,2	3,56	50
1 1/2"	48,3	3,68	50
2"	60,3	3,91	50
2 1/2"	76,1	5,16	60
3"	88,9	5,49	70
4"	114,3	6,02	80

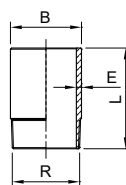

CÓDIGO CODE	MEDIDA SIZE	UNID. BOLSA UNIT BAG	P.V.P. € PRICE €
0149 02	1/4"	10	1,81
0149 03	3/8"	10	1,94
0149 04	1/2"	25	3,35
0149 05	3/4"	20	4,17
0149 06	1"	10	5,50
0149 07	1 1/4"	5	7,88
0149 08	1 1/2"	5	9,39
0149 09	2"	2	12,07
0149 10	2 1/2"	1	22,15
0149 11	3"	1	33,41
0149 12	4"	1	51,07



Información técnica
Technical information

Ref.0150



Entronque macho-macho
Long nipple male-male

Med (R)	B	E	L
1/4"	13,7	2,24	40
3/8"	17,1	2,31	40
1/2"	21,3	2,77	60
3/4"	26,7	2,87	60
1"	33,4	3,38	60
1 1/4"	42,2	3,56	80
1 1/2"	48,3	3,68	80
2"	60,3	3,91	100
2 1/2"	76,1	5,16	100
3"	88,9	5,49	120
4"	114,3	6,02	150

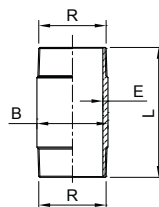

0150 02 040	1/4"	5	2,58
0150 03 040	3/8"	5	2,88
0150 04 060	1/2"	10	4,87
0150 05 060	3/4"	10	5,80
0150 06 060	1"	10	8,01
0150 07 080	1 1/4"	5	12,73
0150 08 080	1 1/2"	5	16,93
0150 09 100	2"	2	22,75
0150 10 100	2 1/2"	1	39,09
0150 11 120	3"	1	61,60
0150 12 150	4"	1	95,25



Información técnica
Technical information

Ref.0180 - 0180N



Cruz
También disponible con rosca NPT (Ref. 0180N).
Cross
Also available with NPT thread (Ref. 0180N).

Med (R)	A
1/4"	19
3/8"	23
1/2"	27
3/4"	32
1"	38
1 1/4"	45
1 1/2"	48
2"	57

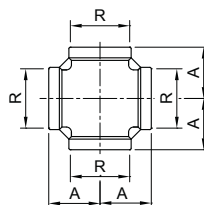

0180 02	1/4"	5	5,89
0180 03	3/8"	5	6,61
0180 04	1/2"	10	7,39
0180 05	3/4"	10	10,55
0180 06	1"	5	14,11
0180 07	1 1/4"	5	23,89
0180 08	1 1/2"	5	27,89
0180 09	2"	2	43,37

Precios rosca NPT a consultar / NPT thread prices on request



Información técnica
Technical information

Ref.0240 - 0240N



Manguito reducción
También disponible con rosca NPT (Ref. 0240N).
Reducing socket
Also available with NPT thread (Ref. 0240N).

Med (R1 x R2)	A
1/4" x 1/8"	25
3/8" x 1/4"	26
1/2" x 1/4"	34
1/2" x 3/8"	34
3/4" x 1/2"	36
1" x 3/4"	42
1 1/4" x 1"	48
1 1/2" x 1"	52
1 1/2" x 1 1/4"	52
2" x 1 1/2"	58
2 1/2" x 2"	60

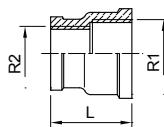

0240 02 01	1/4" x 1/8"	10	2,41
0240 03 02	3/8" x 1/4"	10	3,50
0240 04 02	1/2" x 1/4"	15	3,85
0240 04 03	1/2" x 3/8"	15	3,85
0240 05 04	3/4" x 1/2"	10	5,11
0240 06 05	1" x 3/4"	5	7,82
0240 07 06	1 1/4" x 1"	5	11,88
0240 08 06	1 1/2" x 1"	5	15,17
0240 08 07	1 1/2" x 1 1/4"	5	15,17
0240 09 08	2" x 1 1/2"	2	22,06
0240 10 09	2 1/2" x 2"	1	35,30

Precios rosca NPT a consultar / NPT thread prices on request



Información técnica
Technical information

FITTING INOXIDABLE CLASE 150 / STAINLESS STEEL FITTING, 150 CLASS

Ref. 0241 - 0241N



Reducción

También disponible con rosca NPT (Ref. 0241N).

Reducing socket

Also available with NPT thread (Ref. 0241N).

Med (R1 x R2)	L	S
1/4" x 1/8"	14,5	15
3/8" x 1/4"	16	18
1/2" x 1/4"	19,5	23
1/2" x 3/8"	19,5	23
3/4" x 3/8"	21	28
3/4" x 1/2"	21	28
1" x 1/2"	24	35
1" x 3/4"	24	35
1 1/4" x 3/4"	27	44
1 1/4" x 1"	27	44
1 1/2" x 1"	27	50
1 1/2" x 1 1/4"	27	50
2" x 1"	32	62
2" x 1 1/4"	32	62
2" x 1 1/2"	32	62
2 1/2" x 2"	34	77
3" x 2 1/2"	37,5	90

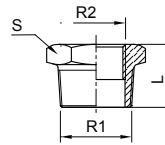

CÓDIGO CODE	MEDIDA SIZE	UNID. BOLSA UNIT BAG	P.V.P. € PRICE €
0241 02 01	1/4" x 1/8"	10	1,82
0241 03 02	3/8" x 1/4"	10	2,11
0241 04 02	1/2" x 1/4"	15	2,43
0241 04 03	1/2" x 3/8"	15	2,43
0241 05 03	3/4" x 3/8"	15	3,21
0241 05 04	3/4" x 1/2"	15	3,21
0241 06 04	1" x 1/2"	10	4,62
0241 06 05	1" x 3/4"	10	4,62
0241 07 05	1 1/4" x 3/4"	5	7,67
0241 07 06	1 1/4" x 1"	5	7,67
0241 08 06	1 1/2" x 1"	5	9,37
0241 08 07	1 1/2" x 1 1/4"	5	9,37
0241 09 06	2" x 1"	2	15,00
0241 09 07	2" x 1 1/4"	2	15,00
0241 09 08	2" x 1 1/2"	2	15,00
0241 10 09	2 1/2" x 2"	1	24,16
0241 11 10	3" x 2 1/2"	1	32,22

Precios rosca NPT a consultar / NPT thread prices on request



Información técnica
Technical information

Ref. 0245



Machón reducido

Reducing nipple

Med (R1 x R2)	L	S
1/4" x 1/8"	22,5	15
3/8" x 1/4"	26,5	18
1/2" x 1/4"	30	23
1/2" x 3/8"	30,5	23
3/4" x 1/2"	35,5	28
1" x 1/2"	38,5	35
1" x 3/4"	39,5	35
1 1/4" x 3/4"	42,5	44
1 1/4" x 1"	45	44
1 1/2" x 1"	45	50
1 1/2" x 1 1/4"	47,5	50
2" x 1 1/4"	52,5	62
2" x 1 1/2"	52,5	62

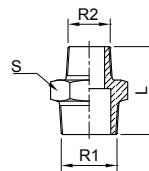

0245 02 01	1/4" x 1/8"	10	2,68
0245 03 02	3/8" x 1/4"	10	3,15
0245 04 02	1/2" x 1/4"	15	4,19
0245 04 03	1/2" x 3/8"	15	4,19
0245 05 04	3/4" x 1/2"	10	5,26
0245 06 04	1" x 1/2"	10	7,75
0245 06 05	1" x 3/4"	10	7,75
0245 07 05	1 1/4" x 3/4"	5	10,22
0245 07 06	1 1/4" x 1"	5	10,22
0245 08 06	1 1/2" x 1"	5	13,22
0245 08 07	1 1/2" x 1 1/4"	5	13,22
0245 09 07	2" x 1 1/4"	2	18,27
0245 09 08	2" x 1 1/2"	2	18,27



Información técnica
Technical information

Ref. 0270 - 0270N



Manguito liso H-H

También disponible con rosca NPT (Ref. 0270N).

Socket F-F

Also available with NPT thread (Ref. 0270N).

Med (R)	E	L
1/4"	16,5	24
3/8"	20	25
1/2"	24,5	32
3/4"	30	35
1"	37,5	41
1 1/4"	46,5	45
1 1/2"	53	45
2"	65,5	54
2 1/2"	82	63
3"	95,5	69

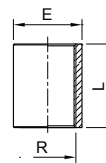

0270 02	1/4"	15	2,13
0270 03	3/8"	15	2,54
0270 04	1/2"	25	3,34
0270 05	3/4"	20	4,38
0270 06	1"	15	6,19
0270 07	1 1/4"	5	9,32
0270 08	1 1/2"	5	11,35
0270 09	2"	4	17,04
0270 10	2 1/2"	1	26,75
0270 11	3"	1	36,70

Precios rosca NPT a consultar / NPT thread prices on request



Información técnica
Technical information

Ref. 0280 - 0280N



Machón

También disponible con rosca NPT (Ref. 0280N).

Nipple

Also available with NPT thread (Ref. 0280N).

Med (R)	L	S
1/4"	25	15
3/8"	27	18
1/2"	34	23
3/4"	36,5	28
1"	42	35
1 1/4"	47,5	44
1 1/2"	47,5	50
2"	57	62
2 1/2"	61	77
3"	67,5	90

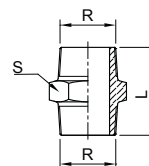

0280 02	1/4"	25	2,50
0280 03	3/8"	25	2,93
0280 04	1/2"	25	3,15
0280 05	3/4"	20	4,45
0280 06	1"	15	5,48
0280 07	1 1/4"	5	10,38
0280 08	1 1/2"	5	11,78
0280 09	2"	4	17,19
0280 10	2 1/2"	1	26,56
0280 11	3"	1	39,51

Precios rosca NPT a consultar / NPT thread prices on request



Información técnica
Technical information

FITTING INOXIDABLE CLASE 150 / STAINLESS STEEL FITTING, 150 CLASS

Ref.0285



Racor pasamuros

Rosca ISO 228/1.

Wall connector

ISO 228/1 thread.

Med (R)	L	S
3/8"	46	27
1/2"	57	32
3/4"	57	36
1"	69	46
1 1/4"	69	55
1 1/2"	70	60
2"	82	75

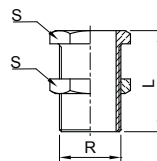

CÓDIGO CODE	MEDIDA SIZE	UNID. BOLSA UNIT BAG	P.V.P. € PRICE €
0285 03	3/8"	10	18,37
0285 04	1/2"	10	20,47
0285 05	3/4"	10	24,10
0285 06	1"	10	27,20
0285 07	1 1/4"	5	31,98
0285 08	1 1/2"	5	37,98
0285 09	2"	2	50,98



Información técnica
Technical information

Ref.0290 - 0290N



Tapón

También disponible con rosca NPT (Ref. 0290N).

Plug

Also available with NPT thread (Ref. 0290N).

Med (R)	L	S
1/4"	14,5	15
3/8"	16	18
1/2"	19,5	23
3/4"	21	28
1"	24	35
1 1/4"	27	44
1 1/2"	27	50
2"	32	62
2 1/2"	34	77
3"	37,5	90

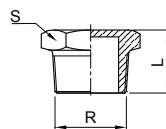

0290 02	1/4"	10	1,81
0290 03	3/8"	10	1,97
0290 04	1/2"	15	2,12
0290 05	3/4"	10	3,31
0290 06	1"	10	5,22
0290 07	1 1/4"	5	7,75
0290 08	1 1/2"	5	8,76
0290 09	2"	2	14,42
0290 10	2 1/2"	1	27,70
0290 11	3"	1	33,96

Precios rosca NPT a consultar / NPT thread prices on request



Información técnica
Technical information

Ref.0300 - 0300N



Tapa

También disponible con rosca NPT (Ref. 0300N).

Cap

Also available with NPT thread (Ref. 0300N).

Med (R)	L	S
1/4"	14	18
3/8"	14,5	20
1/2"	18,5	25
3/4"	19,5	30
1"	22,5	38
1 1/4"	25,5	47
1 1/2"	25,5	53
2"	30	66
2 1/2"	35	82
3"	38,5	96
4"	45	122

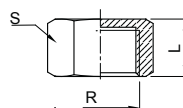

0300 02	1/4"	10	1,92
0300 03	3/8"	10	2,10
0300 04	1/2"	15	2,49
0300 05	3/4"	10	3,29
0300 06	1"	5	4,70
0300 07	1 1/4"	5	8,84
0300 08	1 1/2"	5	10,92
0300 09	2"	2	16,67
0300 10	2 1/2"	1	29,91
0300 11	3"	1	40,52
0300 12	4"	1	62,59

Precios rosca NPT a consultar / NPT thread prices on request



Información técnica
Technical information

Ref.0312



Tuerca

Nut

Med (R)	L	S
1/4"	7	18
3/8"	7	24
1/2"	8	30
3/4"	9	34
1"	9	43
1 1/4"	11	52
1 1/2"	12	58
2"	13	72

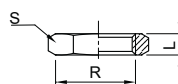

0312 02	1/4"	5	1,77
0312 03	3/8"	5	2,29
0312 04	1/2"	15	2,40
0312 05	3/4"	10	3,00
0312 06	1"	10	3,78
0312 07	1 1/4"	5	5,02
0312 08	1 1/2"	5	5,89
0312 09	2"	2	8,98



Información técnica
Technical information

FITTING INOXIDABLE CLASE 150 / STAINLESS STEEL FITTING, 150 CLASS

Ref. 0340 - 0340N



Enlace 3 piezas H-H

También disponible con rosca NPT (Ref. 0340N).

Union 3 piezas F-F

Also available with NPT thread (Ref. 0340N).

Med (R)	L	S1	S2
1/4"	33,5	17	29
3/8"	36,5	20	34
1/2"	39,5	25	39
3/4"	42,5	30	47
1"	50	38	58
1 1/4"	54	47	67
1 1/2"	58	53	76
2"	65	66	90
2 1/2"	75	82	109
3"	83	96	123

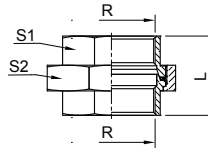

CÓDIGO CODE	MEDIDA SIZE	UNID. BOLSA UNIT BAG	P.V.P. € PRICE €
-------------	-------------	----------------------	------------------

0340 02	1/4"	5	8,99
0340 03	3/8"	5	10,61
0340 04	1/2"	15	11,22
0340 05	3/4"	10	13,15
0340 06	1"	10	19,81
0340 07	1 1/4"	5	30,39
0340 08	1 1/2"	5	39,31
0340 09	2"	2	51,05
0340 10	2 1/2"	1	85,62
0340 11	3"	1	106,59

Precios rosca NPT a consultar / NPT thread prices on request



Información técnica
Technical information

Ref. 0341 - 0341N



Enlace 3 piezas M-H

También disponible con rosca NPT (Ref. 0341N).

Union 3 piezas M-F

Also available with NPT thread (Ref. 0341N).

Med (R)	L	S1	S2
1/4"	44	17	29
3/8"	47,5	20	34
1/2"	54	25	39
3/4"	58	30	47
1"	68	38	58
1 1/4"	74,5	47	67
1 1/2"	78,5	53	76
2"	90	66	90
2 1/2"	102	82	109
3"	113	96	123

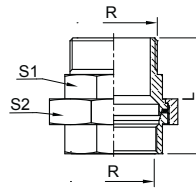

0341 02	1/4"	5	11,24
0341 03	3/8"	5	12,20
0341 04	1/2"	10	13,09
0341 05	3/4"	10	15,52
0341 06	1"	10	23,25
0341 07	1 1/4"	5	35,62
0341 08	1 1/2"	5	47,38
0341 09	2"	2	63,91
0341 10	2 1/2"	1	106,19
0341 11	3"	1	132,22

Precios rosca NPT a consultar / NPT thread prices on request



Información técnica
Technical information

Ref. 0399 - 0399N



Entronque manguera

También disponible con rosca NPT (Ref. 0399N).

Hose nipple

Also available with NPT thread (Ref. 0399N).

Med (R)	L	D	S
1/4"	42,5	9	15
3/8"	49	11,5	18
1/2"	57,5	15	22
3/4"	66	20	28
1"	76	27	35
1 1/4"	79	33	44
1 1/2"	83	39,5	50
2"	92	52	62
2 1/2"	99	67	78
3"	107,5	80	91

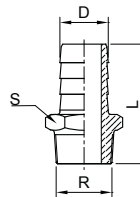

0399 02	1/4"	10	3,07
0399 03	3/8"	10	3,98
0399 04	1/2"	15	4,73
0399 05	3/4"	10	7,38
0399 06	1"	10	9,94
0399 07	1 1/4"	5	13,70
0399 08	1 1/2"	5	17,38
0399 09	2"	2	26,46
0399 10	2 1/2"	2	43,05
0399 11	3"	1	58,67

Precios rosca NPT a consultar / NPT thread prices on request



Información técnica
Technical information

RACORD CAMLOCK / CAMLOCK FITTING

Ref.0400



Racor Tipo A: Camlock Macho – Rosca Hembra ISO 7-1 (EN 10226-1).

Material AISI 316. Presión Máx. de trabajo: 10 bar (150 PSI).

Fitting Type A: Male Camlock - Female Thread ISO 7-1 (EN 10226-1).

Material AISI 316. Max. working pressure: 10 bar (150 psi).

Med (R)	D	L
1/2"	23,8	36
3/4"	32	35
1"	36,7	44
1 1/4"	45,5	51
1 1/2"	53,3	53
2"	63	60
2 1/2"	75,8	76
3"	91,5	67
4"	119,5	71

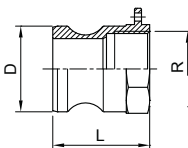

CÓDIGO CODE	MEDIDA SIZE	UNID. BOLSA UNIT BAG	P.V.P. € PRICE €
0400 04	1/2"	1	4,95
0400 05	3/4"	1	5,27
0400 06	1"	1	7,52
0400 07	1 1/4"	1	11,65
0400 08	1 1/2"	1	14,94
0400 09	2"	1	19,71
0400 10	2 1/2"	1	32,99
0400 11	3"	1	37,44
0400 12	4"	1	59,63



Información técnica
Technical information

Ref.0410



Racor Tipo B: Camlock Hembra – Rosca Macho ISO 7-1 (EN 10226-1).

Material AISI 316. Presión Máx. de trabajo: 10 bar (150 PSI). Junta NBR incluida.

Fitting Type B: Female Camlock - Male Thread ISO 7-1 (EN 10226-1).

Material AISI 316. Max. working pressure: 10 bar (150 psi). Included NBR gasket.

Med (R)	D	L
1/2"	24,3	44
3/4"	32,7	45
1"	37,7	54
1 1/4"	46	63
1 1/2"	54	67
2"	64	72
2 1/2"	76,8	84
3"	92,2	87
4"	120,5	89

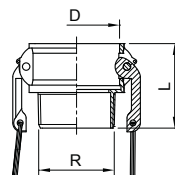

0410 04	1/2"	1	10,38
0410 05	3/4"	1	11,20
0410 06	1"	1	15,83
0410 07	1 1/4"	1	19,48
0410 08	1 1/2"	1	21,96
0410 09	2"	1	29,04
0410 10	2 1/2"	1	37,72
0410 11	3"	1	53,36
0410 12	4"	1	76,91



Información técnica
Technical information

Ref.0420



Racor Tipo C: Camlock Hembra – Espiga manguera

Material AISI 316. Presión Máx. de trabajo: 10 bar (150 PSI). Junta NBR incluida

Fitting Type C: Female Camlock - Hose connector

Material AISI 316. Max. working pressure: 10 bar (150 psi). Included NBR gasket.

Med.	D	L	d
1/2"	24,3	70	12
3/4"	32,7	80	19
1"	37,7	94	25
1 1/4"	46	105	32
1 1/2"	54	110	38,5
2"	64	125	50,5
2 1/2"	76,8	133	65
3"	92,2	144	76
4"	120,5	153	100,5

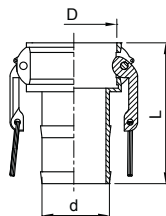

0420 04	1/2"	1	10,18
0420 05	3/4"	1	10,79
0420 06	1"	1	13,87
0420 07	1 1/4"	1	22,92
0420 08	1 1/2"	1	23,80
0420 09	2"	1	36,56
0420 10	2 1/2"	1	42,97
0420 11	3"	1	67,25
0420 12	4"	1	93,27



Información técnica
Technical information

Ref.0430



Racor Tipo D: Camlock Hembra – Rosca Hembra ISO 7-1 (EN 10226-1).

Material AISI 316. Presión Máx. de trabajo: 10 bar (150 PSI). Junta NBR incluida.

Fitting Type D: Female Camlock - Female Thread ISO 7-1 (EN 10226-1).

Material AISI 316. Max. working pressure: 10 bar (150 psi). Included NBR gasket.

Med (R)	D	L
1/2"	24,3	43
3/4"	32,7	44
1"	37,7	54
1 1/4"	46	64
1 1/2"	54	66
2"	64	73
2 1/2"	76,8	79
3"	92,2	82
4"	120,5	85

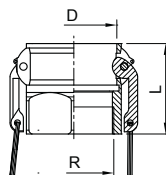

0430 04	1/2"	1	10,67
0430 05	3/4"	1	11,41
0430 06	1"	1	13,74
0430 07	1 1/4"	1	19,88
0430 08	1 1/2"	1	21,80
0430 09	2"	1	28,61
0430 10	2 1/2"	1	42,13
0430 11	3"	1	58,06
0430 12	4"	1	86,06



Información técnica
Technical information

RACORD CAMLOCK / CAMLOCK FITTING

Ref.0440



Racor Tipo E: Camlock Macho - Espiga manguera

Material AISI 316. Presión Máx. de trabajo: 10 bar (150 PSI)

Fitting Type E: Male Camlock - Hose connector

Material AISI 316. Max. working pressure: 10 bar (150 psi)

Med.	D	L	d
1/2"	23,8	73	12
3/4"	32	88	19
1"	36,	97	25
1 1/4"	45,5	113	32
1 1/2"	53,5	118	38,5
2"	63	136	50,5
2 1/2"	75,8	140	65
3"	91,5	153	76
4"	119,5	162	100,5

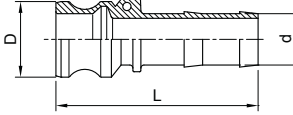

CÓDIGO CODE	MEDIDA SIZE	UNID. BOLSA UNIT BAG	P.V.P. € PRICE €
0440 04	1/2"	1	5,65
0440 05	3/4"	1	6,08
0440 06	1"	1	8,86
0440 07	1 1/4"	1	13,49
0440 08	1 1/2"	1	16,46
0440 09	2"	1	26,18
0440 10	2 1/2"	1	35,95
0440 11	3"	1	52,30
0440 12	4"	1	87,63



Información técnica
Technical information

Ref.0450



Racor Tipo F: Camlock Macho - Rosca Macho ISO 7-1 (EN 10226-1).

Material AISI 316. Presión Máx. de trabajo: 10 bar (150 PSI).

Fitting Type F: Male Camlock - Male Thread ISO 7-1 (EN 10226-1).

Material AISI 316. Max. working pressure: 10 bar (150 psi).

Med (R)	D	L
1/2"	23,8	49
3/4"	32	50
1"	36,7	62
1 1/4"	45,5	71
1 1/2"	53,3	74
2"	63	84
2 1/2"	75,8	89
3"	91,5	92
4"	119,5	102

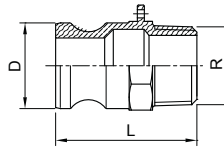

0450 04	1/2"	1	5,70
0450 05	3/4"	1	5,97
0450 06	1"	1	8,57
0450 07	1 1/4"	1	12,22
0450 08	1 1/2"	1	16,99
0450 09	2"	1	24,60
0450 10	2 1/2"	1	35,96
0450 11	3"	1	53,11
0450 12	4"	1	74,22



Información técnica
Technical information

Ref.0460



Racor Tipo DC: Tapón Camlock Hembra

Material AISI 316. Presión Máx. de trabajo: 10 bar (150 PSI). Junta NBR incluida

Fitting Type DC: Female Camlock Plug.

Material AISI 316. Max. Working pressure: 10 bar (150 psi). Included NBR gasket.

Med.	D	L
1/2"	24,3	37
3/4"	32,7	44
1"	37,7	50
1 1/4"	46	59
1 1/2"	54	59
2"	64	66
2 1/2"	76,8	66
3"	92,2	71
4"	120,5	75

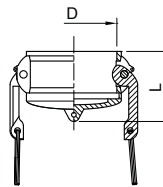

0460 04	1/2"	1	9,50
0460 05	3/4"	1	10,11
0460 06	1"	1	11,96
0460 07	1 1/4"	1	18,71
0460 08	1 1/2"	1	20,71
0460 09	2"	1	27,13
0460 10	2 1/2"	1	31,20
0460 11	3"	1	47,20
0460 12	4"	1	62,74



Información técnica
Technical information

Ref.0470



Racor Tipo DP: Tapón Camlock Macho

Material AISI 316. Presión Máx. de trabajo: 10 bar (150 PSI).

Fitting Type DP: Male Camlock Plug

Material AISI 316. Max. Working pressure: 10 bar (150 psi).

Med.	D	L
1/2"	23,8	35
3/4"	32	38
1"	36,7	43
1 1/4"	45,5	55
1 1/2"	53,3	55
2"	63	62
2 1/2"	75,8	62
3"	91,5	62
4"	119,5	65

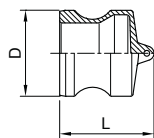

0470 04	1/2"	1	3,87
0470 05	3/4"	1	3,87
0470 06	1"	1	5,85
0470 07	1 1/4"	1	7,43
0470 08	1 1/2"	-	10,50
0470 09	2"	1	17,58
0470 10	2 1/2"	1	23,46
0470 11	3"	1	31,46
0470 12	4"	1	45,56



Información técnica
Technical information

Ref.0480



Junta para Racord Camlock

Material NBR

Camlock gasket.

Material NBR

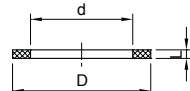

Med.	D	d	L
1/2"	26,3	16	4
3/4"	34,9	22,2	5,4
1"	39,7	27	6,3
1 1/4"	49,2	34,5	6,3
1 1/2"	55,6	41,3	6,3
2"	66,7	50,8	6,3
2 1/2"	79,4	60,3	6,3
3"	94,4	76,2	6,3
4"	123,8	101,6	6,3

0480 04	1/2"	1	0,20
0480 05	3/4"	1	0,31
0480 06	1"	1	0,38
0480 07	1 1/4"	1	0,50
0480 08	1 1/2"	1	0,64
0480 09	2"	1	0,76
0480 10	2 1/2"	1	1,01
0480 11	3"	1	1,20
0480 12	4"	1	1,78



Información técnica
Technical information

RACORES CON BICONO ACERO INOXIDABLE / STAINLESS STEEL COMPRESSION FITTING

Ref.8401

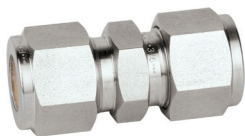

Unión Tubo - Tubo (pulgada)

Material AISI 316.
Presión máx. de trabajo: 315 bar.

Union Tube - Tube (inch)

Material AISI 316.
Max. working pressure: 315 bar.

CÓDIGO CODE	MEDIDA SIZE	UNID. BOLSA UNIT BAG	P.V.P. € PRICE €
8401 02 02	1/4" x 1/4"	5	21,63
8401 03 02	3/8" x 1/4"	5	28,76
8401 03 03	3/8" x 3/8"	5	30,70
8401 04 02	1/2" x 1/4"	-	33,51
8401 04 03	1/2" x 3/8"	3	34,94
8401 04 04	1/2" x 1/2"	3	40,13



Información técnica
Technical information

Ref.8401D

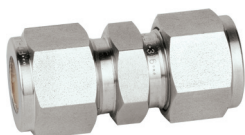

Unión Tubo - Tubo (mm)

Material AISI 316.
Presión máx. de trabajo: 315 bar.

Union Tube - Tube (mm)

Material AISI 316.
Max. working pressure: 315 bar.

8401D 006 006	6 x 6	5	21,63
8401D 008 006	8 x 6	5	25,00
8401D 008 008	8 x 8	5	24,09
8401D 010 008	10 x 8	-	30,50
8401D 010 006	10 x 6	-	29,26
8401D 010 010	10 x 10	-	31,19
8401D 012 006	12 x 6	3	33,36
8401D 012 008	12 x 8	3	34,57
8401D 012 010	12 x 10	-	37,23
8401D 012 012	12 x 12	3	40,13



Información técnica
Technical information

Ref.8402



Codo Tubo - Tubo (pulgada)

Material AISI 316.
Presión máx. de trabajo: 315 bar.

Elbow Tube - Tube (inch)

Material AISI 316.
Max. working pressure: 315 bar.

8402 02 02	1/4" x 1/4"	4	27,25
8402 03 03	3/8" x 3/8"	2	42,60
8402 04 04	1/2" x 1/2"	1	54,45



Información técnica
Technical information

Ref.8402D



Codo Tubo - Tubo (mm)

Material AISI 316.
Presión máx. de trabajo: 315 bar.

Elbow Tube - Tube (mm)

Material AISI 316.
Max. working pressure: 315 bar.

8402D 006 006	6 x 6	4	27,22
8402D 008 008	8 x 8	2	32,09
8402D 010 010	10 x 10	-	42,67
8402D 012 012	12 x 12	1	54,42



Información técnica
Technical information

RACORES CON BICONO ACERO INOXIDABLE / STAINLESS STEEL COMPRESSION FITTING

Ref.8403

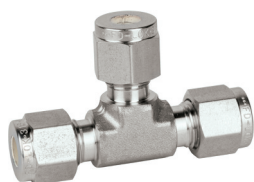

Te Tubo - Tubo (pulgada)

Material AISI 316.
Presión máx. de trabajo: 315 bar.

Tee Tube - Tube (inch)

Material AISI 316.
Max. working pressure: 315 bar.

CÓDIGO CODE	MEDIDA SIZE	UNID. BOLSA UNIT BAG	P.V.P. € PRICE €
8403 02 02	1/4" x 1/4"	1	44,54
8403 03 03	3/8" x 3/8"	1	57,96
8403 04 04	1/2" x 1/2"	1	76,79



Información técnica
Technical information

Ref.8403D



Te Tubo - Tubo (mm)

Material AISI 316.
Presión máx. de trabajo: 315 bar.

Tee Tube - Tube (mm)

Material AISI 316.
Max. working pressure: 315 bar.

8403D 006 006	6 x 6	1	44,51
8403D 008 008	8 x 8	1	48,13
8403D 010 010	10 x 10	-	60,32
8403D 012 012	12 x 12	1	73,96



Información técnica
Technical information

Ref.8404

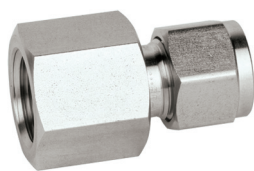

Conector Rosca H (BSPP) - Tubo (pulgada)

Material AISI 316. Rosca: ISO 7-1 Rp
Presión máx. de trabajo: 315 bar.

Connector Thread F (BSPP) - Tube (inch)

Material AISI 316. Thread: ISO 7-1 Rp
Max. working pressure: 315 bar.

8404 02 02	1/4" x 1/4"	4	17,13
8404 03 02	3/8" x 1/4"	3	20,97
8404 03 03	3/8" x 3/8"	3	29,34
8404 04 02	1/2" x 1/4"	1	30,06
8404 04 03	1/2" x 3/8"	1	34,91
8404 04 04	1/2" x 1/2"	1	38,41



Información técnica
Technical information

Ref.8404N

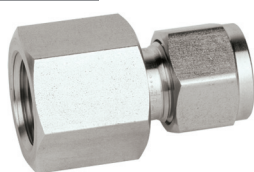

Conector Rosca H (NPT) - Tubo (pulgada)

Material AISI 316. Rosca: NPT ASME B 1.20.1.
Presión máx. de trabajo: 315 bar.

Connector Thread F (NPT) - Tube (inch)

Material AISI 316. Thread: NPT ASME B 1.20.1.
Max. working pressure: 315 bar.

8404N 02 02	1/4" x 1/4"	4	17,13
8404N 03 02	3/8" x 1/4"	3	20,97
8404N 03 03	3/8" x 3/8"	3	29,34
8404N 04 02	1/2" x 1/4"	1	30,06
8404N 04 03	1/2" x 3/8"	1	34,91
8404N 04 04	1/2" x 1/2"	1	38,41



Información técnica
Technical information

Ref.8404D

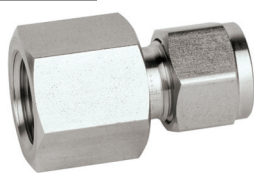

Conector Rosca H (BSPP) - Tubo (mm)

Material AISI 316. Rosca: ISO 7-1 Rp
Presión máx. de trabajo: 315 bar.

Connector Thread F (BSPP) - Tube (mm)

Material AISI 316. Thread: ISO 7-1 Rp
Max. working pressure: 315 bar.

8404D 02 006	1/4" x 6	4	17,13
8404D 03 006	3/8" x 6	3	30,01
8404D 03 008	3/8" x 8	3	28,76
8404D 03 010	3/8" x 10	-	29,78
8404D 04 006	1/2" x 6	1	30,01
8404D 04 008	1/2" x 8	1	31,40
8404D 04 012	1/2" x 12	1	37,68



Información técnica
Technical information

RACORES CON BICONO ACERO INOXIDABLE / STAINLESS STEEL COMPRESSION FITTING

Ref.8404ND

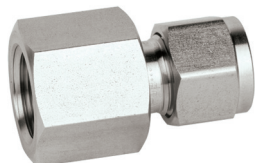

Conector Rosca H (NPT) - Tubo (mm)

Material AISI 316. Rosca: NPT ASME B 1.20.1.
Presión máx. de trabajo: 315 bar.

Connector Thread F (NPT) - Tube (mm)

Material AISI 316. Thread: NPT ASME B 1.20.1.
Max. working pressure: 315 bar.

CÓDIGO CODE	MEDIDA SIZE	UNID. BOLSA UNIT BAG	P.V.P. € PRICE €
8404ND 02 006	1/4" x 6	4	17,13
8404ND 03 006	3/8" x 6	3	30,01
8404ND 03 008	3/8" x 8	3	24,44
8404ND 03 010	3/8" x 10	-	29,78
8404ND 04 006	1/2" x 6	1	30,01
8404ND 04 008	1/2" x 8	1	31,40
8404ND 04 012	1/2" x 12	1	37,68



Información técnica
Technical information

Ref.8405

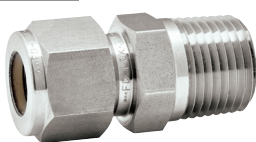

Conector Rosca M (BSPT) - Tubo (pulgada)

Material AISI 316. Rosca: ISO 7-1 R
Presión máx. de trabajo: 315 bar.

Connector Thread M (BSPT) - Tube (inch)

Material AISI 316. Thread: ISO 7-1 R
Max. working pressure: 315 bar.

8405 02 02	1/4" x 1/4"	5	14,36
8405 03 02	3/8" x 1/4"	5	16,12
8405 03 03	3/8" x 3/8"	5	19,94
8405 04 02	1/2" x 1/4"	3	21,03
8405 04 03	1/2" x 3/8"	3	25,30
8405 04 04	1/2" x 1/2"	3	27,25



Información técnica
Technical information

Ref.8405N

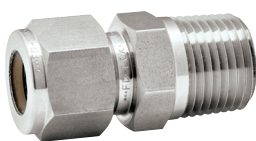

Conector Rosca M (NPT) - Tubo (pulgada)

Material AISI 316. Rosca: NPT ASME B 1.20.1.
Presión máx. de trabajo: 315 bar.

Connector Thread M (NPT) - Tube (inch)

Material AISI 316. Thread: NPT ASME B 1.20.1.
Max. working pressure: 315 bar.

8405N 02 02	1/4" x 1/4"	5	14,36
8405N 03 02	3/8" x 1/4"	5	16,12
8405N 03 03	3/8" x 3/8"	5	19,94
8405N 04 02	1/2" x 1/4"	3	21,03
8405N 04 03	1/2" x 3/8"	3	25,30
8405N 04 04	1/2" x 1/2"	3	27,25



Información técnica
Technical information

Ref.8405D

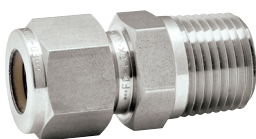

Conector Rosca M (BSPT) - Tubo (mm)

Material AISI 316. Rosca: ISO 7-1 R
Presión máx. de trabajo: 315 bar.

Connector Thread M (BSPT) - Tube (mm)

Material AISI 316. Thread: ISO 7-1 R
Max. working pressure: 315 bar.

8405D 02 006	1/4" x 6	5	14,32
8405D 03 006	3/8" x 6	5	16,22
8405D 03 008	3/8" x 8	5	17,48
8405D 03 010	3/8" x 10	-	21,65
8405D 04 010	1/2" x 10	-	23,84
8405D 04 006	1/2" x 6	3	20,94
8405D 04 008	1/2" x 8	3	23,46
8405D 04 012	1/2" x 12	3	27,22



Información técnica
Technical information

Ref.8405ND

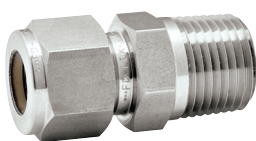

Conector Rosca M (NPT) - Tubo (mm)

Material AISI 316. Rosca: NPT ASME B 1.20.1.
Presión máx. de trabajo: 315 bar.

Connector Thread M (NPT) - Tube (mm)

Material AISI 316. Thread: NPT ASME B 1.20.1.
Max. working pressure: 315 bar.

8405ND 02 006	1/4" x 6	5	14,32
8405ND 03 006	3/8" x 6	5	16,22
8405ND 03 008	3/8" x 8	5	17,48
8405ND 03 010	3/8" x 10	-	21,65
8405ND 04 006	1/2" x 6	3	20,94
8405ND 04 008	1/2" x 8	3	23,46
8405ND 04 010	1/2" x 10	-	23,84
8405ND 04 012	1/2" x 12	3	27,22



Información técnica
Technical information

RACORES CON BICONO ACERO INOXIDABLE / STAINLESS STEEL COMPRESSION FITTING

Ref.8406



Codo Rosca M (BSPT) - Tubo (pulgada)

Material AISI 316. Rosca: ISO 7-1 R
Presión máx. de trabajo: 315 bar.

Elbow Thread M (BSPT) - Tube (inch)

Material AISI 316. Thread: ISO 7-1 R
Max. working pressure: 315 bar.



 **Información técnica**
Technical information

CÓDIGO CODE	MEDIDA SIZE	UNID. BOLSA UNIT BAG	P.V.P. € PRICE €
8406 02 02	1/4" x 1/4"	4	20,76
8406 03 02	3/8" x 1/4"	2	26,68
8406 03 03	3/8" x 3/8"	2	30,28
8406 04 02	1/2" x 1/4"	1	38,41
8406 04 03	1/2" x 3/8"	1	40,13
8406 04 04	1/2" x 1/2"	1	43,69

Ref.8406N



Codo Rosca M (NPT) - Tubo (pulgada)

Material AISI 316. Rosca: NPT ASME B 1.20.1.
Presión máx. de trabajo: 315 bar.

Elbow Thread M (NPT) - Tube (inch)

Material AISI 316. Thread: NPT ASME B 1.20.1.
Max. working pressure: 315 bar.



 **Información técnica**
Technical information

8406N 02 02	1/4" x 1/4"	4	20,76
8406N 03 02	3/8" x 1/4"	2	26,68
8406N 03 03	3/8" x 3/8"	2	30,28
8406N 04 02	1/2" x 1/4"	1	38,41
8406N 04 03	1/2" x 3/8"	1	40,13
8406N 04 04	1/2" x 1/2"	1	43,69

Ref.8406D



Codo Rosca M (BSPT) - Tubo (mm)

Material AISI 316. Rosca: ISO 7-1 R
Presión máx. de trabajo: 315 bar.

Elbow Thread M (BSPT) - Tube (mm)

Material AISI 316. Thread: ISO 7-1 R
Max. working pressure: 315 bar.



 **Información técnica**
Technical information

8406D 02 006	1/4" x 6	4	18,17
8406D 03 006	3/8" x 6	2	26,68
8406D 03 008	3/8" x 8	2	27,94
8406D 03 010	3/8" x 10	-	30,71
8406D 04 006	1/2" x 6	1	36,64
8406D 04 008	1/2" x 8	1	36,64
8406D 04 010	1/2" x 10	-	40,78
8406D 04 012	1/2" x 12	1	43,60

Ref.8406ND



Codo Rosca M (NPT) - Tubo (mm)

Material AISI 316. Rosca: NPT ASME B 1.20.1.
Presión máx. de trabajo: 315 bar.

Elbow Thread M (NPT) - Tube (mm)

Material AISI 316. Thread: NPT ASME B 1.20.1.
Max. working pressure: 315 bar.



 **Información técnica**
Technical information

8406ND 02 006	1/4" x 6	4	18,17
8406ND 03 006	3/8" x 6	2	26,68
8406ND 03 008	3/8" x 8	2	27,94
8406ND 03 010	3/8" x 10	-	30,71
8406ND 04 006	1/2" x 6	1	36,64
8406ND 04 008	1/2" x 8	1	36,64
8406ND 04 010	1/2"	-	40,78
8406ND 04 012	1/2" x 12	1	43,60



GENEBRE
PARTNER IN FLUID CONTROL SOLUTIONS

05.



INSTRUMENTACIÓN INDUSTRIAL

Industrial Instrumentation

Aparatos y equipos para la medida, control, supervisión y regulación de procesos industriales.

Devices and equipment for the measurement, control, monitoring and regulation of industrial processes

Manómetros / Pressure gauges	p. 155
Termómetros / Thermometer	p. 156
Sondas / Probes	p. 158
Convertidores / Indicators	p. 159
Reguladores / Regulators	p. 159
Transmisores de presión / Pressure transmitters	p. 159

Ref.8011



Manómetro (vacuómetro)
 D = 100 acero inoxidable 304, aro: bayoneta.
 Aguja: micrométrica.
 Doble escala: psi/bar.
 Entrada inferior 1/2".
 Clase: 1,0.
 Visor cristal laminado.
 Opcional con glicerina.

Pressure gauge (vacuometer)
 D = 100 stainless steel 304, ring: bayonet.
 Needle: micrometer.
 Double scale: psi/bar.
 Bottom entry 1/2".
 Class: 1,0.
 Glass laminate sight.
 Available optional with glycerine.

CÓDIGO CODE	ESCALA SCALE	CAJA / BOX CARTON	P.V.P. € PRICE €
8011 01	-1 +0 bar	1-44	85,21
8011 103	-1 +3 bar	1-44	85,21



Información técnica
 Technical information

Ref.8012



Manómetro
 D = 100 acero inoxidable 304, aro: bayoneta.
 Aguja: micrométrica.
 Doble escala: psi/bar.
 Entrada inferior 1/2".
 Clase: 1,0.
 Visor cristal laminado.
 Opcional con glicerina.

Pressure gauge
 D = 100 stainless steel 304, ring: bayonet.
 Needle: micrometer.
 Double scale: psi/ bar.
 Bottom entry 1/2".
 Class: 1,0.
 Glass laminate sight.
 Available optional with glycerine.

8012 001	0 +1 bar	1-25	78,72
8012 002	0 +2 bar	1-25	78,72
8012 006	0 +6 bar	1-25	78,72
8012 010	0 +10 bar	1-25	78,72
8012 016	0 +16 bar	1-25	78,72
8012 025	0 +25 bar	1-25	78,72
8012 060	0 +60 bar	1-25	78,72
8012 100	0 +100 bar	1-25	78,72
8012 250	0 +250 bar	1-25	78,72
8012 600	0 +600 bar	1-25	78,72



Información técnica
 Technical information

Ref.8020



Válvula porta manómetro
 PN10. Construcción en latón UNE-EN 12165. Conexión roscada M-H según ISO 228/1. Con orificio de purga. Mando manual de latón con funda termoplástica.

Gauge valve
 PN10. Brass construction UNE-EN 12165. Threaded ends ISO 228/1 M-F. With purge orifice. Brass lever manual control with thermoplastic sleeve.

R	L	L1	H	H1
1/4"	51	10	64	50
1/2"	56,6	12	68,5	54,7

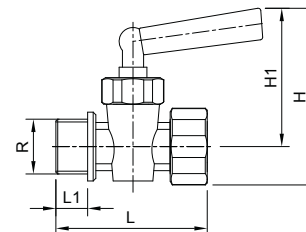

Información técnica
 Technical information

Ref.8021



Válvula porta manómetro con pletina de control
 PN10. Construcción en latón UNE-EN 12165. Conexión roscada M-H según ISO 228/1. Con orificio de purga. Con pletina de control para verificación del manómetro. Mando manual de latón con funda termoplástica.

Gauge valve with test flange
 PN10. Brass construction UNE-EN 12165. Threaded ends ISO 228/1 M-F. With purge orifice. With test flange for pressure gauge control. Brass lever manual control with thermoplastic sleeve.

R	L	L1	H	H1	D
1/4"	59	10	64	50	40
1/2"	69	14	72	54,7	40

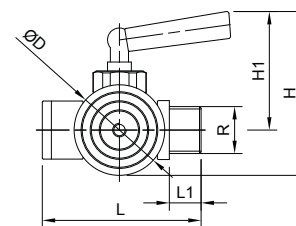

Información técnica
 Technical information

CÓDIGO CODE	MEDIDA SIZE	PESO WEIGHT	CAJA / BOX CARTON	P.V.P. € PRICE €
8020 02	1/4"	0.16	15-90	14,51
8020 04	1/2"	0.175	15-90	16,13

8021 02	1/4"	0.21	10-60	17,34
8021 04	1/2"	0.25	13-78	20,16

CÓDIGO CODE	MEDIDA SIZE	PESO WEIGHT	CAJA / BOX CARTON	P.V.P. € PRICE €
----------------	----------------	----------------	----------------------	---------------------

Ref.8028



Separador térmico tipo lira

PN25. Construcción en cobre UNE-EN 1057 y extremos de latón UNE-EN 12165. Conexión roscada M-H según ISO 228/1

Thermal divider lyre type

PN25. Copper tube UNE-EN 1057 and brass connections UNE-EN 12165. Threaded ends ISO 228/1 M-F

R	D1	D	H
1/4"	8	64	178
1/2"	8	64	178

8028 02	1/4"	0.08	20-120	11,29
8028 04	1/2"	0.12	15-90	13,10

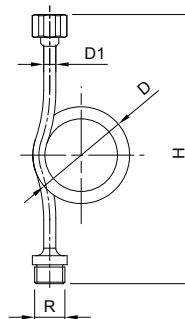

Información técnica
Technical information

Ref.8029



Separador térmico tipo lira

Material acero inoxidable AISI 316. Empalme macho-hembra. 1/2"G.

Thermal divider lyre type

Material: stainless steel AISI316. Connection male-female 1/2"G.

R	D1	D	H
1/2"	10	70	204

8029 04	-	0.315	1-31	60,15
---------	---	-------	------	-------

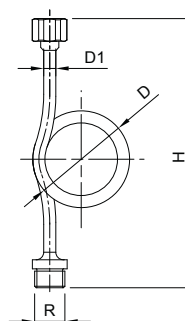

Información técnica
Technical information

Ref.8032 - 8034



Termómetros bimetalicos 63 mm 8032 (posterior L: 50mm) / 8034 (posterior L: 100mm)

Material de la vaina: Latón. Dimensiones de la caja: 63 mm. Material: acero cincado y plateado. Visor: Cristal. Longitud bulbo Ref: 8032 (L): 50 mm. 8034 (L): 100 mm. Escala: Doble escala °C & °F. Precisión: ±2.5%. Rosca 1/2"G.

Bimetallic thermometer 63 mm 8032 (back entry L: 50mm) / 8034 (back entry L: 100mm)

Stem material: brass. Box dimensions: 63 mm. Material: zinc iron plated. Sight: Glass. Stem length Ref: 8032 (L): 50 mm. 8034 (L): 100 mm. Double escale °C & °F. Precision: ±2.5%. Thread 1/2"G.

8032 206	-20 +60 °C	1-60	10,64
8032 060	0 +60 °C	1-60	10,64
8032 120	0 +120 °C	1-60	10,64
8034 206	-20 +60 °C	1-30	13,15
8034 060	0 +60 °C	1-30	13,15
8034 120	0 +120 °C	1-30	13,15



Información técnica
Technical information

Ref.8033 - 8035

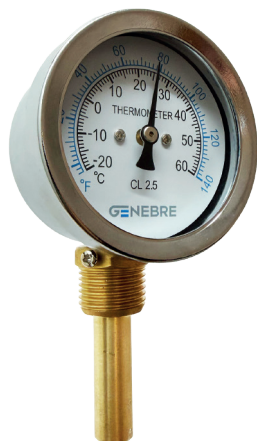

Termómetros bimetalicos 63 mm 8033 (inferior L: 50mm) / 8035 (inferior L: 100mm)

Material de la vaina: Latón. Dimensiones de la caja: 63 mm. Material: acero cincado y plateado. Visor: Cristal. Longitud bulbo Ref: 8033 (L): 50 mm. 8035 (L): 100 mm. Escala: Doble escala °C & °F. Precisión: ±2.5%. Rosca 1/2"G.

Bimetallic thermometer 63 mm 8033 (bottom entry L: 50 mm) - 8035 (bottom entry L: 100 mm)

Sheath material: brass. Box dimensions: 63 mm. Material: zinc iron plated. Sight: Glass. Sheath length Ref: 8033 (L): 50 mm. 8035 (L): 100 mm. Double escale °C & °F. Precision: ±2.5%. Thread 1/2"G.

8033 206	-20 +60 °C	1-30	17,51
8033 060	0 +60 °C	1-30	17,51
8033 120	0 +120 °C	1-30	17,51
8035 206	-20 +60 °C	1-50	20,04
8035 060	0 +60 °C	1-24	20,04
8035 120	0 +120 °C	1-24	20,04



Información técnica
Technical information

Ref.8036



Termómetros bimetalicos inoxidables. Conexión posterior

Dimensiones caja: 100 mm. Material: AISI 304.
Aro: AISI 304, bayoneta. Visor: Cristal.
Material bulbo: AISI 304.
Longitud bulbo (L): 100 mm.
Precisión ±1,6%. Doble escala °C & °F. Rosca 1/2" G (deslizante).

Stainless steel bimetallic thermometer. Back connection

Box dimensions: 100 mm. Material: AISI 304.
Ring: AISI 304, bayonet. Sight: Glass. Stem material: AISI 304.
Stem length (L): 100 mm.
Precision ±1,6%. Double scale °C & °F. Thread 1/2" G (sliding).

CÓDIGO CODE	ESCALA SCALE	CAJA / BOX CARTON	P.V.P. € PRICE €
8036 206	-20 +60	1-50	46,13
8036 305	-30 +50	1-50	46,13
8036 404	-40 +40	1-20	46,13
8036 060	0 +60	1-20	46,13
8036 100	0 +100	1-20	46,13
8036 120	0 +120	1-20	46,13
8036 160	0 +160	1-20	46,13
8036 200	0 +200	1-20	46,13
8036 300	0 +300	1-20	46,13



Información técnica
Technical information

Ref.8037



Termómetros bimetalicos inoxidables. Conexión inferior

Dimensiones caja: 100 mm. Material: AISI 304.
Aro: AISI 304, bayoneta. Visor: Cristal. Material bulbo AISI 304.
Diámetro bulbo 8 mm. Longitud bulbo (L): 100 mm.
Precisión ±1,6%. Doble escala °C & °F.
Rosca 1/2" G (deslizante).

Stainless steel bimetallic thermometers. Bottom connection

Box dimensions: 100 mm. Material: AISI 304.
Ring: AISI 304, bayonet. Sight: Glass. Stem material: AISI 304.
Stem length (L): 100 mm.
Precision ±1,6%. Double scale °C & °F.
Thread 1/2" G (sliding).

8037 206	-20 +60	1-30	72,60
8037 305	-30 +50	1-50	72,60
8037 404	-40 +40	1-50	72,60
8037 060	0 +60	1-30	72,60
8037 100	0 +100	1-30	72,60
8037 120	0 +120	1-30	72,60
8037 160	0 +160	1-30	72,60
8037 200	0 +200	1-30	72,60
8037 300	0 +300	1-50	72,60



Información técnica
Technical information

Ref.8039



Termómetros bimetalicos inoxidables. Conexión orientable

Dimensiones caja: 100 mm. Material caja: acero inoxidable.
Precisión: 1.6. Rango de escalas de -40 +60°C a 0-300°C.
Diseño bulbo con rosca. Conexión 1/2". Presión máx. 25 bar.
Visor de cristal.

Stainless steel bimetallic thermometer. Adjustable connection

Box dimensions: 100 mm. Case material: stainless steel.
Accuracy class: 1.6. Scale ranges -40 +60°C to 0-300°C.
Design: stem with thread. Connection: every angle 1/2".
Pressure max: 25 bar. Sight: glass.

8039 206	-20 / +60	1-15	84,50
8039 305	-30 +50	1-10	84,50
8039 404	-40 +40	1-10	84,50
8039 060	0 / +60	1-15	84,50
8039 100	0 / +100	1-15	84,50
8039 120	0 +120	1-15	84,50
8039 160	0 +160	1-15	84,50
8039 200	0 +200	1-15	84,50
8039 300	0 +300	1-15	84,50



Información técnica
Technical information

Ref.8045 - 8046



Termómetro de capilla 1/2" - Longitud 50mm

Salida inferior, vaina latón. Longitud = 50 mm. Rosca G 1/2".

Glass thermometers 1/2" - Length 50mm

Bottom entry, brass sheath. Length = 50 mm. G 1/2" thread.

Termómetro de capilla 1/2" Longitud 100mm

Salida inferior, vaina latón.
Longitud = 100 mm. Rosca G 1/2".

Glass thermometers 1/2" Length 100mm

Bottom entry, brass sheath.
Length = 100 mm. G 1/2" thread.

ref.	G	A	B	C	L
8045 404	1/2"	165	38	10	50
8045 060	1/2"	165	38	10	50
8045 120	1/2"	165	38	10	50
8046 404	1/2"	165	38	10	100
8046 060	1/2"	165	38	10	100
8046 120	1/2"	165	38	10	100

8045 404	-40 +40	1-60	39,24
8045 060	0 +60	1-60	39,24
8045 120	0 +120	1-50	39,24
8046 404	-40 +40	1-50	52,34
8046 060	0 +60	1-60	52,34
8046 120	0 +120	1-60	52,34

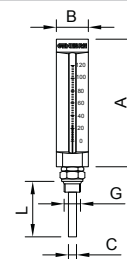

Información técnica
Technical information

CÓDIGO CODE	ESCALA SCALE	CAJA / BOX CARTON	P.V.P. € PRICE €
----------------	-----------------	----------------------	---------------------

Ref. 8045LA - 8046LA



Termómetro de capilla 1/2" - Longitud 50 mm

Salida inferior, vaina latón, caja aluminio anodizado dorado. Longitud = 50 mm. Rosca G 1/2".

Glass Thermometer - Length 50 mm.

Bottom entry, brass sheath, casing aluminum gold anodizing. Length = 50 mm. G 1/2" thread.

Termómetro de capilla 1/2" - Longitud 100 mm

Salida inferior, vaina latón, caja aluminio anodizado dorado. Longitud = 100 mm. Rosca G 1/2".

Glass Thermometer - Length 100 mm.

Bottom entry, brass sheath, casing aluminum gold anodizing. Length = 100 mm. G 1/2" thread.

ref.	G	A	B	C	L
8045LA 060	1/2"	165	38	10	50
8045LA 120	1/2"	165	38	10	50
8046LA 060	1/2"	165	38	10	50
8046LA 120	1/2"	165	38	10	50

8045LA 060	0 +60	1-60	42,29
8045LA 120	0 +120	1-60	42,29

8046LA 060	0 +60	1-60	47,62
8046LA 120	0 +120	1-60	47,62

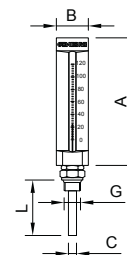

Información técnica
Technical information

Ref. 8047 - 8048



Termómetro de capilla 1/2" Longitud 50mm

Salida angular 90°, vaina latón. Longitud = 50 mm. Rosca G 1/2".

Glass thermometers 1/2" Length 50mm

90° angle entry, brass sheath. Length = 50 mm. G 1/2" thread.

Termómetro de capilla 1/2" Longitud 100mm

Salida angular 90°, vaina latón. Longitud = 100 mm. Rosca G 1/2".

Glass thermometers 1/2" Length 100mm

90° angle entry, brass sheath. Length = 100 mm. G 1/2" thread.

ref.	G	A	B	C	L
8047 404	1/2"	165	38	10	50
8047 060	1/2"	165	38	10	50
8047 120	1/2"	165	38	10	50
8048 404	1/2"	165	38	10	100
8048 060	1/2"	165	38	10	100
8048 120	1/2"	165	38	10	100

8047 404	-40 +40	1-30	41,63
8047 060	0 +60	1-24	41,63
8047 120	0 +120	1-24	41,63

8048 404	-40 +40	1-24	54,70
8048 060	0 +60	1-20	54,70
8048 120	0 +120	1-24	54,70

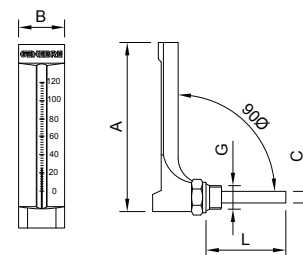

Información técnica
Technical information

Ref. 8047LA



Termómetro de capilla 1/2" - Longitud 50 mm

Salida angular 90°, vaina latón, caja aluminio anodizado dorado. Longitud = 50 mm. Rosca G 1/2".

Glass Thermometer - Length 50 mm.

90° angle entry, brass sheath, casing aluminum gold anodizing. Length = 50 mm. G 1/2" thread.

ref.	G	A	B	C	L
8047LA 060	1/2"	165	38	10	50
8047LA 120	1/2"	165	38	10	50

8047LA 060	0 +60	1-24	45,22
8047LA 120	0 +120	1-24	45,22

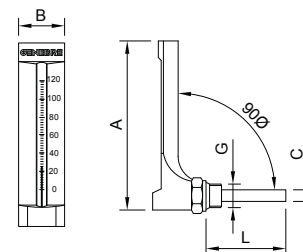

Información técnica
Technical information

Ref.8050



8050 / 8051 / 8052
Sonda PT100 Rosca = 1/2" Diámetro = 6 mm
 Elemento extraíble encamisado.
 Bornes de conexión 3 hilos

8050 / 8051 / 8052
Probe PT100 Thread = 1/2" Diameter = 6 mm
 Element removable.
 3-wire connection terminals

8055 / 8056 / 8057
Sonda PT100 Rosca = 1/2" Diámetro = 6 mm
 Elemento extraíble encamisado.
 Apto para convertidor (8090E)

8055 / 8056 / 8057
Probe PT100 Thread = 1/2" Diameter = 6 mm
 Element removable.
 Suitable for converter (8090E)

8058 / 8059 / 8060
Sonda PT100 Doble R = 1/2" Diámetro = 6 mm
 Elemento extraíble encamisado.
 Cabezal DIN BR roscado. PN 16.

8058 / 8059 / 8060
Probe PT100 Double = 1/2" Diameter = 6 mm
 Element removable.
 2 x 3-wire connection terminals

CÓDIGO CODE	ESCALA SCALE	CAJA / BOX CARTON	P.V.P. € PRICE €
8050 100	100 mm	1-16	91,04
8051 250	300 mm	8	97,33
8052 400	400 mm	6	108,77

8055 100	100 mm	16	81,26
8056 250	300 mm	8	89,24
8057 400	400 mm	6	103,13

8058 100	100 mm	16	120,07
8059 250	300 mm	8	126,30
8060 400	400 mm	6	132,56



Información técnica
 Technical information



Ref.8063



Sonda PT 100
 Diámetro = 6 mm.
 Longitud = 100 mm con cable de silicona y muelle.

Probe PT100
 Diameter = 6 mm.
 Length = 100 mm with silicone and spring wire.

8063 005	3 mm	100	65,12
----------	------	-----	-------



Información técnica
 Technical information

Ref.8090E - 8095E **NEW**



Transmisor de temperatura para cabezal PT100
 Escala y tipo de entrada completamente programable por PC (Pt100).
 Salida 4-20 mA.

PT100 Temperature Head Transmitter
 Scale and outlet type completely programable through PC (Pt100). Output
 4-20mA.

Interfase y software para convertidor 8090E
interface and software for 8090E converter

8090E 00	-	0.028	50-300	86,97
----------	---	-------	--------	-------

8095E 00	-	0.061	1	272,73
----------	---	-------	---	--------



Información técnica
 Technical information

Ref.8069



Indicador entrada programable, con 2 reles alarma
 72x36 mm. J, K, PT100, 4-20mA.

Indicator with a programated entry, with 2 alarm relays
 72x36 mm. J, K, PT100, 4-20mA.

CÓDIGO CODE	ESCALA SCALE	CAJA / BOX CARTON	P.V.P. € PRICE €
8069 00	-	1-72	66,67



Información técnica
 Technical information

Ref.8070



Indicador entrada programable, con 2 releas alarma

48 x 96 mm. Input universal.
Tensión de alimentación 100-240V.
Retransmisión de señal de entrada a 20-4mA.

Indicator with a programated entry, with 2 alarm relays

48 x 96 mm. Universal input.
100 and 240V power supply.
Input signal transmitter 20-4mA.

CÓDIGO CODE	ESCALA SCALE	CAJA / BOX CARTON	P.V.P. € PRICE €
----------------	-----------------	----------------------	---------------------

8070 00	-	1	140,29
---------	---	---	--------



Información técnica
Technical information

Ref.8071



Regulador inp. programable out relé + 1 alarmas

Regulator inp. programate out relay + 2 alarms

CÓDIGO CODE	MEDIDA SIZE	PESO WEIGHT	CAJA / BOX CARTON	P.V.P. € PRICE €
----------------	----------------	----------------	----------------------	---------------------

8071 C24V	-	0,234	1	143,19
-----------	---	-------	---	--------



Información técnica
Technical information

Ref.8080



Transmisor de presión inox.

Rosca 1/2".
Salida: 4-20mA.
Alimentación: 12-36 VDC.
Precisión: 0,5%fs.
Conexión eléctrica: DIN 43650A (electroval. 4 polos).
Protección: IP65.
Libre de aceite.

Stainless steel pressure transmitters

Thread 1/2".
Out: 4-20mA.
Supply: 12-36 VDC.
Precision: 0,5%fs.
Electric connection: DIN 43650A (solenoid 4 poles).
Protection: IP65.
Free of oil.

CÓDIGO CODE	ESCALA SCALE	CAJA / BOX CARTON	P.V.P. € PRICE €
----------------	-----------------	----------------------	---------------------

8080 005	0 +5 bar	1-10	187,76
8080 010	0 +10 bar	1-10	187,76
8080 016	0 +16 bar	1-10	187,76
8080 025	0 +25 bar	1-10	187,76
8080 050	0 +50 bar	1-10	187,76
8080 100	0 +100 bar	1-10	187,76
8080 250	0 +250 bar	1-10	187,76
8080 500	0 +500 bar	1-10	187,76



Información técnica
Technical information

Ref.8081



Transmisor de presión inox. mini

Rosca 1/2" G/M.
Salida: 4-20 mA (2 hilos).
Alimentación: 12 - 28VDC.
Conexión eléctrica: conector tipo Hirschman mini.
Protección: IP65.
Precisión: 0,5%fs.
Libre de aceite.

Stainless steel pressure transmitters

Thread 1/2" G/M.
Out: 4-20 mA (2 thread).
Supply: 12 - 28VDC.
Electric connection: Type Hirschman mini connector.
Protection: IP65.
Precision: 0,5%fs.
Free of oil.

CÓDIGO CODE	ESCALA SCALE	CAJA / BOX CARTON	P.V.P. € PRICE €
----------------	-----------------	----------------------	---------------------

8081 005	0 +5 bar	1-100	102,09
8081 007	0 +7 bar	1-100	102,09
8081 010	0 +10 bar	1-100	102,09
8081 016	0 +16 bar	1-100	102,09
8081 025	0 +25 bar	1-100	102,09
8081 050	0 +50 bar	1-10	102,09
8081 100	0 +100 bar	1-10	102,09
8081 250	0 +250 bar	1-10	102,09
8081 400	0 +400 bar	1-10	102,09
8081 500	0 +500 bar	1-10	102,09



Información técnica
Technical information

Ref.8081E



Transmisor de presión inox. mini

Rosca 1/4" G/M.
Salida: 4-20 mA (2 hilos).
Alimentación: 12 - 28VDC.
Conexión eléctrica: conector tipo Hirschman mini.
Protección: IP65.
Precisión: 0,5%fs.
Libre de aceite.

Stainless steel pressure transmitters

Thread 1/4" G/M.
Out: 4-20 mA (2 thread).
Supply: 12 - 28VDC.
Electric connection: Type Hirschman mini connector.
Protection: IP65.
Precision: 0.5%fs.
Free of oil.

CÓDIGO CODE	ESCALA SCALE	CAJA / BOX CARTON	P.V.P. € PRICE €
8081E 025	0 +25 bar	1-100	92,62
8081E 250	0 +250 bar	1-10	92,62



Información técnica
Technical information

Ref.8180



Transmisor de presión inox.

Rosca 1/2".
Salida: 4-20mA.
Alimentación:10-30 VDC.
Precisión: 0,5%fs.
Conexión eléctrica: DIN 43650A (electroval.4 polos).
Protección: IP65.
Libre de aceite.
ATEX: Ex i a II CT6.

Stainless steel pressure transmitters

Thread 1/2".
Out: 4-20mA.
Supply: 10-30 VDC.
Precision: 0,5%fs.
Electric connection: DIN 43650A (solenoid 4 poles).
Protection: IP65.
Free of oil.
ATEX: Ex i a II CT6.

8180 010	0 +10 bar	1-50	291,78
8180 025	0 +25 bar	1-1	333,64
8180 060	0 +60 bar	1-1	333,64
8180 101	-1 +1 bar	1-1	459,31
8180 100	0 +100 bar	1-1	333,64
8180 250	0 +250 bar	1-1	333,64



Información técnica
Technical information

Ref.8085L



Transmisor de nivel hidrostático

Transmisor de nivel hidrostático 0,6 bar con 10, 20 o 30 metros cable.

Hydrostatic level transmitter

Hydrostatic level transmitter 0.6 bar with 10, 20 or 30 wire meters.

8085L 001	10m	1-1	447,60
8085L 002	20m	8	494,71
8085L 003	30m	1-4	541,84



Información técnica
Technical information

RECAMBIOS

SPARE PARTS

Recambios para válvulas de esfera

Spare parts for ball valves

REF. VÁLVULA VALVE REF.	ASIENTOS SEATS PTFE	ASIENTOS SEATS PTFE+FV	ASIENTOS/SEATS PTFE+GRAFITO PTFE + GRAPHITE	ASIENTOS/SEATS PTFE+I- NOXIDABLE PTFE + STAINLESS STEEL	ESFERA BALL	EJE STEM
2015	2822Txx	2822xx	2822Cxx		2907xx	2905xx
2025-26-27	2820Txx	2820xx	2820Cxx	2820lxx	2907xx 4" = 2904 12	2905xx
2034		2838xx	2838Cxx			
2040-2041		2819xx	2819Cxx		"L": 2840xx "T": 2841xx	
2052-2053	2820Txx	2820xx	2820Cxx	2820lxx	2907xx 4" = 2904 12	2905xx
2105		2925xx			2809xx	I2110xx
2110		2925xx			2807xx	I2110xx
2115		2925xx			2809xx	I2110xx
2118		2818xx	2818Cxx			
2119		2818xx	2818Cxx			
2525		2825xx	2825Cxx			
2526A		2909xx	2909Cxx		2907xx	2908xx
2528		2909xx	2909Cxx		2907xx	2908xx
2528A		2909xx	2909Cxx		2907xx	2908xx
2529		2909xx	2909Cxx		2907xx	2908xx
2540-2541		2928xx	2928Cxx		B2540xx B2541xx	
2933	2912xx					

Nota: XX reemplazar por atributo de medida./ Note: XX replace with size attribute

Elastómetros para válvulas mariposa

Seat for butterfly valves

REF. VÁLVULA VALVE REF.	MATERIAL EPDM	MATERIAL NBR	MATERIAL VITON	MATERIAL PTFE
2101				ET2101xx
2103	E2109xx	EB2109xx	EV2109xx	
2104				ET2104xx
2108	E2109xx	EB2109xx	EV2109xx	
2108A	E2109xx	EB2109xx	EV2109xx	
2109	E2109xx	EB2109xx	EV2109xx	

Nota: XX reemplazar por atributo de medida./ Note: XX replace with size attribute

Recambios para válvulas neumáticas

Spare parts for pneumatic valves

REF. VÁLVULA VALVE REF.	DESCRIPCIÓN DE RECAMBIO	SPARE PARTS DESCRIPTION	CÓD. RECAMBIO SPARE CODE
5060	Empaquetadura eje	Stem packing	E5060xx
5060	Asiento, Junta, Sello pistón, o'ring	Seat, gasket, piston	R5060xx
5060	Protector indicador PVC	Indicator protector ring	C5060xx
5065	Asiento y Junta cuerpo	Seat and gasket o'ring	A5065xx
5065	Empaquetaduras eje y Junta cuerpo	Stem packing, gasket	E5065xx
5065	Obturador, junta asiento, junta cuerpo	Plug, seat ring, gasket	K5065xx
5065A	Asiento y Junta cuerpo	Seat, gasket	A5065Axx
5065A	Empaquetaduras eje y Junta cuerpo	Stem packing, gasket	E5065Axx
5065A	Obturador, junta asiento, junta cuerpo	Plug, seat ring, gasket	K5065Axx
5065- 5065A	Diafragma para actuador 210 cm ³	Diaphragm 210 cm ³	D5065 210
5065- 5065A	Diafragma para actuador 320 cm ³	Diaphragm 320 cm ³	D5065 320

Nota: XX reemplazar por atributo de medida./ Note: XX replace with size attribute

Recambios para otras válvulas y accesorios

Spare parts for another valves and accessories

REF. VÁLVULA VALVE REF.	DESCRIPCIÓN DE RECAMBIO	SPARE PARTS DESCRIPTION	CÓD. RECAMBIO SPARE CODE
2228	Kit tomas de presión	Test point kit	T2228
2228	Volante	Hand wheel	V2228xx
2231	Eje-Fuelle-Junta-Empaque-Espina	Stem-bellows-gasket	K2231xx
2240 / 2250	Cristal Templado Soda-Cálcico (estándar)	Tempered soda lime glass packing-pin	C2250xx
2240 / 2250	Cristal Borosilicato	Borosilicate glass	C2250Pxx
2240 / 2250	Junta PTFE	PTFE gasket	J2250xx
2282	Disco	Disc	K2282xx
2284	Disco	Disc	K2284xx
2401 / 2402	Kit de Muelles c/arandelas PTFE	Spring kit w/PTFE rings	K2401xx
2406	Kit de Juntas y asiento	O'ring kit	K2406xx
2415	Muelle	Spring	K2415xx
2448	Asiento y Junta	Seat and gasket	K2448xx
2453	Esfera y junta o'ring	Ball and gasket	K2453
2458G	Junta	Gasket	J2458Gxx
2458G	Tamiz	Screen	T2458Gxx
2460	Tamiz y Junta PTFE	Screen and gasket	2991xx
2461	Tamiz	Screen	2861xx
2461	Junta PTFE	Gasket	J2461xx
2856	Asiento de Silicona	Silicone seat	JS2856xx

Nota: XX reemplazar por atributo de medida./ Note: XX replace with size attribute

Recambios para otras válvulas y accesorios línea sanitaria

Spare parts for another valves and accessories sanitary line

REF. VÁLVULA VALVE REF.	DESCRIPCIÓN DE RECAMBIO	SPARE PARTS DESCRIPTION	CÓD. RECAMBIO SPARE CODE
2921	Asiento y o'ring	Seat and o'ring	K2947 04
2922	Asientos y o'rings	Seats and o'rings	K2922 04
2932	Asientos y juntas	Seats and o'rings	R2932xx
2934	Asiento - Junta y Muelle	Seat, gasket, spring	K2934xx
2935	Asiento - Junta y Muelle	Seat, gasket, spring	K2934xx ó K2935xx
2936	Asiento - Junta y Muelle	Seat, gasket, spring	K2934xx ó K2935xx
2940	Elastómero EPDM	EPDM seat	E2940xx
2940	Elastómero Vitón (FKM)	FKM seat	EV2940xx
2941/42/43E	Elastómero EPDM	EPDM seat	E2941xx
2941/42/43E	Elastómero NBR	NBR seat	EB2941xx
2941/42/43E	Elastómero Silicona	Silicone seat	ES2941xx
2941/42/43E	Elastómero Vitón (FKM)	FKM seat	EV2941xx
2941/42/43E	Disco obturador	Disc	D2941Exx
2945 - 2946	Membrana Silicona (Std)	Silicone diaphragm (Std)	D2945xx
2945 - 2946	Membrana EPDM	EDM diaphragm	E2945xx
2947	Asiento y o'ring	Seat, o'ring	K2947 04
2950	Asientos y o'rings	Seat, o'rings	K2922 04
2951	Asientos y o'rings	Seat, o'rings	K2951
5944 - 5949	Cupula PVC	PVC cover	C5944

Nota: XX reemplazar por atributo de medida./ Note: XX replace with size attribute

Recambios para actuadores neumáticos

Spare parts for pneumatic actuator

DESCRIPCIÓN DE RECAMBIO SPARE PARTS DESCRIPTION	ACTUADOR GEN-AIR	ACTUADOR GNP
Kit de Reparación / Repair Kit	KGNxx	KGNPxxxx
Muelles / Spring Cartridge	C5800xx	C5800xxxx
Pistones / Pistons	EMB	EMBxxxx
Tapa derecha / Right End Cap	TGNxxD	
Tapa izquierda / Left End Cap	TGNxxI	

Nota: XX y XXXX reemplazar por atributo de medida.
Note: XX and XXXX replace with size attribute

Recambios para electroválvulas 5/2

Spare parts for solenoid valve 5/2

REFERENCIA REFERENCE	DESCRIPCIÓN DE RECAMBIO SPARE PARTS DESCRIPTION	CÓD. RECAMBIO SPARE CODE
4519	Bobina / Coil	4819xxxx
4521	Bobina / Coil	4821 C24V
4522	Bobina / Coil	4822xxxx
4523	Bobina / Coil	4819xxxx
4519 / 4523	Conector / Connector	4801 05

Nota: XXXX reemplazar por atributo de medida.
.Note: XXXX replace with size attribute

Recambios para posicionadores neumáticos y electropneumáticos

Spare parts for pneumatic and electropneumatic positioners

REFERENCIA REFERENCE	DESCRIPCIÓN DE RECAMBIO SPARE PARTS DESCRIPTION	CÓD. RECAMBIO SPARE CODE
5950/51/52	Válvula Piloto / Pilot valve	4819xxxx

Recambios para cajas finales de carrera

Spare parts for limit switch box

REF. VÁLVULA VALVE REF.	DESCRIPCIÓN DE RECAMBIO	SPARE PARTS DESCRIPTION	CÓD. RECAMBIO SPARE CODE
5987 02/04/06/08/10/12	Cúpula transparente PVC	Indicator cover	C5987
5987 02/04/06/08/10/12	Indicador Posición PVC	Indicator	CI5987
5987 02	Microrruptor	Micro switch	S5987 02
5987 04	Sensor Inductivo	Inductive sensor	S5987 04
5987 06	Sensor Inductivo	Inductive sensor	S5987 06
5987 08	Sensor Inductivo	Inductive sensor	S5987 08
5987 10	Sensor Inductivo	Inductive sensor	S5987 10
5987 12	Sensor Inductivo	Inductive sensor	S5987 08

Recambios para actuadores eléctricos monofásicos

Spare parts for single phase electric actuator

REFERENCIA REFERENCE	MODELO ACTUADOR ACTUATOR MODEL	FUENTE DE ALIMENTACIÓN POWER SUPPLY	PLACA BASE ELECTRONIC BOARD
5803 47/48/51/52	J3CS	F5803S 51	P5803S 51
5803 47/48/51/52	J4CS	F5803S 51	P5803S 47
5803 53/54	J3C	F5803HC 53	P5803C 53
5803L 53/54	J3C	F5803LC 53	P5803C 53
5803 53/54	J4CS	F5803S 53	P5803S 47

GENEBRE
PARTNER IN FLUID CONTROL SOLUTIONS

Índice por artículo

Article index

Nº Artículo Article N°	Nº Página Page N°	Nº Artículo Article N°	Nº Página Page N°	Nº Artículo Article N°	Nº Página Page N°	Nº Artículo Article N°	Nº Página Page N°
0090	140	0440	146	2041	26	2226	39
0090N	140	0450	146	2041N	26	2226N	39
0092	140	0460	146	2048	26	2227	39
0092N	140	0470	146	2052	27	2227N	39
0120	140	0480	146	2053	27	2228	40
0120N	140	2001	21	2094	35	2229A	41
0130	140	2002	21	2100	35	2230	40
0130N	140	2004	21	2100D	35	2230N	40
0149	141	2005	21	2101	29	2231	41
0150	141	2006	21	2101T	30	2232A	42
0180	141	2007	22	2102	28	2232N	42
0180N	141	2007N	22	2103	32	2232S	42
0240	141	2008	22	2104	29	2233A	43
0240N	141	2009	22	2105	36	2233N	42
0241	142	2010	22	2108	30	2233S	42
0241N	142	2011	23	2108A	31	2234N	43
0245	142	2013	23	2108AB	32	2234S	43
0270	142	2014	23	2108B	31	2240	43
0270N	142	2014N	23	2109	33	2250	44
0280	142	2015	23	2109B	33	2252	44
0280N	142	2015N	23	2110	36	2252N	44
0285	143	2015V	68	2113	34	2253	44
0290	143	2016	24	2114	34	2253N	44
0290N	143	2025	24	2114D	34	2256	45
0300	143	2025C	24	2115	36	2257	45
0300N	143	2025N	24	2118	37	2258	45
0312	143	2025V	68	2119	37	2258N	45
0340	144	2026	25	2120	34	2259	46
0340N	144	2026V	68	2120D	34	2272	46
0341	144	2027	25	2220	38	2272N	46
0341N	144	2027V	68	2220N	38	2274	46
0399	144	2034	25	2221	38	2274N	46
0399N	144	2034N	25	2222	38	2275	47
0400	145	2034S	26	2223	38	2281	47
0410	145	2035	28	2224	38	2281N	47
0420	145	2040	26	2225	39	2282	48
0430	145	2040N	26	2225N	39	2282N	48

Nº Artículo Article N°	Nº Página Page N°	Nº Artículo Article N°	Nº Página Page N°	Nº Artículo Article N°	Nº Página Page N°	Nº Artículo Article N°	Nº Página Page N°
2284	48	2447N	55	2835AE	66	2981	81
2284N	48	2448	56	2835E	65	2982	81
2285	49	2449	56	2848	66	2983	81
2285N	49	2450	56	2850	66	2984	81
2286	49	2451	57	2852	67	2985	82
2286A	50	2453	57	2856	67	2986	82
2287	50	2455	57	2856A	67	2987	82
2287A	50	2458G	58	2856N	67	2988	82
2288	51	2459	58	2918	74	3073	40
2288N	51	2459A	58	2919	74	3886	66
2289	51	2460	59	2921	74	3887	67
2289N	51	2460N	59	2922	74	4519	114
2292	47	2461	60	2932	75	4521	114
2293	47	2461A	60	2933	76	4522	114
2294	48	2462	59	2934	76	4523	114
2294N	48	2463	59	2935	76	4800	115
2295	49	2463N	59	2936	76	4801	115
2295N	49	2525	60	2940	77	4819	114
2296N	51	2526A	61	2941E	77	4821	115
2297A	52	2526AV	68	2941EB	77	4822	115
2401	52	2528	61	2942E	78	5013	84
2402	52	2528A	62	2942EB	78	5015	94
2403E	35	2528AC	62	2943E	78	5025	95
2406	53	2528AV	69	2943EB	78	5026	95
2413	53	2528C	61	2944	89	5027	95
2413N	53	2528V	69	2945	79	5029	96
2415	53	2529	62	2946	79	5032	85
2416	54	2540E	63	2946E	79	5040	97
2416N	54	2541E	63	2947	75	5041	97
2417	54	2544	63	2949	89	5052	98
2430	54	2545	63	2950	75	5053	98
2430N	54	2830	63	2951	75	5060	93
2440	54	2830N	63	2952	79	5060N	93
2442	55	2831	64	2954	80	5062	93
2445	55	2831A	64	2955	80	5062N	93
2445N	55	2833	65	2956	80	5065	93
2447	55	2834	65	2957	80	5065A	94

N° Artículo Article N°	N° Página Page N°	N° Artículo Article N°	N° Página Page N°	N° Artículo Article N°	N° Página Page N°	N° Artículo Article N°	N° Página Page N°
5070	96	5540E	99	5682E	125	8028	155
5080	96	5541E	99	5919	131	8029	155
5101	29	5544	100	5940	83	8032	155
5101T	30	5545	100	5940	85	8033	155
5103	32	5605	130	5941E	86	8034	155
5104	29	5608	135	5941E	83	8035	155
5105	106	5608A	135	5942E	83	8036	156
5108	30	5611	133	5942E	86	8037	156
5108A	31	5611T	133	5943E	87	8039	156
5108AB	32	5613	87	5943E	84	8045	156
5108B	31	5615	130	5944	89	8045LA	157
5109	33	5618	131	5949	89	8046	156
5109B	33	5621	124	5950	116	8046LA	157
5111	108	5625	127	5951	116	8047	157
5111T	108	5626A	127	5952	116	8047LA	157
5113	109	5628	128	5953	117	8048	157
5114	111	5628A	129	5971	117	8050	158
5115	106	5629	129	5975	117	8063	158
5118	107	5632	87	5976	117	8069	158
5119	110	5633	131	5977	117	8070	159
5309	120	5634	134	5977A	117	8071	159
5315	119	5635	124	5977B	117	8080	159
5325	119	5636	124	5978	117	8081	159
5328	119	5637	124	5978A	117	8081E	160
5330	70	5639	132	5981	120	8085L	160
5332	70	5640	125	5982	120	8090E	158
5334	121	5641	125	5983	120	8095E	158
5334	137	5642E	126	5984	117	8180	160
5508	112	5643E	126	5985	118	8401	147
5508A	113	5644	126	5987	118	8401D	147
5519	107	5645	126	5987 20	118	8402	147
5525	101	5649	124	5988	121	8402D	147
5526A	102	5650	88	5989	120	8403	148
5528	103	5651E	88	8011	154	8403D	148
5528	103	5652E	88	8012	154	8404	148
5528A	104	5653E	89	8020	154	8404D	148
5529	105	5672E	125	8021	154	8404N	148

N° Artículo Article N°	N° Página Page N°	N° Artículo Article N°	N° Página Page N°	N° Artículo Article N°	N° Página Page N°	N° Artículo Article N°	N° Página Page N°
8404ND	149						
8405	149						
8405D	149						
8405N	149						
8405ND	149						
8406	150						
8406D	150						
8406N	150						
8406ND	150						
D2102	28						
P5953	117						

Condiciones generales de venta

General sales conditions

PRECIOS: Los precios se entienden en nuestro almacén, siendo los portes, el I.V.A. y acarreo a cargo del comprador, salvo acuerdo previo.

CONDICIONES DE PAGO: En aplicación de la Ley 15/2010 que limita los plazos máximos de pago en las operaciones comerciales, hemos ajustado las condiciones a lo dispuesto en la misma. En caso de diferirse el pago, los gastos de negociación de efectos y/o los intereses legales especificados serán a cargo del comprador. El impago de cualquier efecto o recibo, conllevará la inmediata suspensión de suministros y servicios.

PEDIDOS: Para la tramitación de cualquier suministro será indispensable que el comprador nos remita el pedido por escrito indicando claramente la referencia Genebre, incluidos los dígitos de la medida y también la cantidad deseada respetando las unidades de compra mínima (por caja), tal como especifica Genebre en su catálogo. El importe mínimo del pedido se establece en 50€ para pedidos del Mercado Nacional y de 100€ para pedidos comunitarios. Si existen condicionantes no previstos, Genebre S.A. se reserva el derecho de aceptación o anulación de los pedidos cursados. Cada pedido solicitado a Genebre S.A. genera una expedición para el cliente con su coste de transporte correspondiente; por lo que recomendamos preparen sus pedidos completos una vez al día para optimizar el transporte. Todos los pedidos serán confirmados por Genebre, S.A. vía email/fax. Salvo notificación de lo contrario en las siguientes 2 horas (mercado nacional), el pedido confirmado seguirá su curso sin derecho a posteriores reclamaciones.

TARIFAS DE PRECIOS: Genebre S.A. comunicará a sus clientes cualquier cambio que se produzca en las tarifas del catálogo a través de alguna de las vías de comunicación usuales (web, email, correo).

CANCELACIÓN DE PRODUCTOS DE CATÁLOGO: Genebre, S.A. comunicará a sus clientes cualquier cancelación de productos del catálogo.

ESPECIFICACIONES TÉCNICAS: El catálogo de Genebre, S.A. contiene los requisitos técnicos y normas aplicables a los productos suministrados. Genebre S.A. se reserva la facultad de cambiar en todo o en parte el diseño y materiales de cualquiera de sus productos, debido a la mejora continua de nuestros productos.

EXPEDICIONES Y PORTES: Los pedidos enviados a la Península, Baleares y Andorra que superen los 500 € (impuestos no incluidos) se suministrarán a portes pagados. Para los envíos con destino Canarias, Ceuta y Melilla, el importe mínimo del pedido para la aplicación de esta condición será de 1000 €. En cualquier caso, las mercancías viajan siempre por cuenta y riesgo del comprador, aun en los casos de convenios especiales.

ENTREGA: Los pedidos se suministrarán siempre por cajas completas, según especificaciones de catálogo.

RECLAMACIONES: Las eventuales reclamaciones deberán formularse dentro de los 15 días siguientes al de recepción de la mercancía por el comprador, rechazándose las efectuadas después de dicho plazo límite. NO se aceptará ninguna devolución de material sin aprobación previa de nuestro Departamento Comercial que facilitará un número de boletín de devolución que debe acompañar al material devuelto. Todas las devoluciones serán con los portes a cargo del comprador. Y se realizará un cargo por demérito del 10% del valor de la mercancía para todos los materiales, excepto para las válvulas automatizadas que será del 30%.

GARANTÍA: Queda limitada al reemplazo de las piezas reconocidas como defectuosas de fabricación por el Departamento de Calidad de Genebre S.A.. No admitiremos ninguna reclamación transcurridos 15 días de la recepción de la mercancía por el comprador.

PROPIEDAD DE LA MERCANCÍA: Genebre, S.A. se reserva el derecho de propiedad de la mercancía suministrada, hasta que el comprador no haya satisfecho totalmente el importe de la misma. En el intervalo, se considerará en concepto de depósito y custodia. La mercancía podrá ser retirada por incumplimiento de pago en el plazo previamente estipulado.

LITIGIOS: En caso de litigio, ambas partes aceptan someter sus diferencias a los Juzgados de L'Hospitalet de Llobregat.

PRICES: Prices are considered to be EX WORKS, being the freight and transportation at the cost of the purchaser, unless previous agreement has been reached.

PAYMENT TERMS: In accordance to Law 15/2010, payment terms shall be limited to 60 days. In the event that payment is deferred, all expenses and interests occurred will be paid by the Purchaser. Failure to honour any payment when dues shall entitle the Seller to so suspend supplies and services with immediate effect.

ORDERS: Regarding the handling of any supply, it is compulsory for the purchaser to send a written signed and sealed purchasing order indicating clearly Genebre's reference, including measures digits, and also the quantity required subject to obligated minimum units of purchase (boxes), as Genebre's Catalogue specifies. The minimum order amount is set at 50€ for National Market orders and 100€ for EU orders. In case of unexpected discrepancies, Genebre has the right to accept or cancel the pending orders. Each order required to Genebre, S.A., opens a client expedition with corresponding transports cost, because of that, we recommend to prepare complete orders once a day to improve the transport. All the orders will be confirmed by Genebre by e-mail/fax. Each confirmed order will be handled without any right from the purchaser to modify it, unless previous notification before 2 hours (national market) after confirmation.

PRICE LIST: Genebre will inform the customers about any change in the price list, using the usual communication channels (web, e-mail or post).

PRODUCTS WITHDRAWAL FROM CATALOGUE: Genebre S.A. will inform the customers about any product withdrawal from the catalogue.

TECHNICAL SPECIFICATIONS: Genebre's catalogue holds all the technical requirements and applicable norms about the products.

SHIPMENT: Goods are shipped under the purchaser's own risk, even in special cases.

DELIVERY: Orders will always be shipped according to full boxes, as specified in the catalogue.

CLAIMS: Eventual claims must be done within 15 days after date of reception of the goods by the purchaser. Claims after such period will not be considered. NO returns will be accepted without the previous approval from our Sales Department, who will issue a return certificate that must be enclosed to the returning goods. All returns freight will be paid by the purchaser. Additionally, a restocking charge of 10% of the products' value will apply, except for the automatic valves that a restocking charge of 30% will apply.

GUARANTEE: It is limited to defective pieces replacement identified by Genebre's Quality Department. We will not accept any return after 15 days from the date of reception by the purchaser.

PROPERTY OF THE GOODS: Genebre has the property right of the supplied goods, until the purchaser has totally paid its value. In the meantime, it will be considered as deposit and custody. Goods shall be claimed in case of breach of payment terms.

DISPUTES: In case of disputes, both parties agree to solve discrepancies in the Barcelona Court of Justice.

GENEBRE
PARTNER IN FLUID CONTROL SOLUTIONS

GENEBRE

PARTNER IN FLUID CONTROL SOLUTIONS

GENEBRE GROUP

Edificio Genebre • Avda. Joan Carles I 46-48 08908 L'Hospitalet de Llobregat (Barcelona) ESPAÑA

www.genebre.es